

# VW Spot-Weldable Strain Gauge

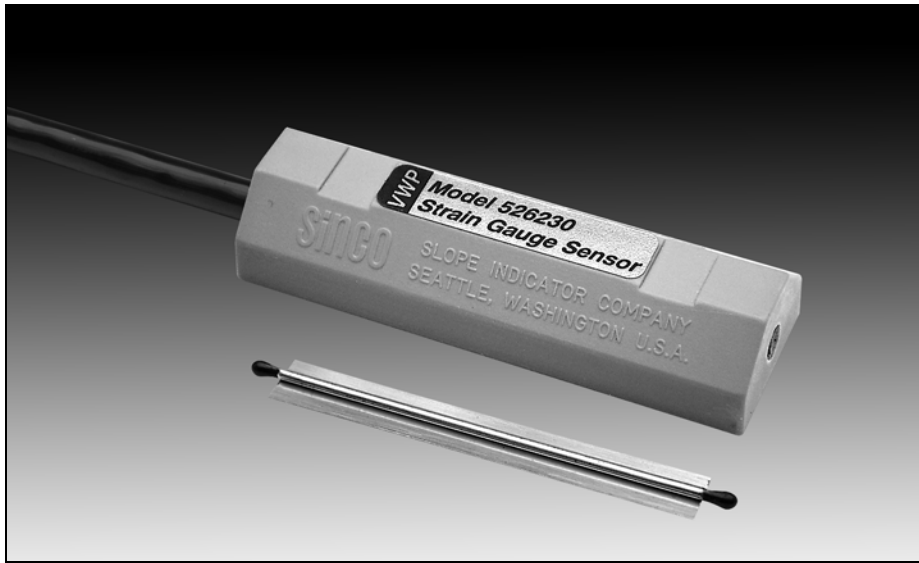

## Advantages

**Preset Gauges:** The spot-weldable is available in three tension ranges to match virtually any application. This eliminates the time-consuming process of tensioning the vibrating wire element in the field.

**Full-Length Welding Flange:** The full length welding flange allows reliable coupling of the gauge to the structural member and prevents misalignment of the end points of the gauge, a common problem with other strain gauges.

**Very Low Profile:** The vibrating wire element is positioned only 0.96 mm (0.038") above the measured member. This patented, low-profile design reduces errors caused by bending of the structural member.

**Stainless Steel Construction:** The outer components of the strain gauge are constructed from stainless steel for corrosion resistance. The wire itself is steel, selected to match the thermal characteristics of structural steel.

## Applications

Spot-weldable vibrating wire strain gauges are used with strain gauge sensors to measure strain in steel. Typical applications include:

- Monitoring structural members of buildings and bridges during and after construction.
- Monitoring changes in load on ground anchors and other post-tensioned support systems.
- Measuring strain in tunnel linings and supports.
- Monitoring areas of concentrated stress in pipelines.
- Monitoring distribution of load in pile tests.

## Operation

The strain gauge operates on the principle that a tensioned wire, when plucked, vibrates at a frequency that is proportional to the strain in the wire.

The gauge is constructed so that a wire is held in tension inside a small diameter, thin-walled tube that welded to the structural member. Loading of the structural member changes the length of the tube and results in a change in the tension of the wire.

An electromagnet in the strain gauge sensor is used to pluck the wire and measure the frequency of vibration. Strain is then calculated by applying calibration factors to the frequency measurement.

## Installation

Rust is removed with a sander and a flat surface is created with a grinder. When the surface is clean, the gauge is welded onto it using a spot welder.

Corrosion protection is applied to the gauge, and then the strain gauge sensor is placed on top of the sensor. After test readings, the sensor is fixed to the gauge either by weldable steel straps or by tie-wraps. The gauge and sensor are then wrapped with mastic and tape.



Spot-weldable strain gauge installed on reinforcing bar. The gauge is later waterproofed with mastic and tape.

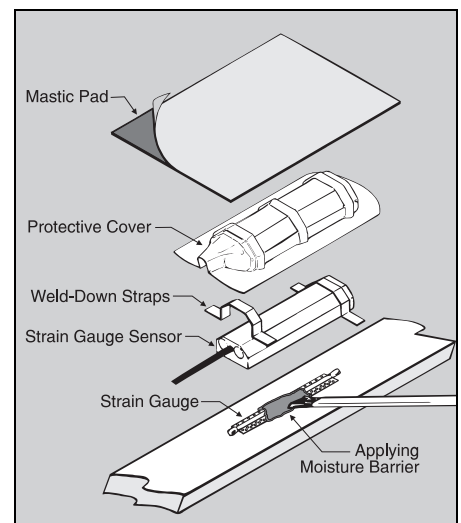

Installation of strain gauge and sensor on flat surface. Protective cover and mastic pad are optional.

**SPOT-WELDABLE STRAIN GAUGE**

**Gauge Set Midrange** . . . . . 52602100  
**Gauge for Compressive Strain** . . . 52602101  
**Gauge for Tensile Strain** . . . . . 52602102

Vibrating wire strain gauge for spot welding to steel. Requires strain gauge sensor below.

**Range:** Approximately 2,500 microstrain.

**Gauge Length:** 62 mm (2.45").

**Height of Wire:** 0.96 mm (0.038") above measured member.

**Thermal Coefficient:**  $10.8 \times 10^{-6}$  per °C,  $6 \times 10^{-6}$  per °F.

**Materials:** Stainless steel flange and tube, steel wire.

**Dimensions:** 66.7 x 7.6 x 1.8 mm, (2.65 x 0.3 x 0.07 inch).

**VW STRAIN GAUGE SENSOR**

**Strain Gauge Sensor** . . . . . 52623000

VW strain gauge sensor is a pluck-type vibrating wire sensor for spot-weldable strain gauge. Includes a thermistor or RTD for temperature measurements and two stainless steel weld-down straps for fixing sensor to structure. Does not include signal cable.

**Frequency Range:** 0.8 to 2.4 kHz.

**Temp Rating:** -29 to 105 °C, -20 to 220 °F.

**Waterproof Rating:** 10.4 bar, 150psi.

**Materials:** Resin-filled ABS plastic case.

**Dimensions:** 80 x 26 x 16 mm, 1 x 3.17 x 0.64".

**Weight:** 28 g (1 oz).

**SIGNAL CABLE**

**Signal Cable** . . . . . 50613524

Shielded cable with four 22-gauge tinned-copper conductors and polyurethane jacket that is rated for 80 °C (176 °F). Attached to sensor at the factory.

**Universal Connector** . . . . . 57705001

**Universal Terminal Box** . . . . . 57711600

Provides connections for 12 sensors and an indicator. Sensors selected by rotary switch. Weatherproof fiberglass box measures 290 mm wide x 345 mm high x 135 mm deep (11.5 x 13.5 x 5.25").

**INSTALLATION ACCESSORIES**

**Scotchkote** . . . . . 06700019

For applying moisture barrier. 440 ml (15oz) can.

**Spare Weld-Down Straps** . . . . . 52623110

Two weldable stainless steel straps designed to hold sensor onto structure.

**Protective Cover** . . . . . 52623120

Formed stainless steel cover for sensor.

**3M Mastic Pad** . . . . . 06700180

Self-vulcanizing sealing material.

**Spot Welder, 115VAC** . . . . . 52602550

Includes tip, hand piece, welding unit, battery, and case.

**Spot Welder, 220VAC** . . . . . 52602560

Includes tip, hand piece, welding unit, battery, and case.

**READOUTS**

Compatible readouts include the VW Data Recorder and other pluck-type VW readouts. See separate data sheets for features and specifications.

**DATA LOGGERS**

Compatible data loggers include the Campbell Scientific CR10X with VW interface and an AM16/32 multiplexer. Multiplexer can accommodate 16 strain gauge sensors with temperature readings or 32 sensors without temperature readings. See separate data sheet.