

Vented VW Settlement Cell

52612199

Copyright ©2004 Slope Indicator Company. All Rights Reserved.

This equipment should be installed, maintained, and operated by technically qualified personnel. Any errors or omissions in data, or the interpretation of data, are not the responsibility of Slope Indicator Company. The information herein is subject to change without notification.

This document contains information that is proprietary to Slope Indicator company and is subject to return upon request. It is transmitted for the sole purpose of aiding the transaction of business between Slope Indicator Company and the recipient. All information, data, designs, and drawings contained herein are proprietary to and the property of Slope Indicator Company, and may not be reproduced or copied in any form, by photocopy or any other means, including disclosure to outside parties, directly or indirectly, without permission in writing from Slope Indicator Company.

SLOPE INDICATOR

12123 Harbour Reach Drive
Mukilteo, Washington, USA, 98275
Tel: 425-493-6200 Fax: 425-493-6250
E-mail: solutions@slope.com
Website: www.slopeindicator.com

Contents

Introduction.....	1
Installation	2
Taking Readings	5
Data Reduction	7
Acceptance Test	9
Diagnostics.....	10
Splicing Vented Signal Cable	11
Terminating Vented Signal Cable ..	12
Constant Level Reservoir	13

Introduction

Introduction The VW settlement cell is designed to measure settlements in construction areas which are inaccessible to standard optical survey techniques. It is especially useful in measuring large changes in settlement under earth dams, landfills, and soft soils.

Theory of Operation A settlement cell is a device used to monitor settlements in embankments, fills, and foundation soil. It provides a single point measurement of settlement or heave.

The settlement cell consists of three main components: a liquid filled tube, a pressure transducer, and a reservoir of liquid. One end of the tubing is connected to the pressure transducer, which is embedded in the soil. The other end of the tubing is connected to the reservoir, which is located at a higher elevation on stable ground, away from construction activity.

The transducer measures the pressure created by the column of liquid in the tubing. The height of the column is equal to the difference in elevation between the transducer and the reservoir. As the transducer settles with the surrounding soil, the height of the column increases and the transducer measures a higher pressure.

Settlement is calculated by converting changes in pressure to millimeters or inches of liquid head.

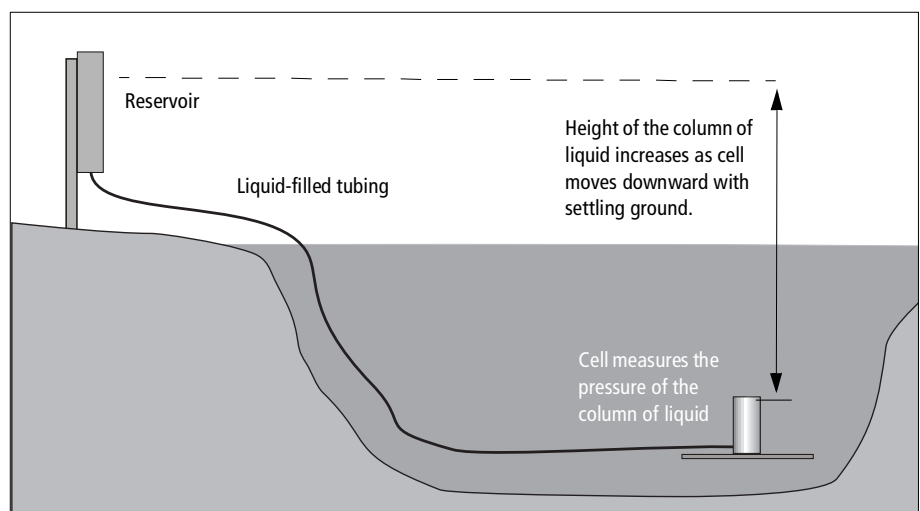

Installation

Components	The components of the system are listed below along with installation suggestions.
VW Settlement Cell	<p>The settlement cell is supplied with tubing and signal cable attached. An optional settlement plate may be included.</p> <ul style="list-style-type: none">• Install the cell in an upright (vertical) position. Non-vertical installation may cause an offset in the data.• Handle the cell with care. Dropping the cell is likely to cause damage.
Liquid-Filled Tubing	<p>Tubing runs between the cell and a reservoir at the surface. It is connected to the reservoir as the final step of installation.</p> <ul style="list-style-type: none">• Avoid making sharp bends in tubing. In general, tubing should run downwards toward the cell. Small ups and downs in the path of the tubing are allowable, but should be avoided if possible.• Keep above-ground runs of tubing as short as possible. This will help minimize temperature changes in the liquid.
Reservoir	<p>The reservoir has quick-connect fittings for tubing from the cell. You may have a simple reservoir that accommodates one cell or a motorized, constant-level reservoir that accepts eight or more cells.</p> <ul style="list-style-type: none">• Be sure to place the reservoir on stable ground. The reservoir serves as the reference for movement of the cell.• Protect the reservoir from extremes of temperature and direct exposure to the sun.
Vented Signal Cable	<p>Vented signal cable runs from the settlement cell to a desiccant chamber at the surface. Non-vented signal cable runs from the desiccant chamber to the readout station or data logger.</p> <ul style="list-style-type: none">• Maintain a radius of at least 4 inches on any bends in the vented signal cable. Tighter bends can pinch the vent tubing and prevent proper operation.• Protect the ends of signal cables so that water cannot enter the cable jacket. Cables should be terminated above ground level.
Desiccant Chamber	<p>The desiccant chamber keeps air in vent tube dry, protecting the transducer from condensation.</p> <ul style="list-style-type: none">• The desiccant chamber should be protected from weather in a vented enclosure. If you install the chamber in a box, be sure to put holes in the box so that the chamber can “breathe.”

Install the Settlement Cell

1. Stake out locations for the settlement cell, the reservoir, and the connecting trench.
2. Excavate the trench to the depth and width specified by the designer. The trench should be deep enough so that the cell will be protected from roller compactors.

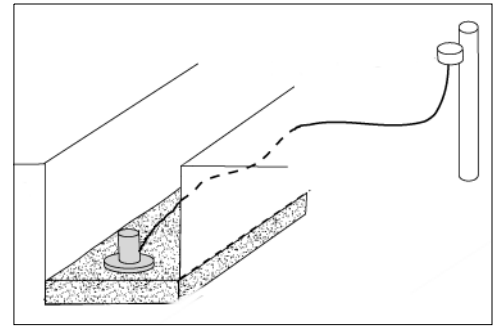

3. Remove sharp stones and rocks and place a 100 mm layer of wet, fine sand on the bottom of the trench.
4. Attach the optional settlement plate to the bottom of the cell. Install the cell in an upright (vertical) position. Non-vertical installation may cause an offset in the data. Note the serial number of the cell.
5. (Optional) Survey the exact elevation of the cell.
6. Cover the top of the cell with at least 100 mm of hand-compacted sand. The most vulnerable point to heavy machinery is the area where cable and tubing enter the cell.

Install Tubing and Cable

1. Route cables and tubing along the trench. Some installers make loops in the cable and tubing where it exits the sensor and at any location where the trench changes direction or elevation.
2. Place a layer of sand over the cable and tubing. Hand compact the sand. Then backfill the remainder of the trench with hand-compacted select fill. Keep in mind that subsequent layers of fill will be compacted by heavy rollers, so the fill that you are placing now must protect the sensor, cable, and tubing.

Install the Reservoir

1. Mount the reservoir on a wall or post that is outside the area affected by settlement. The best location would be one that keeps the reservoir out of direct sunlight and also minimizes the length of tubing that is above ground. The idea is to minimize temperature changes in the liquid. Note that you should probably test the system before mounting the reservoir permanently. See test instructions below.
2. Fill reservoir with deaired liquid. Allow liquid to bleed from quick-connect plugs.
3. Fill quick-connect sockets (on tubing from cell) with deaired liquid, then press onto the quick-connect plugs. Note that liquid is under pressure in the tubing and excess liquid may splash out when you make the connection.

Terminate the Signal Cable	<ol style="list-style-type: none">1. Position the desiccant chamber in protected location.2. Connect signal cable to data logger or terminal box.
Test the System	<p>This test checks the response of the cell to changes in the elevation of the reservoir.</p> <ol style="list-style-type: none">1. Take a reading of the settlement cell.2. Move the reservoir upwards 0.5 meters from its initial position. Take another reading.3. Move the reservoir downwards 0.5 meters from its initial position. Take a third reading.4. Convert the readings to head of water. The second and third readings should show a 0.5 m change in head. Note that the calculated head is approximate, not absolute.5. After testing, mount the reservoir at its permanent elevation
Obtain Initial Readings	<p>Record pressure and temperature from the VW settlement cell as explained in the next section.</p>

Taking Readings

Introduction These instructions tell how to read the vented VW settlement cell with Slope Indicator's portable readouts.

Basic Steps 1. Maintain the level of the liquid in the reservoir: Remove the cap from the reservoir. Remove the plug from the overflow tube. Add water to the reservoir until it runs out the overflow tube. Replace the cap, but leave the overflow tube unplugged.

Adding just water, and not the ethylene glycol mix, is recommended. Adding the mix has the undesirable result of creating a higher concentration of the heavier ethylene glycol.

2. Obtain a settlement reading and a temperature reading from the cell.

3. Replace the plug in the overflow tube.

4. Check the condition of the desiccant in the desiccant chamber. Replace the desiccant if the indicator card shows that it is saturated. The life of the desiccant depends on the environment. You can renew desiccant in an oven: Spread out in a single layer on baking sheet. Bake at 210°C or 425°F for 1 hour, then seal in a glass container while it is still hot.

VW Data Recorder 1. Connect signal cable to the data recorder, as shown below:

Binding Posts	Wire Colors	
VW	Orange	Red
VW	White & Orange	Black
TEMP	Blue	White
TEMP	White & Blue	Green
SHIELD	Shield	Shield

2. Choose Hz + Thermistor.

3. Select the 800-2000 Hz range.

4. The recorder displays a pressure reading in Hz and a temperature reading in degrees C.

VWP Indicator

1. Connect signal cable to the jumper (52611950) from the VWP indicator, as shown in the table below.

Clips	Wire Colors		Function
Red	Orange	Red	VW
Red	White & Orange	Black	VW
Black	Blue	White	TEMP
Black	White & Blue	Green	TEMP

2. Select the 0.8 - 2.0 kHz range with the Sweep key.
3. Select Hz with the Data key. A reading in Hz appears.
4. Read the temperature sensor: Select °C with the Data key. Note that the VWP Indicator reads RTDs only and cannot read thermistors.

DataMate MP

The DataMate MP allows you to choose engineering units for your readings. However, for ease of data reduction, we recommend that you record readings in Hz. See the DataMate MP user manual for directions on programming.

Manual Mode

1. Connect signal cable to the DataMate's bare wire adaptor (BWA), as shown below:

Terminals on BWA or Terminal Box	Wire Colors		Function
5	Blue	White	RTD
6	White & Orange	Black	VW
7	White & Blue	Green	RTD
8	Orange	Red	VW
10	Shield	Shield	Shield

2. Switch on. Press (Manual Mode).
3. Scroll through the list to find "Vibrating Wire Hz."
4. Press  to excite the sensor and display a pressure reading in Hz and a temperature reading in degrees C. Note that this setting provides readings only for RTDs, not thermistors.

Data Reduction

Overview For each settlement measurement, you have collected two readings: a frequency reading and a temperature reading.

1. Calculate the cell pressure by converting the frequency reading to pressure in psi or bar, using the factors supplied on the sensor calibration record. Note that each cell has unique factors.
2. Convert the cell pressure to meters or feet of liquid head.
3. Calculate settlement or heave by subtracting the current head from the initial head.

Step 1 Calculate cell pressure.

Convert the Hz reading to psi or bar using the “manual” ABC factors found on the sensor calibration record:

Cell Pressure = $AF^2 + BF + C$, where F is the sensor reading in Hz.

Step 2 Convert cell pressure to head of water

Convert the corrected cell pressure to head of water using one of the conversion factors below.

Head of Water = Cell Pressure x Conversion Factor

Starting Unit	Multiplier	Resulting Unit
psi	27.73	inch
	2.31	feet
	704.3	mm
	0.7043	m
bar	10215	mm
	10.215	m

Step 3 Calculate Settlement

The change in head of water represents settlement or heave. If the change is positive, settlement has occurred. If the change is negative, heave has occurred:

Change in Water Head = Water Head_{current} - Water Head_{initial}

Correcting for Temperature Effects

For a given pressure, as temperature increases, the sensor outputs a lower frequency. The sensor calibration record provides information that allows you to correct for this effect.

1. Look on the sensor calibration record to find values for “m” and “T_Cal.”
2. Calculate the temperature correction:

$$\text{Temp Correction } t = (T_{\text{Cal}} - T_{\text{Now}}) \times m$$

Where:

Temp Correction t = Correction value in same units as pressure reading.

T-Cal = Reading from the temperature sensor at calibration.

T_Now = Current reading from the temperature sensor.

m = psi per °C . To convert m to another unit, multiply m by the factor used to convert psi to the other unit.

3. The correction value is added to the pressure value

$$\text{Pressure Reading}_{\text{Temp Corrected}} = \text{Pressure Reading} + \text{Temp Correction}$$

Correcting for Density

The deaired liquid supplied with the settlement cell is a 50/50 mixture of water and ethylene glycol, which is about 7% heavier than water.

The table at right shows how the density of the water/ethylene glycol mix varies with temperature. To calculate the actual head of liquid, divide the head of water value by the appropriate value in the table. This is normally 1.07.

Before you decide to make this correction, consider that the temperature of the column of liquid is unlikely to be uniform. In moderate climates, buried tubing that is 5 to 10 feet below the surface tends to stay between 10 and 15 degrees C, but the temperature of the liquid in tubing that is not buried, including the liquid in the reservoir, can vary significantly during the day.

°C	Density Factor
-10	1.0800
-5	1.0775
0	1.0750
5	1.0725
10	1.0700
15	1.0672
20	1.0645
25	1.0617
30	1.0590
35	1.0560
40	1.0530

$$\text{Head of 50/50 Ethylene Glycol/Water} = \text{Water Head} / \text{Density Factor}$$

Acceptance Test

Introduction The main purpose of an acceptance test is to provide reasonable assurance that a sensor is functioning properly. Unless you have access to sophisticated test facilities and calibration equipment, acceptance tests should not be expected to achieve the accuracy and precision of the calibration data provided on the sensor calibration record.

Thus when you evaluate the results of an acceptance test, look for obvious non-conformance rather than an exact match between your data and the data on the calibration record.

- Test Procedure**
1. Ideally, this test would be conducted in a draft-free room the cell and tubing are allowed to reach temperature equilibrium.
 2. The cell should be stood vertically and tubing should be raised above the level of the cell.
 3. Measure the distance between the top of the tubing and the top of the cell, as shown in drawing.
 4. Connect signal cable to readout and obtain a frequency reading. Be sure that the vent tube is open to atmosphere. Also obtain a temperature reading.
 5. Use the data reduction procedures given in the previous section to calculate cell pressure, head of water, and to correct for temperature and density.
 6. The difference between the measured distance and the calculated head of liquid should compare within two inches or 50 mm.

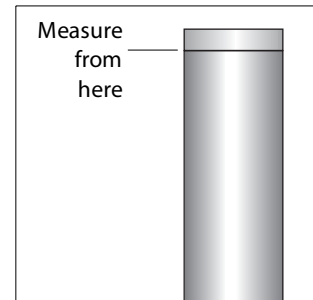

Diagnostics

Introduction Perform the tests below to check the sensor and cable.

No Reading Set your handheld multimeter to a low-ohm range (5k ohm).

- Measure the resistance between the two VW wires (orange and white-and-orange). A normal reading should be about 300 ohms. If the reading is very high or infinite, the coil is damaged (or the cable is severed). If the reading is very low, the cable may have been crushed and a short has developed.
- Measure the resistance between the temperature sensor wires (blue and white). Thermistors should read about 3000 ohms. RTDs should read about 2000 ohms. If the reading is very high or infinite, the temperature device is damaged (or the cable is severed). If the reading is very low, the cable may have been crushed and a short has developed.

Unstable Reading Set your handheld multimeter to a high range (10 or 20 M ohm).

- Measure the resistance between a VW wire and a Temp wire. The reading should be infinite or out of range.
- Measure the resistance between any of the colored wires and the drain (shield) wire. The reading should be infinite or out of range.
- Measure the resistance between the shield wires of two installed VW sensors. Wires must be disconnected from data logger or terminal box to make this test. The reading should be very high or infinite. A lower reading indicates the presence of a ground loop.
- Other sources of unstable readings are electrical noise from nearby power lines, radio transmitters, or motors. Also, over ranged or shocked instruments can exhibit this problem.

Splicing Vented Signal Cable

Introduction If you have a choice, consider splicing the non-vented signal cable rather than the vented cable. If you must splice the vented cable, you should have splice kit #50614415, a soldering iron, solder, and a heated blower.

Prepare Wires Strip back 3 or more inches of cable jacket and cut conductors different lengths to minimize the overall diameter of the splice. Strip about 0.3 inches of insulation from each conductor.



- Splice Wires and Tubing**
1. Slide large cold-shrink insulator onto cable.
 2. Cut short lengths of heat shrink tubing to cover each splice and slide onto wires.
 3. Solder wires using rosin-core solder. Hold wires with clamps or a soldering jig. Solder drain wires, too. Crimp connectors may be supplied in the kit. You may use these if you cannot solder.
 4. Apply oxidation inhibitor to wires, if specified.
 5. Slide heat shrink tubing over soldered wires and apply heat.
 6. Push tubing ends onto brass union.

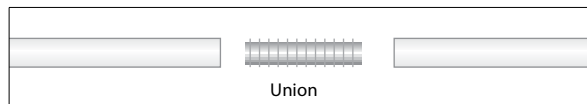

7. Wrap mastic pad around splices. It is important to make the diameter of the wrap as small and even as possible. Wrap rubber tape over spliced areas from cable jacket to cable jacket.

- Release Cold Shrink Insulator**
1. Coat wrapped area with grease.
 2. Center cold-shrink insulator over wrapped area.
 3. Hold cold shrink insulator in position and pull on the release tab to unwind the supporting core of the insulator. You must pull and unwind (counter clockwise) at the same time.
 4. The cold shrink insulator collapses onto the spliced area to complete the splice.

Terminating Vented Signal Cable

Overview Vented signal cable runs between the sensor and the desiccant chamber. The vent tube must be terminated inside the desiccant chamber to prevent the entry of moisture. The signal conductors of the vented cable are connected to non-vented cable which then exits the desiccant chamber and runs to the readout station or data logger.

Open Desiccant Chamber

1. Remove the lid by unscrewing the four retaining screws. Pour desiccant into airtight container.
2. Loosen gland seals and push out of the way.
3. Cut out old splice and remove filter from vent tube.
4. Loosen cable glands and pull cable out of chamber.

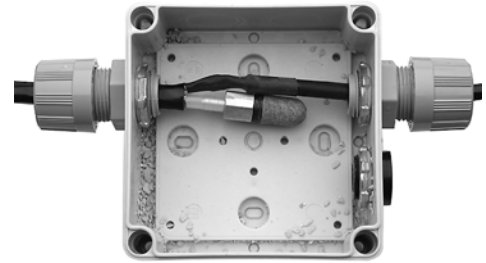

Prepare Cable Ends

1. Cut vented cable to the proper length. Strip the jacket back about two inches to expose conductors and vent tube. Strip about 0.5 inch of insulation from each conductor.
2. Cut off the exposed vent tube so about 1 inch remains.
3. Strip 1.5-inches of the jacket on the non-vented cable. Strip about 0.5 inch of insulation from each conductor.
4. Slide cables through cable glands and into desiccant chamber. You may need to slide components of cable glands onto cables first. Some lubrication may be required.

Splice Cables

1. Insert small filter into the vent tube. You may have to soften the vent tube with a little heat.
2. Identify matching conductors and twist ends together. Secure with wire nuts or solder.
3. Wrap spliced cables with electrical tape.

Assemble Chamber

4. Fill the chamber with desiccant and screw the lid.

Constant-Level Reservoir

Introduction This section tells how to install the motorized, constant-level reservoir.

- Components**
- Reservoir with two tanks and an overflow pump. This is enclosed in a box.
 - Connection manifold (one or more). The connection manifold is enclosed in a separate box.
 - Tubing to connect manifolds to the reservoir.
 - De-aired liquid to fill reservoir and manifolds.

- Requirements**
- AC power for the overflow pump.

Operation The constant-level reservoir has a reference tank with an overflow tube and a supply tank with a pump. Liquid is pumped slowly from the supply tank to the reference tank. The level in the reference tank remains constant because excess water flows out the overflow tube and back into the supply tank. Liquid must be added to the supply tank from time to time to replace liquid that has evaporated. Level sensors in the tanks signal the data logger when the liquid level is too low.

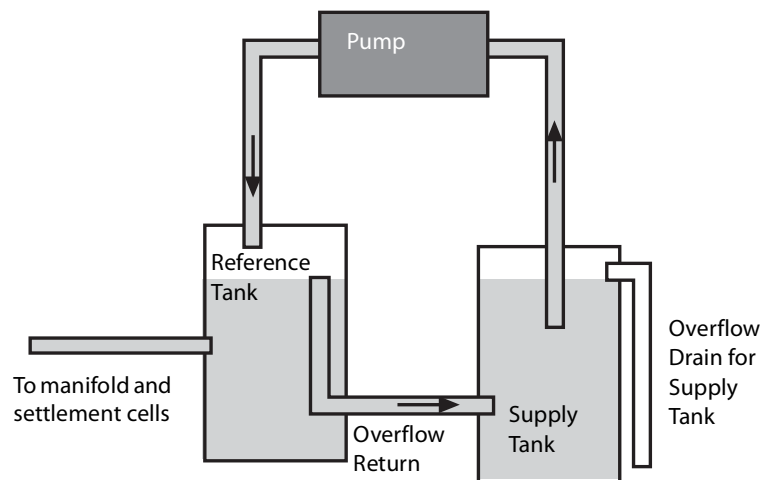

Setup The schematic below shows the basic components and layout of the constant-level reservoir.

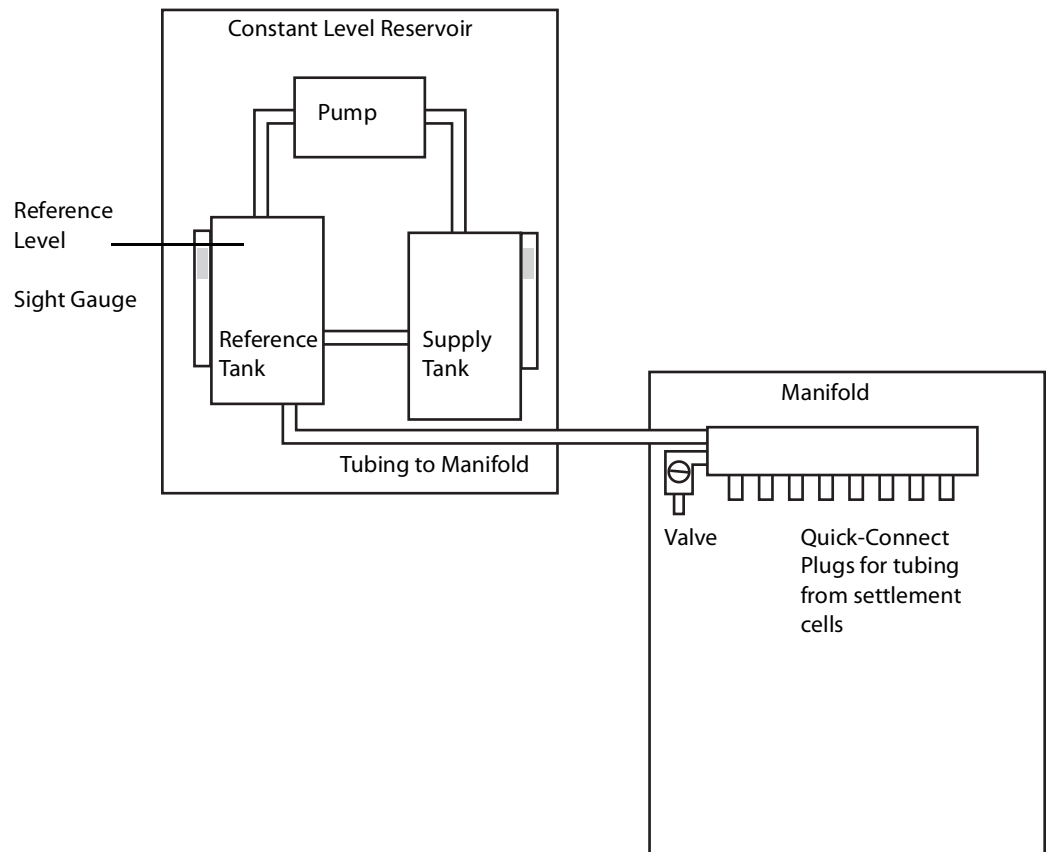

1. Mount reservoir and the manifold on a wall. Manifold must be mounted at lower elevation than the reservoir. Devise means of protecting reservoir and manifold from direct sunlight.
2. Connect tubing from reference tank to manifold. Open valve of manifold so that air can escape.
3. Fill system with liquid, starting at the reference tank and supply tank. For now, check that overflow tube on supply tank is capped. When both tanks are full, liquid flows through tubing to manifold and eventually exits from valve at end of manifold when system is full.
4. Bleed liquid through each quick connect plug to ensure that air is eliminated from system.
5. If there is a second manifold, connect it to the first manifold, then fill with liquid and eliminate air from system.
6. Connect settlement cells to manifolds. Tubing from settlement cell is terminated in quick-connect sockets. Fill each quick connect socket with deaired liquid before you connect it to the manifold. Connect to

any available plugs on the manifold.

7. Connect reservoir level switches to CR10 system. Connect settlement cell signal cables to CR10 system. Electrical connections are provided in a different document.
8. Start pump. The pump moves liquid from the reservoir tank into the overflow tank. It works very slowly (3 ml per minute) to maintain a constant level of liquid in the overflow tank. Any excess liquid drains out of the overflow tank and is returned to the reservoir tank. Because the pump works so slowly, it may take some time for the overflow action to begin. It is difficult to see the overflow, so to verify that the pump is working, you may have to touch to top of the overflow tube to feel the water.
9. Check level of liquid in supply tank. Uncap overflow tube to allow excess liquid to drain away. Overflow tube should remain uncapped.

Electrical Connections

All electrical connections are documented in a wiring diagram supplied with the data logger.