

# Multi-Level VW Piezometer

52611199

Copyright ©2004 Slope Indicator Company. All Rights Reserved.

This equipment should be installed, maintained, and operated by technically qualified personnel. Any errors or omissions in data, or the interpretation of data, are not the responsibility of Slope Indicator Company. The information herein is subject to change without notification.

This document contains information that is proprietary to Slope Indicator company and is subject to return upon request. It is transmitted for the sole purpose of aiding the transaction of business between Slope Indicator Company and the recipient. All information, data, designs, and drawings contained herein are proprietary to and the property of Slope Indicator Company, and may not be reproduced or copied in any form, by photocopy or any other means, including disclosure to outside parties, directly or indirectly, without permission in writing from Slope Indicator Company.

## **SLOPE INDICATOR**

12123 Harbour Reach Drive  
Mukilteo, Washington, USA, 98275  
Tel: 425-493-6200 Fax: 425-493-6250  
E-mail: [solutions@slope.com](mailto:solutions@slope.com)  
Website: [www.slopeindicator.com](http://www.slopeindicator.com)

---

# Contents

Introduction.....	1
Installation .....	4
Taking Readings .....	8
Data Reduction.....	10
Acceptance Test .....	13
Diagnostics.....	14

# Introduction

## Operation

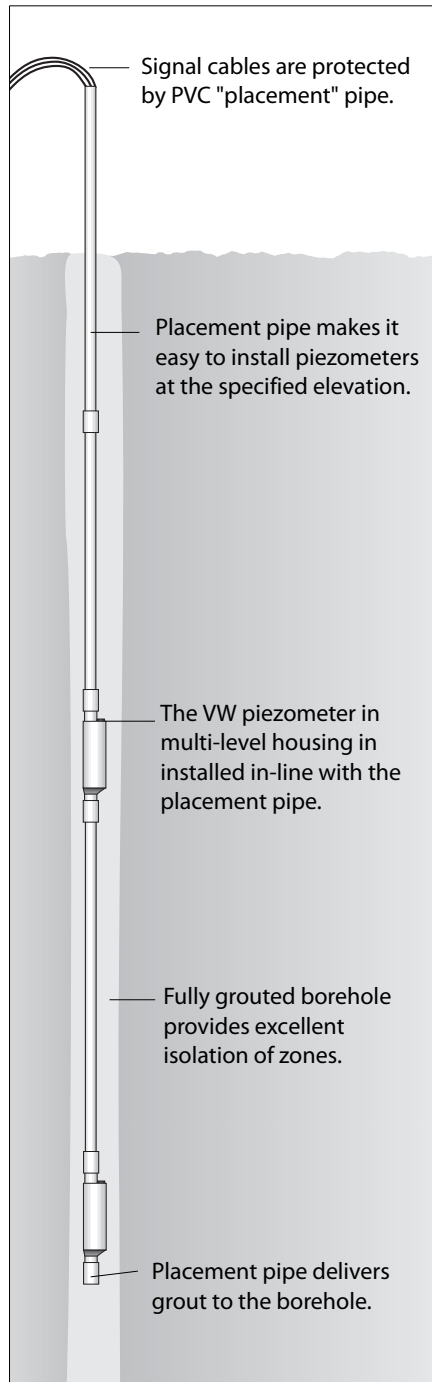

Multi-Level VW Piezometers are used to monitor pore-water pressure at different zones in the borehole.

In a traditional multi-level installation, each piezometer is embedded in a sand intake zone and sealed from other zones with a bentonite plug. Cables from the piezometers pass through the different zones on the way to the surface.

The traditional multi-level installation method suffers from a number of well-known problems. These problems are either avoided or solved by Slope Indicator's multilevel system, as explained below:

- In the traditional method, placing sensors at their intended depth is difficult, and the difficulty increases with the number of sensors. With the multi-level system, piezometers are installed in-line with PVC pipe. The pipe controls the elevation and relative spacing of the piezometers.
- In the traditional method, placement of sand intake zones and bentonite seals is time-consuming and uncertain. The multi-level system entirely eliminates sand intake zones and bentonite seals. Instead, the entire borehole is filled with a bentonite-cement grout.
- In the traditional method, signal cables from the piezometers pass through the seals that isolate the various intake zones. The cables can form channels for migration of water between zones. With the multi-level system, signal cables from each piezometer run to the surface through the PVC placement pipe. The pipe itself is watertight and is later filled with grout. This completely eliminates communication between zones.
- In the traditional method, cables can be twisted and permanently damaged in the process of withdrawing drill casing or auger sections. With the multi-level system, cables are encased in the PVC pipe and are much less likely to be twisted or damaged.

## Components

The system consists of a number of VW piezometers in multi-level housings, a grout fitting, and some user-supplied components, which are listed on the next page.

### VW Piezometer in Multi-Level Housing

The central component of the system is the VW piezometer. It is fixed to a short section of "in-line" pipe, as shown in the drawing. The pipe has couplings at top and bottom so that it can be assembled in-line with the PVC placement pipe.

Signal cable from the piezometer runs into the in-line pipe through a sealed entry and then exits from the top of the in-line pipe. Signal cables from any piezometers below pass through the in-line pipe.

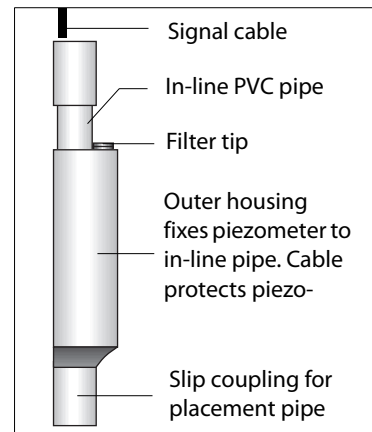

The VW piezometer is mounted with its filter tip facing upwards so that air bubbles cannot form in front of the diaphragm. The diaphragm of the piezometer is about 4 inches (102mm) below middle of the upper coupling.

Each piezometer is identified by a serial number. The serial number appears on the multilevel housing and also on a label that is wrapped around the top of the signal cable.

Serial numbers are important for data reduction and must not be lost. After installation, the only means of identifying the piezometer is the label wrapped around the top of the signal cable. Take care of this label during and after installation.

### Grout-Fitting

The placement pipe can be used to deliver the grout backfill. An accessory grout fitting, shown at right, is attached to the placement pipe. Signal cables exit the top of the fitting, and grout is pumped through a grout port.

The fitting can be removed and used for the next multi-level installation.

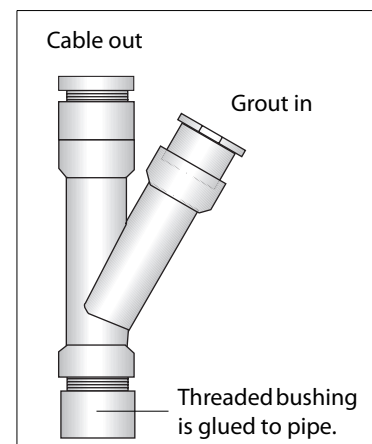

---

## User Supplied Components

- PVC pipe and slip couplings to make the "placement" pipe. The slip couplings on the multilevel housing accept 1.25" schedule 40 PVC pipe.
- PVC cement to assemble the placement pipe. The label on the can tells how much cement you will need for pipe.
- Safety cable (optional) to attach to the deepest piezometer to prevent loss of the system down hole or to retrieve the system.
- Tape to protect ends of signal cables.
- Rag to plug the top of the grout fitting.
- A tubing cutter to cut the PVC pipe off at the required height without damaging the cables.
- Tremie pipe (Optional). The placement pipe is intended to be used to deliver grout. However, if it is not practical to grout the entire borehole all at once, you can install a tremie pipe or poly hose along with the multi-level piezometer pipe.

If you use a tremie pipe, it is important to install it at the same time as the placement pipe. If you try to lower a tremie pipe after the piezometer are installed, there is a high risk of damaging them.

# Installation

## Preparation

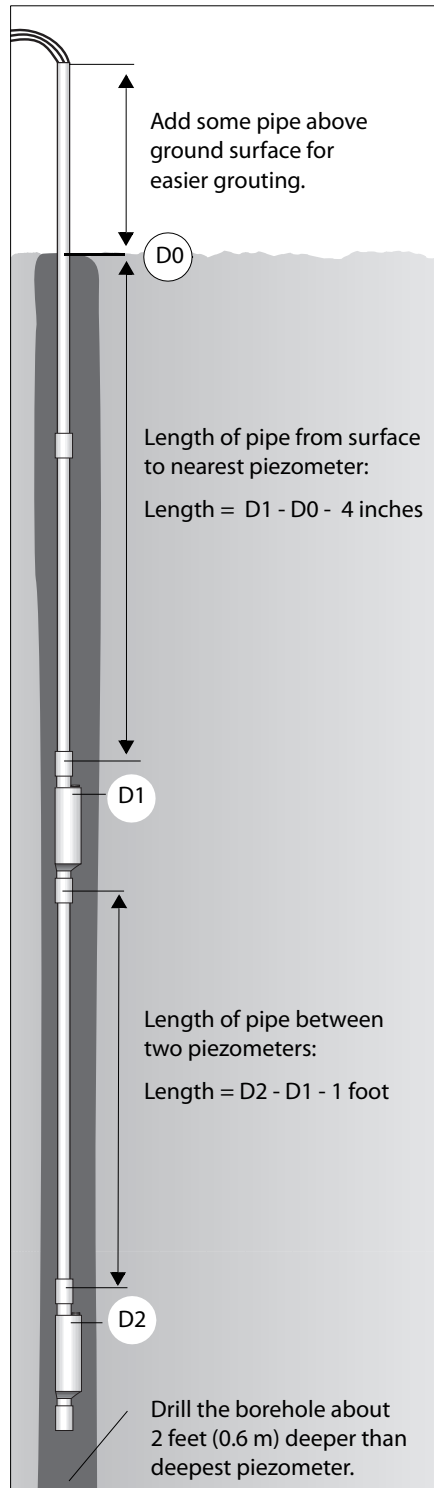

1. Look at project specifications to determine the elevation required for each piezometer. Drill the borehole at least two feet (0.6 m) deeper than the deepest piezometer so you can position the deepest piezometer properly and have room for grout to flow out the end of the placement pipe.
2. Check that the correct lengths of cable are attached to each piezometer, and then mark each piezometer for order of installation, using its cable length as a guide.

3. Calculate the length of pipe needed to place the diaphragm of each piezometer at the required elevation. The drawing at right shows that the diaphragm is about 4 inches (102mm) below the middle of the upper slip coupling. The total length of the housing is 12" (305mm).

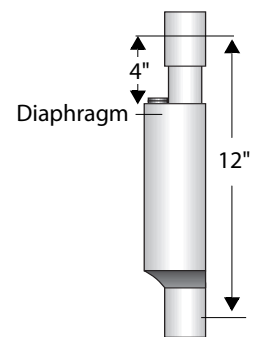

In the drawing at left, D0 is the ground surface. D1 and D2 are depths specified for the piezometers.

- Pipe required between surface and nearest piezometer:  
Length =  $D1 - D0 - 4$  inches
- Pipe required between two piezometers:  
Length =  $D2 - D1 - 12$  inches

Cut the placement pipe to the lengths required. Consider making the top section of pipe longer, so that it will extend above ground for easier connection to a grout pump.

4. Group piezometers, placement pipe, and couplings together in order of installation. You may find it useful to number each piece so that you will not overlook a piece during installation.
5. Wrap the ends of signal cable with tape to protect them from water. Try to minimize the diameter of the protected ends, since you must push them through the placement pipe. The drawing shows one way to bundle cables while keeping the overall diameter as small as possible.

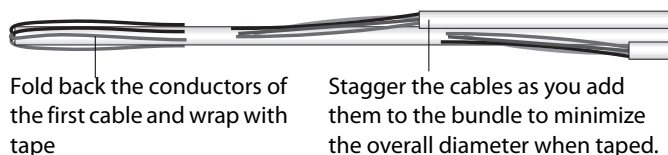

## Assembly and Installation

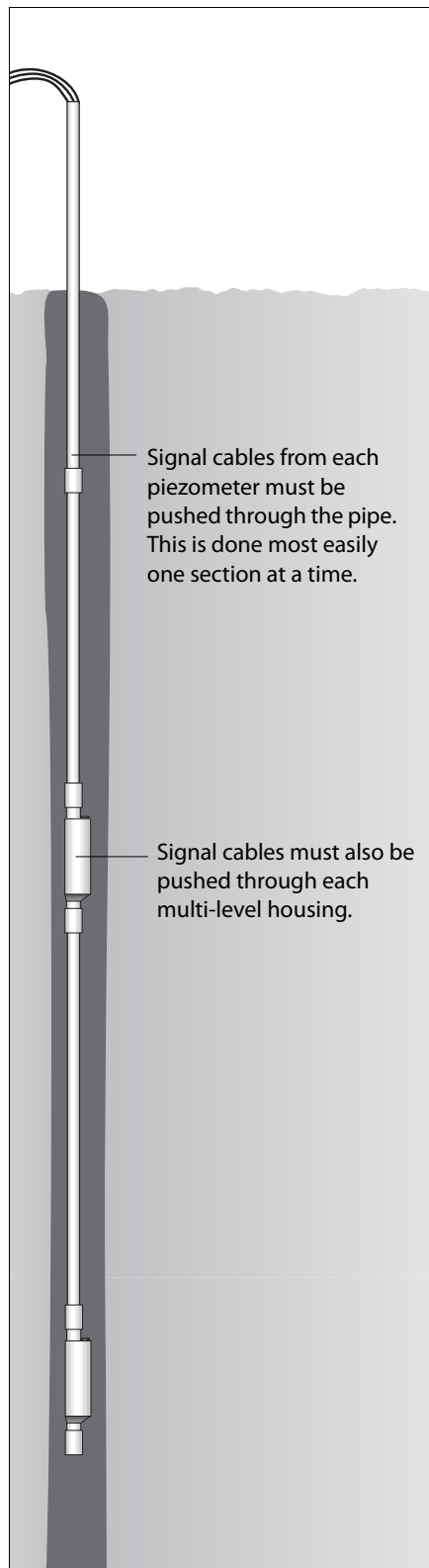

1. Start with the deepest piezometer. Push its signal cable through the placement pipe grouped with that piezometer. With longer cables, it may be easiest to lay out the cable, push pipe and couplings onto the end of the cable, and then "walk" them toward the piezometer.

Assemble the pipe using PVC cement. There is a limit to how much pre-assembly is possible, since you must lift the pipe and put it into the borehole. If you are using a safety line, this is the time to secure it to the bottom of the pipe.

2. When the piezometer and placement pipe are positioned and ready to go down hole, pull the knurled filter tip off the piezometer and fill the cavity with clean water. No other "saturation" is required.

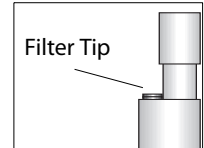

3. Push the piezometer and pipe downhole, adding lengths of pipe as required. As mentioned before, signal cable must be fed through each length of pipe. Clamp the last section of pipe at the top of the borehole and prepare to add the second piezometer.
4. Locate the second piezometer. Feed the signal cable from the first piezometer through the body of the second piezometer. Glue the second piezometer onto the placement pipe that is clamped at the top of the borehole. Now add placement pipe to this piezometer, pushing cables through each section of pipe. Push the pipe downhole as you work.
5. Locate the next piezometer and repeat the steps above. Continue until all piezometers and placement pipe have been installed. The last section of pipe should extend above ground level.

## Grouting

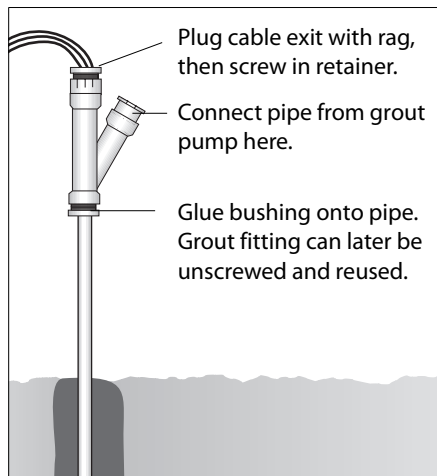

These instructions tell how to grout the borehole using the placement pipe to deliver the grout.

1. Install the grout fitting: Push signal cables through the top of the fitting, as shown in the drawing. Glue the grout fitting to the placement pipe. Then plug the cable exit with a rag and screw in the retainer.
2. Prepare grout using one of the recipes on the next page. We recommend mixing cement and water first and adding bentonite last. This (unusual) order of mixing allows adding more bentonite, which is a good thing in this application. It also provides more control over the thickness of the grout, which is important for easy, low-pressure pumping. See the recipes on the next page for details.
3. Connect grout pipe to the grout port shown in the drawing and pump grout into the placement pipe. Keep pressure fairly low (below 100 psi).
4. Halt pump with grout appears at the top of the borehole. Remove grout pipe from grout fitting.
5. Unscrew retainer and remove rag from grout fitting. If you want to re-use the grout fitting, unscrew it. Do not twist cables when you do this.
6. Use a tubing cutter to cut off excess placement pipe and then pull it off the signal cable. If you use some other cutter, be very careful to avoid cutting into the signal cables.
7. Terminate the installation according to project specifications. If you must cut off the ends of the signal cable, be sure to keep track of serial numbers.

---

## Grout Recipes

Here are grout recipes to use as a starting point. The notes explain the how and why of the recipes.

### Grout Mix for Hard to Medium Soils

Materials	Weight	Ratio by Weight
Portland cement	94 lb (1 bag)	1
Water	30 gallons	2.5
Bentonite	25 lb (as required)	0.3

### Grout Mix for Soft Soils

Materials	Weight	Ratio by Weight
Portland cement	94 lb (1 bag)	1
Water	75 gallons	6.6
Bentonite	39 lb (as required)	0.4

### Read These Notes

- Mix cement with water first. Then mix in bentonite. Adjust the amount of bentonite to produce a grout with the consistency of heavy cream. The bentonite quantities are a starting point only. The exact quantity of bentonite needed to make this "heavy cream" mix will vary with the type used, the method of mixing, and the pH of the water.
- If you have a Marsh funnel, the Marsh number of the liquid grout should be about 55 seconds.
- If you mix bentonite with water first and then add cement, the mix will be too thick. To thin the mix, you'll have to add water. This increases permeability, which is not desirable in this application. It also increases the risk of a flash-set.
- If the grout is too thin, it will shrink later, or the solids and the water will separate.

---

# Taking Readings

**Introduction** Sufficient time should be allowed for the grout to set before initial readings are taken. Datum readings can be taken when periodic readings have stabilized.

These instructions tell how to read the VW piezometer with Slope Indicator's portable readouts. Instructions on reading piezometers with a data logger can be found on in the tech notes on Slope Indicator's website: [www.slopeindicator.com](http://www.slopeindicator.com).

## Reading with the VW Data Recorder

1. Connect signal cable to the data recorder:

Binding Posts	Wire Colors	
VW	Orange	Red
VW	White & Orange	Black
TEMP	Blue	White
TEMP	White & Blue	Green
SHIELD	Shield	Shield

2. Choose Hz + RTD or Hz + Thermistor.
3. Select the 1400-3500 Hz range.
4. The recorder displays a pressure reading in Hz and a temperature reading in degrees C.

## Reading with the VWP Indicator

1. Connect signal cable to the jumper #52611950, from the VWP indicator, as shown in the table below.

Clips	Wire Colors		Function
Red	Orange	Red	VW
Red	White & Orange	Black	VW
Black	Blue	White	TEMP
Black	White & Blue	Green	TEMP



2. Read the VW sensor: Select the 1.4-3.5 kHz range with the Sweep key. Select Hz with the Data key.
3. Read the temperature sensor: Select °C with the Data key. Note that the VWP Indicator reads RTDs only and cannot read thermistors.

---

## Reading with the DataMate MP

The DataMate MP allows you to choose engineering units for your readings. However, for ease of data reduction, we recommend that you record readings in Hz. See the DataMate MP manual for directions on programming.

### Manual Mode

1. Connect the DataMate to the sensor (see connection table below).
2. Switch on. Press  (Manual Mode).
3. Scroll through the list to find “Vibrating Wire Hz.”
4. Press  to excite the sensor and display a pressure reading in Hz and a temperature reading in degrees C. Note that this provides readings only for RTDs, not thermistors

### Connections

The DataMate jumper cable has a universal connector that connects directly to a universal terminal box or to signal cables that are terminated with a universal connector. A bare-wire adapter (BWA) is also supplied with the DataMate. It allows connection to wires of the signal cable as shown below:

Terminals on BWA or Terminal Box	Wire Colors		Function
5	Blue	White	RTD
6	White & Orange	Black	VW
7	White & Blue	Green	RTD
8	Orange	Red	VW
10	Shield	Shield	Shield

---

# Data Reduction

**Overview** Readings from the VW piezometer are typically in Hz, rather than in units of pressure. To convert the Hz reading to units of pressure, you must apply factors listed on the sensor calibration record.

There are two corrections that you can make to the calculated pressure reading. Your application determines whether these corrections are required or not. Corrections are listed later in this chapter.

**Sensor Calibration Record** Each VW piezometer has a unique calibration. Use the sensor serial number to match the sensor with its calibration record.

**Conversion Factors** **ABC Factors:** Your calibration record may list these as “manual” ABC factors. They are used to convert Hz readings to various engineering units. They can be used in programmable readouts, such as the DataMate MP, or they can be used in spreadsheets. Keep in mind that it is always a good idea to record unprocessed readings (Hz and °C). Processing on your PC is almost always preferable to processing in the readout or data logger.

**IDA ABC Factors:** These factors are used to program “retired” readouts, such as the VS DataMate and the IDA system. These readouts can be programmed to provide readings in Hz and °C.

**Temperature Correction Factors** These two factors can be used to correct the pressure reading for temperature effects. These factors are applied to the temperature reading that you obtain from the sensor’s built-in thermistor or RTD. Older calibration records list a temperature coefficient.

**Temperature Offset** The temperature offset shows the difference between a reading taken with the piezometer’s built-in thermistor or RTD and a reading taken with an NIST-traceable temperature sensor.

If you are interested in more accurate temperature values, add the offset to your temperature readings. However, do not add the offset when you are calculating temperature corrections.

## Converting Hz Readings to Units of Pressure

1. Choose a unit of pressure from the ABC factors listed on the sensor calibration record.
2. Apply the factors as follows. Apply the factors as follows:

$$\text{Pressure Reading} = Ax^2 + Bx + C$$

Where x is the Hz reading and A, B, and C are factors listed on the sensor calibration record

## Finding Changes in Pressure

Subtract the initial reading from the current reading. A positive value indicates increased pressure. A negative reading indicates decreased pressure.

$$\Delta\text{Pressure} = \text{Pressure}_{\text{current}} - \text{Pressure}_{\text{initial}}$$

## Elevation Correction (Optional)

Barometric pressure drops about 0.5 psi for every 1000 feet of elevation. The piezometer, which reads zero at sea level, will show a negative pressure if taken to higher altitudes. sure.

### Is this correction needed?

If you are monitoring changes in pore-water pressure, you do not need elevation corrections. You can think of elevation as a kind of offset that is eliminated when you calculate changes.

If you require the absolute pore-water pressure, then you should apply the elevation correction.

### Calculating the elevation correction

1. The equation below works with meters of elevation:

$$\text{Elevation Correction} = \text{Conversion Factor} \times \left[ 1 - \left( 1 - \frac{\text{Elevation in meters}}{44307.69231} \right)^{5.5328} \right]$$

For a correction in this unit:	Use this conversion factor:
bar	1.0132
kPa	101.33
psi	14.696

2. Add the elevation correction to the pressure reading.

$$\text{Corrected Pressure} = \text{Pressure Reading} + \text{Elevation Correction}$$

---

## Temperature Correction (Optional)

Temperature can affect the response of the piezometer. The sensor calibration record lists correction factors that you can apply to the RTD or thermistor reading.

### Is this correction needed?

Is your piezometer sealed in a borehole or buried in fill? Since there is not much variation in underground temperatures, temperature corrections are probably not useful.

Is your piezometer installed in shallow water in a standpipe or well? The piezometer will follow temperature changes of the water that surrounds it. In this case, you may want to correct for temperature effects.

### Calculating a temperature correction

1. Find the temperature factors on the sensor calibration record. There are three factors: m, b, (both in PSI) and TempOffset. You can convert m and b to other units, if necessary.

To convert from psi to:	Multiply m and b factors by:
kPa	6.895
bar	0.06895
meters of water	0.7037 (water at 15.5 °C)

2. Calculate the temperature correction:

$$\text{Temperature Correction} = m \times (\text{Temperature Reading} - \text{TempOffset}) + b$$

Where m, b, and TempOffset are values listed on the calibration sheet and TemperatureReading is the current reading in degrees C obtained from the piezometer's built-in thermistor or RTD.

3. Apply the temperature correction:

$$\text{Corrected Pressure} = \text{Pressure} + \text{Temperature Correction}$$

---

# Acceptance Test

- Purpose of the Test**     The main purpose of an acceptance test is to provide reasonable assurance that a sensor is functioning properly. Unless you have access to sophisticated test facilities and calibration equipment, acceptance tests should not be expected to achieve the precision of the data on the sensor calibration record. Thus when you evaluate the results of an acceptance test, look for obvious non-conformance rather than an exact match between your data and the data on the calibration record.
- Quick Zero Check**
1. To obtain the best results, the piezometer should be allowed to adjust to ambient temperature, and it should not be handled during the test.
  2. Connect the signal cable to readout and obtain a frequency reading. Check that you have obtained a repeatable reading.
  3. Apply calibration factors to convert the frequency to a pressure reading in psi.
  4. If your local elevation is above sea level, the pressure reading that you obtain will most likely be negative because the sensor calibration is referenced to one standard atmosphere (sea level). To calculate a correction for your elevation, allowing 0.5 psi for every 1,000 feet of elevation above sea level (1.15 mb per 10 m). Add the correction to your reading. For example, if you are at 5,000 feet, you would add a correction of 2.5 psi to the pressure reading. (See the chapter on data reduction for more details). To make a more precise check, you would correct for the exact altitude, the barometric pressure, and the temperature.
  5. The piezometer is working satisfactorily if the difference between the corrected pressure and zero is within 2 percent of the full scale of the piezometer (2 psi for a 100 psi piezometer).

---

# Diagnostics

**Introduction** Perform the tests below to diagnose what is wrong with your piezometer. Unfortunately, after the instrument has been installed, there is often no remedial action possible.

**No Reading** Set your handheld multi meter to a low-ohm range (5k ohm).

- Measure the resistance between the two VW wires (orange and white-and-orange). A normal reading should be about 300 ohms. If the reading is very high or infinite, the coil is damaged (or the cable is severed). If the reading is very low, the cable may have been crushed and a short has developed.
- Measure the resistance between the temperature sensor wires (blue and white). Thermistors should read about 3000 ohms. RTDs should read about 2000 ohms. If the reading is very high or infinite, the temperature device is damaged (or the cable is severed). If the reading is very low, the cable may have been crushed and a short has developed.

**Unstable Reading** Set your handheld multimeter to a high range (10 or 20 M ohm).

- Measure the resistance between a VW wire and a Temp wire. The reading should be infinite or out of range.
- Measure the resistance between any of the colored wires and the drain (shield) wire. The reading should be infinite or out of range.
- Measure the resistance between the shield wires of two installed VW sensors. Wires must be disconnected from data logger or terminal box to make this test. The reading should be very high or infinite. A lower reading indicates the presence of a ground loop.
- Other sources of unstable readings are electrical noise from nearby power lines, radio transmitters, or motors. Also, over ranged or shocked instruments can exhibit this problem.