

Pneumatic Piezometer 51417799

Copyright ©2000 Slope Indicator Company. All Rights Reserved.

This equipment should be installed, maintained, and operated by technically qualified personnel. Any errors or omissions in data, or the interpretation of data, are not the responsibility of Slope Indicator Company. The information herein is subject to change without notification.

This document contains information that is proprietary to Slope Indicator company and is subject to return upon request. It is transmitted for the sole purpose of aiding the transaction of business between Slope Indicator Company and the recipient. All information, data, designs, and drawings contained herein are proprietary to and the property of Slope Indicator Company, and may not be reproduced or copied in any form, by photocopy or any other means, including disclosure to outside parties, directly or indirectly, without permission in writing from Slope Indicator Company.

Slope Indicator Company
A Boart Longyear Group Company
3450 Monte Villa Parkway
Bothell, WA 98021-8906 USA
Tel: 425-806-2200 Fax: 425-806-2250
E-mail: solutions@slope.com
Website: www.slopeindicator.com



Contents

Introduction.....	1
Installing the Piezometer	2
Reading the Piezometer	7
Troubleshooting.....	14
How to Splice Tubing	15
1.5 Inch Piezometer.....	16

Introduction

Overview	<p>Pneumatic piezometers are sealed in boreholes or embedded in fills to measure pore water pressure. Components for a typical pneumatic piezometer system include:</p> <ul style="list-style-type: none">• Pneumatic Piezometer• Tubing and Quick-Connect Fittings• Terminal Pipe or Terminal Box (Optional)• Pneumatic Indicator
Piezometers	<p>The piezometer, sometimes called a piezometer tip, is sealed in a borehole, embedded in soil, or suspended in a well.</p>
Tubing	<p>Tubing carries gas to and from the piezometer. Slope Indicator piezometers use twin tubing.</p>
Terminals	<p>Tubing from piezometers are often terminated at a central read-out station. The terminal may be a simple enclosure or a more elaborate panel.</p>
Pneumatic Indicators	<p>The portable pneumatic indicator is carried to the readout station. The indicator contains an internal tank that holds the compressed nitrogen gas which is used to activate and read the piezometer.</p>

Installing the Piezometer

General Notes Here are some ideas to keep in mind as you install the piezometers.

- Sensor Care**
- Handle the piezometer with care.
 - If you are working in cold weather, do not allow a water-filled piezometer or a saturated filter to freeze.

- Tubing Care**
- Store tubing where it is dry and safe from rodents and traffic.
 - Handle tubing carefully. Don't lay the tubing across roads with traffic. Avoid dragging tubing over rocks and sharp surfaces. Do not pull hard on the tubing. Avoid making small radius bends or kinks in the tubing.
 - Mark tubing carefully for positive identification later. Also make a mark (colored tape) on tubing so that you know when the piezometer has reached its intended depth.
 - Protect quick-connectors on the ends of tubing. Keep them clean and dry.

- Backfilling the Borehole**
- In traditional borehole installations, a sand intake zone is formed around the piezometer and a bentonite seal is placed above the sand zone. The seal isolates pore-water pressure at the piezometer and prevents grout backfill from displacing the sand and blocking the entry of water.
 - There is some evidence that the sand intake zone is not needed. The piezometer can be grouted in using a bentonite-cement grout. The filter needs no protection because there is no in-flow of water. For more information on this topic, visit the technical support section of www.slopeindicator.com. Click on "tech notes" and find the article called "Grouting-in Piezometers."
 - If drill casing is used to hold the borehole open, it must be pulled out as backfill is placed. Use care when pulling casing so that you do not twist and damage the tubing.

Obtaining the Initial Reading

Drilling a borehole and backfilling it temporarily changes the pore-water pressure in the ground, so readings taken immediately after installation will not be good datum readings. Recovery of the natural pore-water pressure make take a few hours to a few weeks, depending on the permeability of the soil. Recovery is signalled by stable readings over a period of a few days. A datum reading can then be obtained.

Saturating Filters

- Most piezometers are supplied with filters that have a pore size of 50 to 60 microns. These filters pass both air and water, so they do not require elaborate saturation procedures.
- “Embankment” piezometers are sometimes supplied with a large cylindrical high-air entry filter. These filters are intended to prevent the entry of air into the piezometer, but are effective in this task only if they remain saturated. The initial saturation requires time and care.

To saturate a high-air entry filter, remove the filter by unscrewing the pointed tip of the piezometer. Saturate it using one of the methods below. Then reassemble the piezometer underwater and bag it in deaired water to maintain saturation until installation.

Immersion Method: Prepare deaired water. Stopper the ends of the filter so that water can act only on the outside of the filter. Allow air to vent through the stopper at the top of the filter, as shown in the drawing. Immerse filter for approximately 24 hours.

Vacuum Method: This method probably provides the most complete saturation. The filter is placed in a chamber and a vacuum is applied. The chamber is then slowly flooded with deaired water. As the water level rises, any remaining air is driven out of the filter.

Water can be deaired by bring it to a boil and applying a vacuum. The water must then be cooled before safe use. For smaller quantities of de-aired water, we recommend using the Nold DeAerator from theWalter Nold Company. It combines propeller cavitation with a vacuum to deair the water rapidly and works at room temperature, so the deaired water is immediately usable.

Borehole Installation (traditional method)

Install as directed by project specifications. The instructions below assume that the piezometer will be installed at the bottom of the borehole.

1. Drill the borehole below the required depth of the piezometer. Flush the borehole with water or biodegradable drilling mud.
2. Form a sand intake zone: You must pull drill casing slightly to keep it above the level of the sand. Sometimes the piezometer is placed in a sand-filled canvas bag, which serves two purposes: it creates a sand intake zone and it serves as a weight to help sink the piezometer and tubing in water filled boreholes.
3. Lower the piezometer to its intended depth. You will have to add weight to the piezometer to lower it into a water filled borehole.
4. Tremie sand around the piezometer, again pulling the casing to keep it above the level of the sand. Continue until at least six inches (150 mm) of sand has been placed above the piezometer.
5. Place a bentonite seal above the intake zone, using bentonite chips. A typical seal is at least 1 foot thick, but refer to project specifications for the required length. Again, be sure to pull the casing up above the level of the bentonite. Drop chips in slowly to ensure proper placement of the seal and to avoid bridging. The bentonite seal typically requires 2 to 3 hours to set up, but refer to your bentonite instructions for exact times. Keep the borehole filled with water to fully hydrate the bentonite and prevent it from drawing water from the surrounding soil.
6. Backfill with a bentonite-cement grout.
7. If the piezometer is checked at this stage, readings will not be valid because the ground has been disturbed by drilling and backfill. Recovery time depends on the permeability of the surrounding soil, the size of the sand intake zone, and the size of the seal. Take readings periodically to determine when recovery has occurred, and then obtain your datum reading.
8. Terminate the installation as specified. It is important to terminate the tubing above ground level and keep quick connects clean and dry. Protect the installation from construction traffic and mark its location with a stake.

Borehole Installation (Grout-In Method)

This is still an “experimental” procedure.

1. Drill the borehole below the required depth of the piezometer. Flush the borehole with water or biodegradable drilling mud.
2. Lower the piezometer to its intended depth. You will have to add weight to the piezometer to lower it into a water filled borehole.
3. Back-fill the borehole with grout. Use either of the mixtures below as a starting point for your grout mix. Mix cement with water first, and then add the bentonite. Adjust the amount of bentonite to produce a grout with the consistency of heavy cream. If the grout is too thin, the solids and the water will separate. If the grout is too thick, it will be difficult to pump.

Grout Mix for Hard and Medium Soils		
Materials	Weight	Ratio by Weight
Portland cement	94 lb (1 bag)	1
Bentonite	25 lb (as required)	0.3
Water	30 gallons	2.5
Grout Mix for Soft Soils		
Materials	Weight	Ratio by Weight
Portland cement	94 lb (1 bag)	1
Bentonite	39 lb (as required)	0.4
Water	75 gallons	6.6

4. Readings taken immediately after installation will be high, but will decrease as the grout cures. Datum readings can be taken hours to days after installation, depending on the permeability of the soil. The lag time caused by the grout itself is measured in minutes.
5. Terminate the installation as specified, keeping ends of tubing clean and dry. Protect the installation from construction traffic and mark its location with a stake.

Embankment Installation

1. For direct contact between filter and soil, the piezometer is placed in a preformed hole. Check project specifications for the required procedure.
2. Place a bentonite seal or backfill with select fill material.
3. Protect tubing on top and bottom with hand-compacted layers of fine embankment materials. To compact the lift material immediately above this protective layer of fines, use light-weight power tamping or rubber-tired equipment, but avoid using heavy vibratory rollers or sheepsfoot rollers until there is a lift of at least 18 inches (0.5 meters) above the tubing.
4. Avoid making tight bends in the tubing. If the tubing path changes direction, use extra tubing at the turn. Avoid crossing tubing. If tubing must cross, place a layer of fine fill material between the tubing. Some specifications require that extra tubing be snaked in the trench to accommodate settlement or lateral deformation of the embankment.
5. Build water stops as specified.
6. Terminate tubing as specified. Keep ends of tubing clean and dry. Protect the installation from construction traffic and mark its location with a stake

Installation in a Monitoring Well

1. Lower the piezometer into the well and position it at the specified depth or just below the maximum expected drawdown. You must attach a weight to the piezometer to counter buoyancy.
2. Secure the ends of the tubing above ground level. Keep ends clean and dry.

Reading the Piezometer

Operating Principle

The single moving part in a pneumatic transducer is a flexible rubber diaphragm. Water pressure acts on one side of the diaphragm and gas pressure acts on the other.

When a reading is required, the operator connects a pneumatic indicator to the tubing from the transducer and sends compressed nitrogen gas from the indicator down the input tube.

Gas pressure increases inside the transducer. Finally, when the pressure of the gas exceeds the pressure of the water, the diaphragm is forced outward, away from the vent tube. Excess gas then escapes through the vent tube to the surface.

On detecting a return flow of gas at the surface, the operator turns off the flow of gas into the transducer. Gas continues to flow out through the vent tube, and pressure inside the transducer decreases until water pressure forces the diaphragm to its original position, sealing off the vent tube and preventing further escape of gas.

At this point, there is a balance between the pressure of gas inside the transducer and the pressure of water outside. The operator then notes the reading on the indicator's pressure gauge.

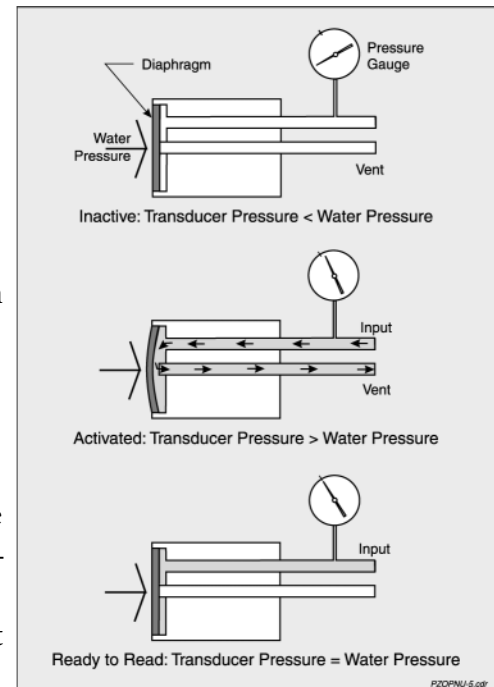

Two Reading Methods

There are two commonly used methods for reading pneumatic piezometers and other types of pneumatic transducers: reading after shut-off and reading with flow.

Reading after Shut-Off

This method is the normal way to read twin-tube transducers. The transducer is activated by a flow of gas. Then, when a return flow is detected, the gas is shut off.

Using the 256 indicator: Turn the flow control valve to the On position to activate the transducer. The reading on the pressure gauge goes up. Then, when you detect a return flow of gas from the vent tube, turn the flow control valve to the Off position. The reading on the pressure gauge drops and finally stabilizes. Tap the gauge and write down the reading.

The key to reliable readings: Allow sufficient time for excess gas to vent from the transducer after the flow of gas is shut off.

Reading with Flow

This method is used with triple-tube transducers and is sometimes suitable for twin-tube transducers. The transducer is activated by a flow of gas. Then, when a return flow is detected, the flow rate is slowed.

Using the 256 indicator: Turn the flow control valve to the On position to activate the transducer. The reading on the pressure gauge goes up. Then, when you detect a return flow of gas, set the flow rate valve so that the flowmeter shows 30mm on its scale. This is equivalent to 47 cc/m or 0.1 SCFH. Monitor the flowmeter to ensure that the flow rate remains constant. When the reading on the pressure gauge stabilizes, tap the gauge and write down the reading.

The key to reliable readings: Accurate control of the flow rate, which requires a flowmeter.

Standard Reading Method

Reading after shut-off is the standard method for reading twin-tube piezometers. The instructions below are for Slope Indicator's 256 Indicator, but operation of other indicators is similar.

Setting Up

1. Before leaving for the site, check that you have enough gas in the tank. The tank pressure should be higher than 35 bar or 500 psi. Refill the tank, if necessary.
2. Also check that you have the jumper tubing supplied with your indicator. The jumper serves as an extension of the tubing from the transducer and is used when connectors are hard to reach.
3. Check the regulated pressure. As a general rule, it should be no higher than the pressure rating of your pressure gauge. Turn the knob clockwise to increase the pressure or counter-clockwise to decrease the pressure.
4. Turn the tank control valve to the On position to supply gas to the indicator. You can leave the valve in this position most of the time.
5. Zero the pressure gauge before you take readings. As a general rule, you should zero the pressure gauge on site. t

Connect Tubing to the Indicator

1. The twin-tubing from the transducer contains a black tube and a clear (white) tube.
2. The black tube is terminated with a quick-connect plug. Connect the black tube to the indicator's transducer socket. If the plug is mounted in a panel, use the jumper to connect between panel-mounted plug and the indicator.

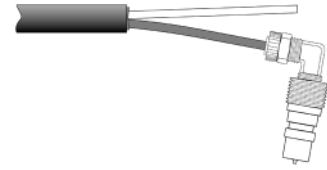

3. The clear tube is the vent tube. The vent tube may be protected by a dust cap. Remove the cap before you activate the transducer or you may be surprised by a pop when returning gas blows it off. Connect the vent tube to the return flow indicator or place it in a clear, water-filled bottle, as described below.

Tip: If you place the end of the vent tube in a water-filled bottle, the return flow of gas will be visible as bubbles. When the bubbles stop or slow significantly, you can be sure that excess gas has escaped and the transducer is ready to read.

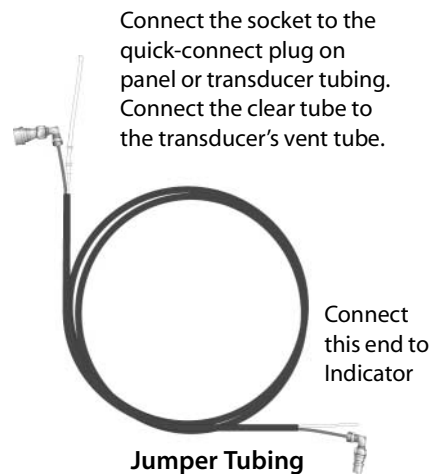

Activating the Piezometer

1. Turn the flow control valve to the On position.
2. If necessary, adjust the flow rate with the flow rate valve. The reading on the pressure gauge should increase at about 1 psi per second (slightly faster than 0.05 bar per second).

Tip: Transducers with longer lengths of tubing take more time to activate and read. Increasing the flow rate will not significantly reduce this time. In fact, a faster flow rate may result in a longer wait for the reading to stabilize because additional gas must flow through the transducer.

Reading the Piezometer

1. Wait for a return flow of gas from the vent tube. If you are using a bubble bottle, watch for bubbles.
2. When you detect a return flow, turn the flow control valve to the Off position.
3. Wait for the pressure reading to stabilize. If you are using a bubble bottle, wait for the bubble rate to slow to about 2 bubbles per second. This rate of flow is insignificant to the accuracy of the reading.
4. Tap the gauge and write down the reading.

Verifying the Reading

It is a good practice to verify the reading.

1. Turn the flow control valve On.
2. Wait for a return flow, then turn the flow control valve Off.
3. Wait for the reading to stabilize and compare it to the first reading. Repeat this process until you have repeatable readings.

Shutting Down

1. Disconnect the tubing from the indicator and replace any dust caps.
2. If this is the last reading for the day, turn the tank control valve Off, turn the flow control to Vent, and turn the regulator knob counter-clockwise to reduce the regulated pressure to zero.

Reading Twin-Tube Transducers with Flow

This is an alternative method for reading twin-tube piezometers. The instructions below are for Slope Indicator's 256 Indicator, but operation of other indicators is similar.

Setting Up

1. Before leaving for the site, check that you have enough gas in the tank. The tank pressure should be higher than 35 bar or 500 psi. Refill the tank, if necessary.
2. Check the regulated pressure. As a general rule, it should be no higher than the pressure rating of your pressure gauge. Turn the knob clockwise to increase the pressure or counter-clockwise to decrease the pressure.
3. Turn the tank control valve to the On position to supply gas to the indicator. You can leave the valve in this position most of the time.
4. Check that you have the jumper tubing. It serves as an extension of the tubing from the transducer and is used when connectors are hard to reach.
5. As a general rule, you should zero the pressure gauge on site.

Connect Tubing to the Indicator

1. The twin-tubing from the transducer contains a black tube and a clear (whitish) tube.

2. The black tube is terminated with a quick-connect plug. Connect the black tube to the indicator's transducer socket. If the plug is mounted in a panel, use the jumper to connect between panel-mounted plug and the indicator.

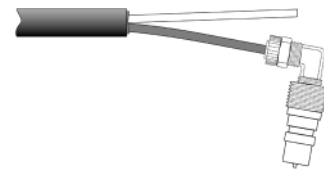

3. The clear tube is the vent tube. The vent tube may be protected by a dust cap. Remove the cap before you activate the transducer or you may be surprised by a pop when returning gas blows it off. Connect the vent tube to the return flow indicator or place it in a clear, water-filled bottle, as described below.

Tip: If you place the end of the vent tube in a water-filled bottle, the return flow of gas will be visible as bubbles. When the bubbles stop or slow significantly, you can be sure that excess gas has escaped and the transducer is ready to read.

Activating the Piezometer

1. Turn the flow control valve to the On position.
2. If necessary, adjust the flow rate with the flow rate valve. The reading on the pressure gauge should increase at about 1 psi per second (slightly faster than 0.05 bar per second).

Tip: Transducers with longer lengths of tubing take more time to activate and read. Increasing the flow rate will not significantly reduce this time. In fact, a faster flow rate may result in a longer wait for the reading to stabilize because additional gas must flow through the transducer.

Reading the Piezometer

1. Wait for a return flow of gas from the vent tube. If you are using a bubble bottle, watch for bubbles.
2. Then, when you detect a return flow of gas, set the flow rate valve to about 47 cc/m or 0.1 SCFH. On the 256 indicator, the flowmeter should show about 30mm.
3. Wait for the pressure reading to stabilize. With 500 feet of tubing, this takes about 90 seconds.
4. Tap the gauge and write down the reading.

Verifying the Reading

It is a good practice to verify the reading.

1. Briefly turn the flow control valve to the Vent position. The purpose is to change the reading on the pressure gauge.
2. Wait for the reading to stabilize and compare it to the first reading. Repeat this process until you have repeatable readings.

Shutting Down

1. Disconnect the tubing from the indicator and replace any dust caps. Pressure remaining in the transducer tubing helps keep out water.
2. If this is the last reading for the day, turn the tank control valve Off, turn the flow control to Vent, and turn the regulator knob counter-clockwise to reduce the regulated pressure to zero.

Troubleshooting

Problem	Possible Cause	Solution
Pressure reading too low	Supply pressure has dropped too low	Check gas supply
	Indicator circuits are venting	Turn control valve to halt venting
	Loose connection or damaged O-ring in quick-connect socket	Inspect O-ring and replace if necessary Clean and reconnect fitting
	Damaged tubing or bad splice	Splice tubing if accessible
Pressure reading too high or continues to increase	Input tube or vent tube is pinched or plugged	Check clear tube for blockages first, then check for return flow Check both tubes for pinching
	Piezometer is being activated at too high a flow rate	Reduce flow rate
	Quick-connect fitting is plugged	Clean and reconnect fitting
Erratic readings	Moisture or dirt in tubing	Purge tubing
	Damaged tubing	Replace tubing if accessible

How to Purge Tubing

1. Close all indicator valves.
2. Connect input tube (black) to input socket.
3. Check that vent tube is open to atmosphere.
4. Adjust supply pressure between 50 and 100 psi (345 to 690 kPa or 35 to 70 m H₂O).
5. Pressurize piezometer.
6. Maintain gas flow to evaporate water or force it out of vent tube (10 to 30 minutes, depending on length of tubing).
7. Shut off gas supply.
8. Check reading. Repeat purge operation if reading is still erratic.

How to Splice Tubing

Splice Kit The 51401723 Splice Kit contains the necessary materials to join two lengths of twin pneumatic tubing.

- Instructions**
1. Remove approximately 75 mm (3 inches) of tubing jacket from end of each length of tubing. Check that there are no nicks or cuts on tubing.

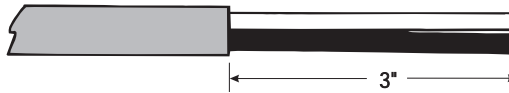

2. Lay out tubing and cut individual tubes so that unions will be staggered when tubes are joined (tubes must be cut square).

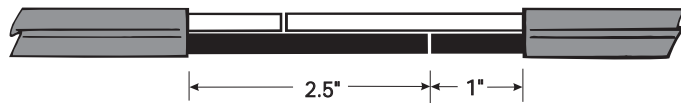

3. Join tubes with unions provided in splice kit. Make sure tubing is fully inserted into unions. Finger tighten nuts, then apply one full turn with wrench.



4. Tug on tubing to check that splices are good.
5. Wrap joint with mastic pad. Then wrap sealing tape over mastic pad. Stretch tape up to 50 percent of length when applying. Try to cover at least 2 inches (50 mm) beyond ends of mastic pad.

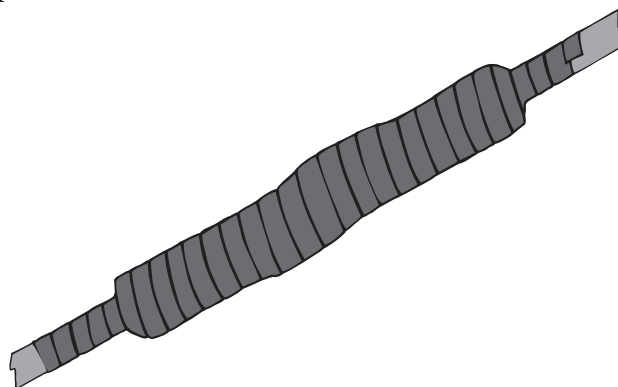

Connecting Tubing to 1.5-inch Piezometers

How to Connect Tubing This procedure describes how to connect tubing to 1.5-inch pneumatic piezometers.

- Tools and Materials**
- Tubing
 - Two 7/16-inch wrenches
 - O-ring lubricant or silicone grease
 - ABS cement
 - Potting resin

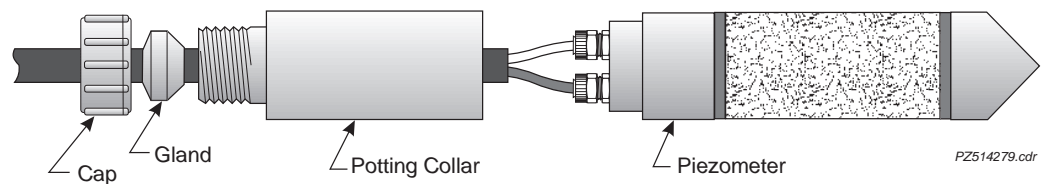

- Step 1: Remove Filter**
1. Remove filter to avoid damaging it while attaching tubing. Unscrew filter retainer (pointed end of piezometer) and remove filter. Keep filter clean and free from grease, mud, and bentonite.

Step 2: Prepare Tubing

2. Unscrew cap on potting collar to expose rubber gland.
3. Strip jacket and jacket liner to expose about 2 inches (50 mm) of twin tubing. Be careful not to cut into tubing.
4. Trim each tube to 1.5 inches (38 mm).
5. Slide cap, gland, and potting collar onto tubing. Check that gland is in same orientation as shown in drawing on previous page.

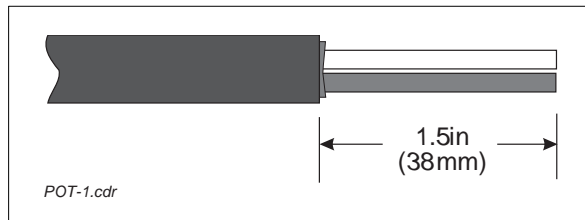

Step 2: Attach Compression Fittings

1. Before you can attach tubing to piezometer, you must crimp ferrule to tubing to ensure a good seal.
2. Remove compression fitting nuts from piezometer fittings.
3. Slide one nut over each tube, then push tubes into fittings on piezometer body. Connect the black tube to the input fitting (marked) and the clear tube to the other fitting (unmarked).
4. This step compresses ferrule inside nut around tubing. Make sure that tube is seated in fitting. Finger tighten nut. Then use one wrench to keep piezometer fitting from turning and use other wrench to tighten nut another 3/4 turn.
5. Repeat previous step for other tube, then tug on tubing to check connections.

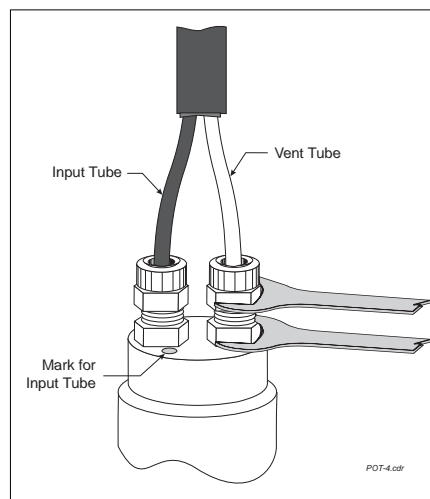

Step 3: Potting

1. Use ABS cement to attach potting collar to piezometer body. Allow 15 to 20 minutes for cement to harden.
2. Mix potting resin. Avoid skin contact with resin. Hold tubing to one side. Pour in resin to 1/2-inch (10 mm) below top of collar. Allow resin to cure overnight.
3. Apply a light coat of silicone grease or O-ring lubricant to gland. This will let you tighten cap without twisting tubing.
4. Fit gland into top of potting collar. Hold potting collar and piezometer body (not filter) and finger tighten cap. Do not twist tubing.

