

EL IPI with Serial Mux 56804599

Copyright ©2001 Slope Indicator Company. All Rights Reserved.

This equipment should be installed, maintained, and operated by technically qualified personnel. Any errors or omissions in data, or the interpretation of data, are not the responsibility of Slope Indicator Company. The information herein is subject to change without notification.

This document contains information that is proprietary to Slope Indicator company and is subject to return upon request. It is transmitted for the sole purpose of aiding the transaction of business between Slope Indicator Company and the recipient. All information, data, designs, and drawings contained herein are proprietary to and the property of Slope Indicator Company, and may not be reproduced or copied in any form, by photocopy or any other means, including disclosure to outside parties, directly or indirectly, without permission in writing from Slope Indicator Company.

SLOPE INDICATOR

12123 Harbour Reach Drive
Mukilteo, Washington, USA, 98275
Tel: 425-493-6200 Fax: 425-493-6250
E-mail: solutions@slope.com
Website: www.slopeindicator.com

Contents

Introduction.....	1
Pre-Assembly	4
Installation	5
Data Logging.....	9
Data Reduction.....	10

Introduction

In-Place Inclinerometers

The in-place inclinometer system consists of inclinometer casing and a string of electrolytic inclinometer sensors. The inclinometer casing is installed in a vertical borehole that passes through a suspected zone of movement. The sensors, each connected to the next by a pivot point, are positioned inside the casing to span the zone of movement. When ground movement occurs, casing is displaced, causing a change in the tilt of the sensors inside.

The sensors measure tilt, the angle of inclination from vertical. The tilt measurement is converted to lateral deviation using the formula $L \sin \theta$, where L is the gauge length of the sensor and θ is the tilt.

Displacement, the lateral distance the casing has moved, is calculated by finding the difference between the current and initial deviations.

In most applications, sensors are connected to a data acquisition system that continuously monitors movements and can trigger an alarm when it detects a change, or a rate of change, that exceeds a preset value.

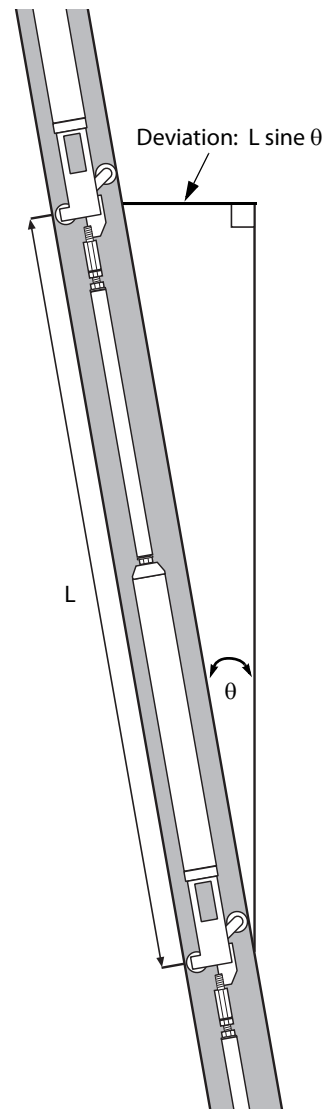

Components of IPI Sensor



Gauge tubing: Completes gauge length of sensor.

Top clamp: Used to suspend sensors from top of casing.



Tubing clamp: Connects gauge tubing to the sensor body.

Coupling: Connects lengths of placement tubing.

Placement tubing: (not shown) suspends sensors from top of inclinometer casing.

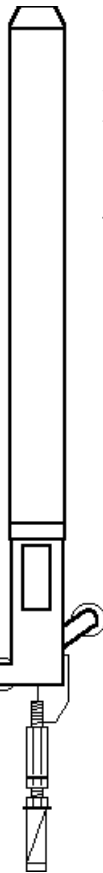

IPI sensor: Includes wheel assembly and top and bottom tubing clamps. Tapered end of sensor is the top.

Two cables exit the top. One is connected to the sensor below, the other is connected to the sensor above.

In-line wheel assembly: Used to terminate gauge length of top sensor.

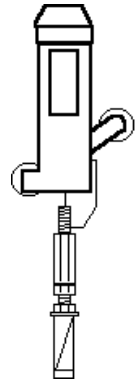

Swivel clamp: Locks the swivel on the bottom wheel assembly.

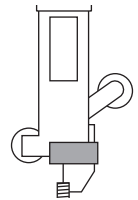

Tubing clamp: Connects the sensor to the gauge tubing of another sensor. Supplied with the sensor.

Gauge Tubing

Gauge tubing may be pre-cut and supplied with the sensors. If gauge tubing is not supplied, check project specifications for required gauge length, and then follow the instructions below:

1. Choose stainless tubing that can accept tubing clamps. The standard tubing clamps have a minimum ID of 15.6 mm (0.615 inch) and expand to a maximum ID of 17.4 mm (0.685 inch).
2. Measure and mark the gauge tubing for the proper length: tubing length = total gauge length – 550 mm (21.625 inch). For example, you would cut tubing lengths of 1450 mm for a total gauge length of 2 meters.
3. Cut and deburr the gauge tubing. Check that tubing clamps fit inside.

Placement Tubing

Placement tubing is used to suspend the string of sensors from the top of the inclinometer casing. Use the coupling shown on previous page to join lengths of placement tubing. Use in-line wheel assembly if placement tubing must be articulated. If placement tubing is not supplied with the sensors, follow the instructions below:

1. Choose stainless tubing that can accept tubing clamps and couplings. The standard tubing clamps have a minimum ID of 15.6 mm (0.615 inch) and expand to a maximum ID of 17.4 mm (0.685 inch).
2. Deburr the gauge tubing and check that tubing clamps fit inside.

Pre-Assembly

Identify Sensors

1. Sensors are pre-wired into strings at the factory. Each string is packed into its own box along with calibration records for each sensor.
2. Verify the serial number and position of each sensor in the string. The bottom sensor has a swivel clamp attached to its wheels, as shown.
3. If possible, connect the sensor string to a data logger and test that the system is working properly. See the section on Data Logging for details.

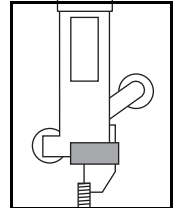

Attach Gauge Tubing to Each Sensor

Remove the tubing clamp from the top of each sensor. Insert it into the gauge tubing. Tighten well. Then screw gauge tubing into sensor body. Body and tubing should form a rigid unit.

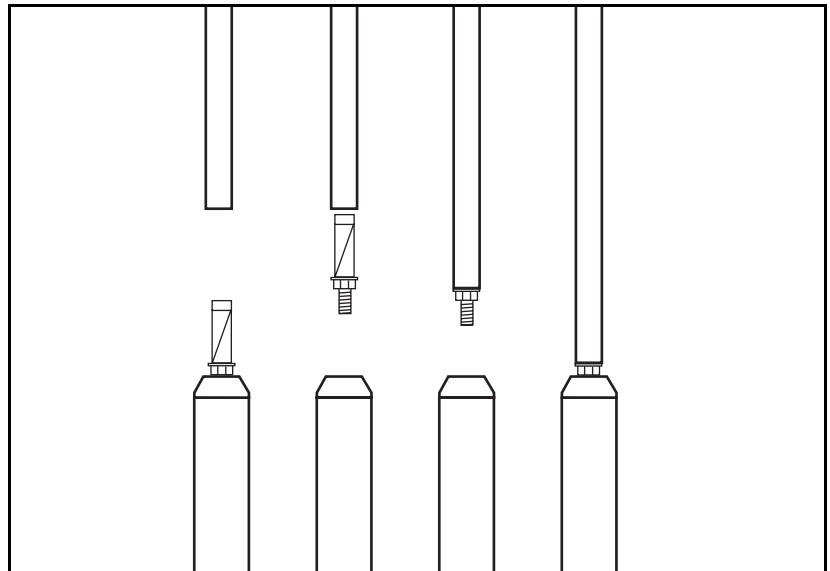

Installation

Overview

Installation involves connecting each sensor to the next as the sensor string is lowered into the casing.

1. Align the wheels of the first sensor with the preferred set of grooves. The fixed wheel should point to the direction of movement. With horizontal installations, the fixed wheel should point downwards.
2. Lower the sensor into the casing. Keep the top of the gauge tube accessible. With horizontal installations, push the sensor into the casing.
3. Connect the next sensor to the gauge tubing of the downhole sensor. Then lower (or push) it into the casing.
4. Continue connecting sensors until the string is complete.
5. Connect the final wheel assembly and placement tubing.
6. Suspend the sensor string from the top clamp. Note that horizontal sensors will be in compression, since you have been pushing them into the borehole. If possible, pull on the sensor string to put it into tension. In some cases, this will not be practical.

Required Tools

- Rope or cable attached to bottom sensor to (1) prevent loss of sensors down hole, and (2) control the position of the string during installation. A winch may be useful if there are many sensors. With horizontal installations, this is probably not a concern.
- Vice grips (clamping pliers) for holding gauge tubing while connecting adjacent sensors.
- Allen wrench for securing top clamp.
- Cable ties and vinyl tape for securing cable to gauge tubing.

Preparations

1. Attach gauge tubing to each sensor, as explained on the previous page.
2. Lay out sensors close to the borehole.

Install Bottom Sensor

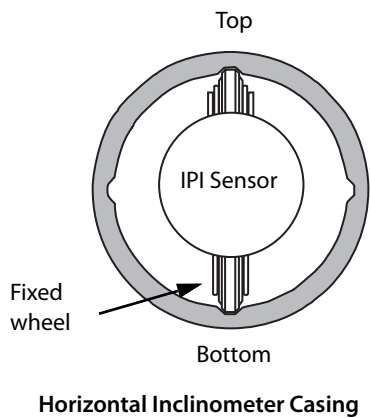
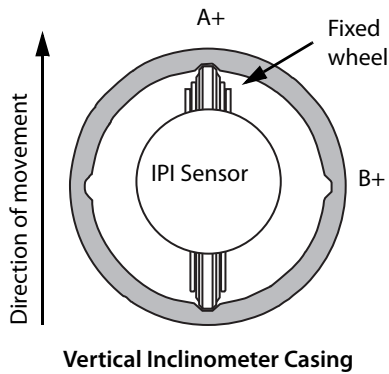

1. Attach safety line (nylon or wire rope) to bottom sensor.
2. Align the fixed wheel with the preferred set of grooves:
 - In vertical installations, casing is oriented so that one set of grooves is aligned in the direction of expected movement. Align the fixed wheel of the sensor toward the direction of movement, as shown in the drawing at left.
 - In horizontal installations, casing is oriented so that one set of grooves is aligned to vertical. Insert the fixed wheel of the sensor in the bottom groove, as shown at left.
3. Lower sensor into casing.
4. Use vice grips to clamp top of gauge tubing. Now the next sensor can be installed.

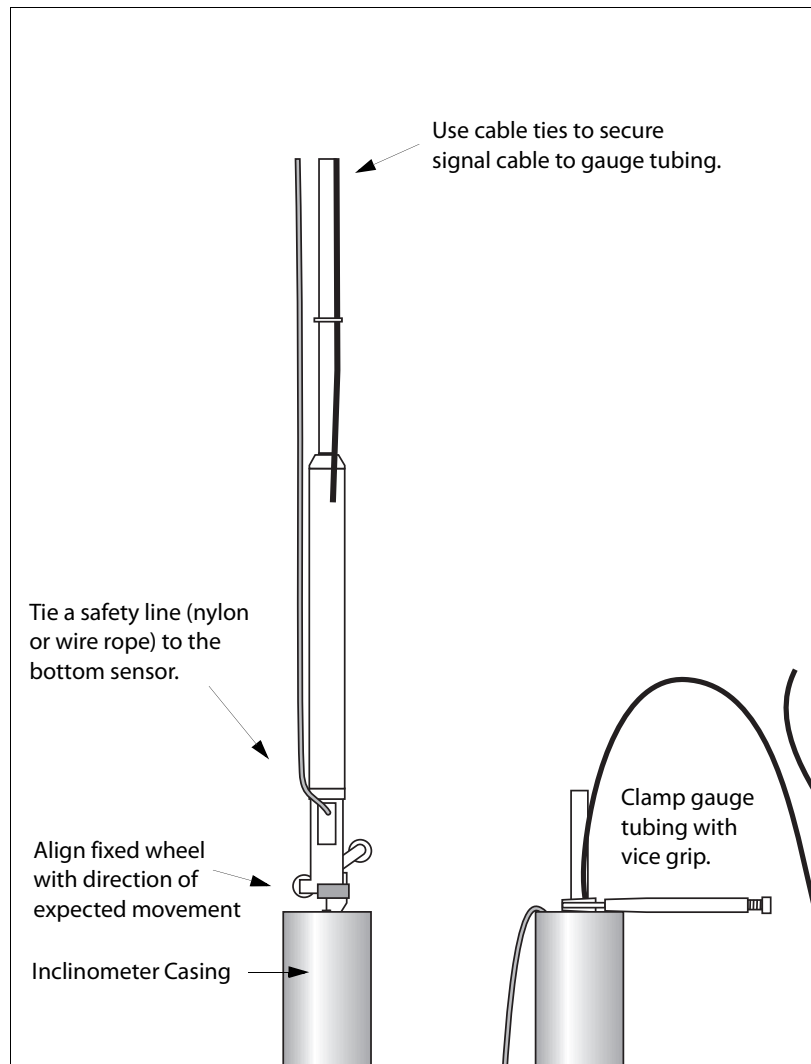

Install Next Sensor

1. Connect next sensor to the gauge tubing of the sensor below, as shown in the drawing. Continue adding sensors until the sensor string is complete. Keep the following points in mind:
 - Do not allow the installed sensor to twist in the casing when you tighten the connection. Twisting can damage the wheels or pop them out of the grooves.
 - When you lower the sensor into the casing, check that the fixed wheel is aligned in the proper direction.
 - Use cable ties to secure cables to gauge tubing.

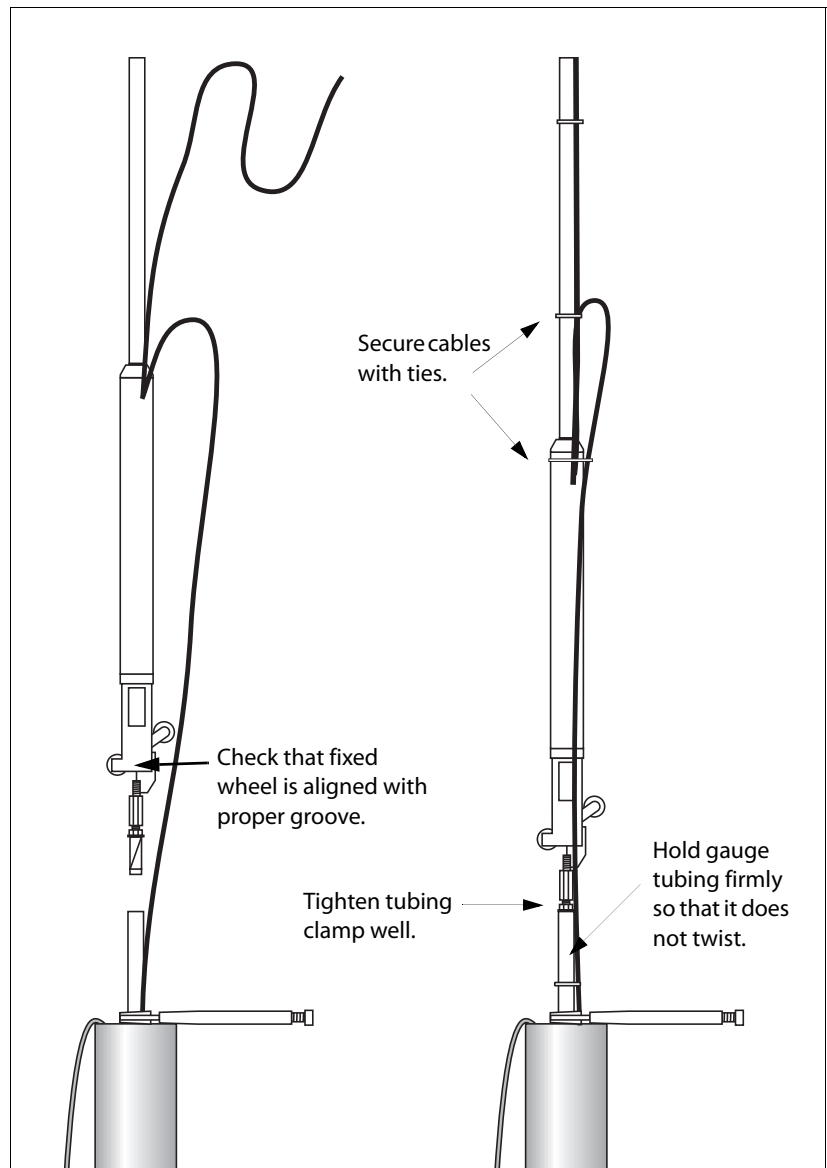

Install In-Line Wheel, Placement Tubing, and Top Clamp

The in-line wheel assembly terminates the gauge length of the last sensor in the string. Placement tubing allows the string to be suspended deeper in the casing. The top clamp holds the placement tubing.

1. Attach wheel assembly to gauge tubing of last sensor.
2. Check that placement tubing is the right length. Then attach to wheel assembly.
3. Finally, suspend the entire sensor string from the top clamp. The top clamp has a split collar. Loosen the screws, slide the collar over the placement tubing or gauge tubing, and then tighten the screws

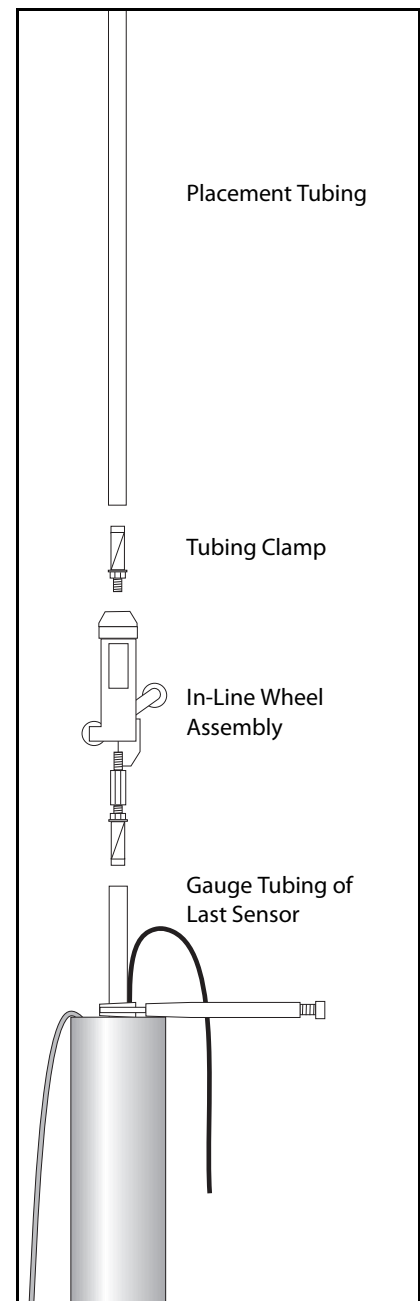
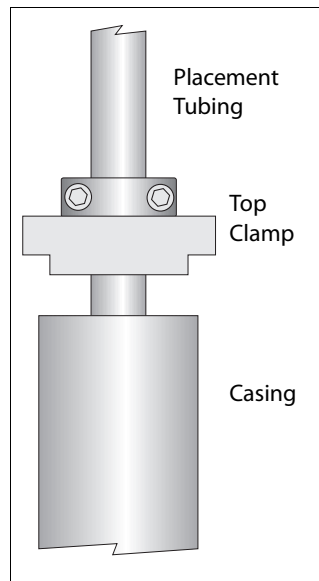

DataLogging

Wiring Diagram for CR10X

The wiring diagram below shows how to connect signal cable to a CR10X data logger.

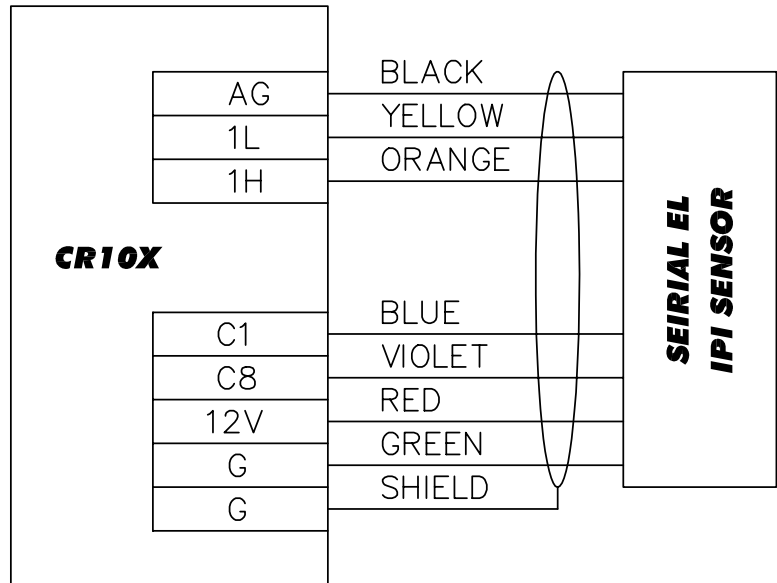

Sample Program

A sample monitoring program is available at Slope Indicator's website. Go to www.slopeindicator.com - support- tech notes. Look at the data logger technotes. You'll see a link for sample programs.

Data Reduction

Introduction Data reduction is usually automated because it involves a large number of readings and a large number of calculations.

Here, we explain how to use the sensor calibration record and provide an example of converting a single reading from voltage to mm of deviation.

Once you have deviations, you can calculate displacements (movements) by subtracting the initial deviation from the current deviation.

Calibration Record A calibration record is provided with each EL IPI sensor. Note that calibrations are unique for each sensor, so use sensor serial numbers to match sensors with their calibrations.

The sensor calibration record lists three sets of factors for each axis of the sensor and one factor for the temperature sensor. The table at right shows factors for sensor serial number 10001. Your sensors will have different factors.

C0	-7.0311
C1	73.878
C2	-0.22265
C3	-0.33079
C4	0.019426
C5	0.020221
S0	1
S1	0.00059828
S2	0.0000068117
F0	00012125
F1	0.016273
F2	0.00096919
Toffset	0.19
Tnom	12

C0 to C5: Use these factors to convert a reading in volts to mm per meter of gauge length.

S0 to S2: Use these factors to adjust the mm/m value above for temperature-related changes in sensor sensitivity.

F0 to F2: Use these factors to adjust the mm/meter value for temperature-related changes in the offset of the sensor.

Toffset: Use this factor in the equation to convert a thermistor reading in volts to degrees C.

Tnom: Tnom is normally 12 degrees C. However, the value shown on the sensor calibration record may be higher or lower if your sensors were calibrated over a custom range of temperatures.

Applying Calibration Factors

Suppose you obtain a reading of 570 millivolts (0.57V) from sensor 10001, which has a gauge length of 2 meters. How do you convert the voltage reading to mm of deviation?

Converting sensor reading to mm per meter

Apply the C factors to the voltage reading as shown below. EL represents a reading in volts. C5 through C0 are factors that appear on the sensor calibration record. The result of the calculation is a value in mm per meter.

$$\text{mm/meter} = C5 \cdot EL^5 + C4 \cdot EL^4 + C3 \cdot EL^3 + C2 \cdot EL^2 + C1 \cdot EL + C0$$

	C Factor	EL Reading	Value
C0	-7.0311		-70311
C1	73.878	0.57	42.11046
C2	-0.22265	0.57^2	-0.07234
C3	-0.33079	0.57^3	-0.06126
C4	0.19426	0.57^4	0.002051
C5	0.020221	0.57^5	0.001217
mm per meter deviation =			34.94903

Calculating deviation in mm

To calculate deviation for a particular gauge, multiply the mm/meter value by the gauge length of the sensor.

$$\text{deviation in mm} = \text{mm/meter value} \cdot \text{gauge length of sensor}$$

In this example, the gauge length is 2 meters, so the deviation would be about 70 mm.

Converting thermistor readings to degrees C.

If you are using a CR10 data logger, the thermistor reading appears in volts. To convert the volt reading to degrees C, use the equation below. The Toffset value can be found on the sensor calibration sheet.

$$\text{DegC} = (58.6752 \cdot \text{ET}^5 - 278.839 \cdot \text{ET}^4 + 509.188 \cdot \text{ET}^3 - 449.099 \cdot \text{ET}^2 + 233.754 \cdot \text{ET} - 48.4917) - \text{Toffset}$$

Correcting for Temperature

Changes in temperature affect both the sensitivity and the offset of the sensor. In the instructions below, the sensitivity temperature correction is called SENSTC. The offset temperature correction is called OFFSTC.

1. Find the change in temperature from Tnom, which is a value on the sensor calibration sheet.

$$\text{DeltaT} = \text{DegC} - \text{Tnom}$$

For our example, DegC is 19.3 and Tnom is 12 degrees C, so DeltaT, the change in temperature, is 7.3 degrees C.

2. Calculate the sensitivity correction:

$$\text{SENSTC} = \text{S2} \cdot \text{DeltaT}^2 + \text{S1} \cdot \text{DeltaT} + \text{S0}$$

	S Factor	DeltaT	Value
S0	1		1
S1	0.00059828	7.3	0.004367
S2	0.0000068117	7.3 ²	0.000363
SENSTC =			1.00473

3. Calculate the offset correction:

$$\text{OFFSTC} = \text{F2} \cdot \text{DeltaT}^2 + \text{F1} \cdot \text{DeltaT} + \text{F0}$$

	F Factor	DeltaT	Value
F0	0.00012125		.000121
F1	0.016273	7.3	0.118793
F2	0.00096919	7.3 ²	0.051648
OFFSTC =			0.170562

4. Apply the corrections:

$$\begin{aligned} \text{corrected value} &= (\text{mm/meter value} \cdot \text{SENSTC}) + \text{OFFSTC} \\ &= (34.94903 \cdot 1.00473) + 0.170562 \\ &= 35.28491 \end{aligned}$$

**Direction of Movement
for Vertical IPIs**

Displacement data from vertical inclinometers are usually referenced to the bottom of the casing, as shown below.

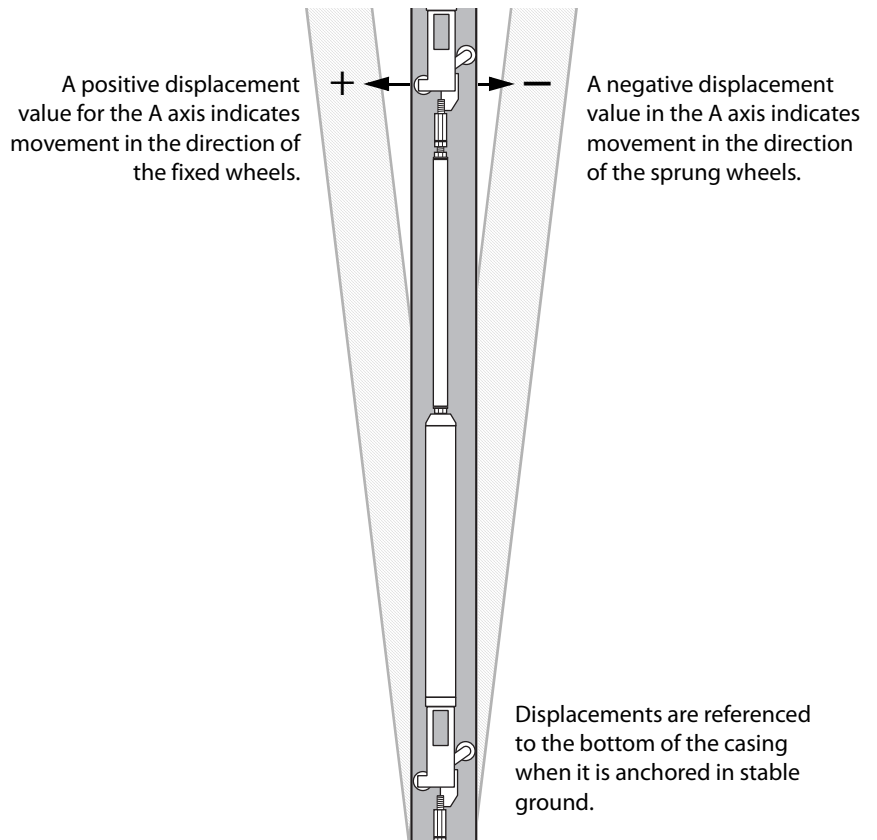

**Direction of Movement
for Vertical IPIs**

The drawing below is the top of the sensor. Movement is referenced to the bottom of the sensor, as in the drawing above.

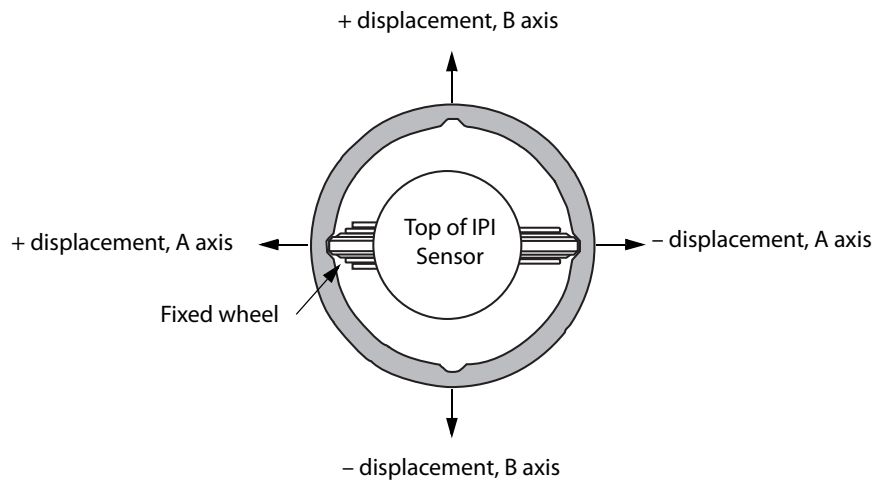

**Direction of Movement
Horizontal Sensor**

Horizontal inclinometer casing is installed with one set of grooves oriented to the vertical plane. The sensors are then installed with the fixed wheel in the bottom groove.

Far-End Reference

The inaccessible (far) end of the casing is used as reference when it is anchored in stable ground:

A negative displacement value indicates movement in the direction of the sprung wheels.

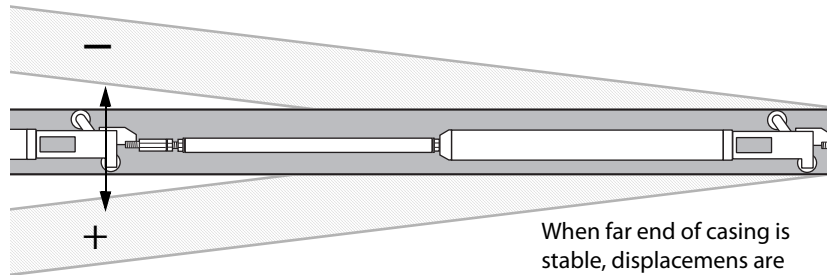

A positive displacement value indicates movement in the direction of the fixed wheels.

When far end of casing is stable, displacements are referenced to the far end.

Near-End Reference

The accessible (near) end of the casing is used as reference when the far end is not stable. If the near end is subject to movement, its position should be recorded at the same time as the sensors are read:

A positive displacement value indicates movement in the direction of the sprung wheel.

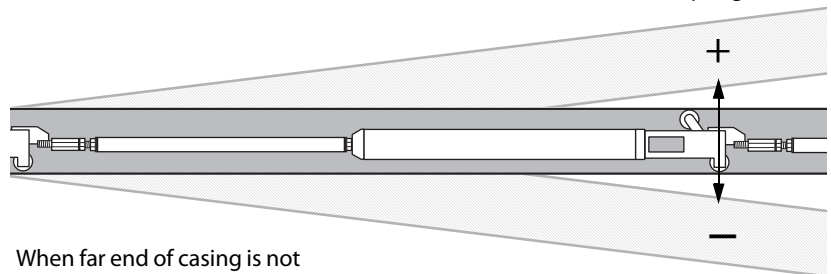

When far end of casing is not stable, displacements are referenced to the near end.

A negative displacement value indicates movement in the direction of the fixed wheel.