

EL Beam Sensors

Standard & 250 mV SC Versions

56801399

Copyright ©2002 Slope Indicator Company. All Rights Reserved.

This equipment should be installed, maintained, and operated by technically qualified personnel. Any errors or omissions in data, or the interpretation of data, are not the responsibility of Slope Indicator Company. The information herein is subject to change without notification.

This document contains information that is proprietary to Slope Indicator company and is subject to return upon request. It is transmitted for the sole purpose of aiding the transaction of business between Slope Indicator Company and the recipient. All information, data, designs, and drawings contained herein are proprietary to and the property of Slope Indicator Company, and may not be reproduced or copied in any form, by photocopy or any other means, including disclosure to outside parties, directly or indirectly, without permission in writing from Slope Indicator Company.

SLOPE INDICATOR

12123 Harbour Reach Drive
Mukilteo, Washington, USA, 98275
Tel: 425-493-6200 Fax: 425-493-6250
E-mail: solutions@slope.com
Website: www.slopeindicator.com

Contents

Introduction	1
Installing Horizontal Beam Sensors .	3
Installing Vertical Beam Sensors	7
Zero Adjusting Standard Sensors ..	11
Reading Standard Sensors.....	15
Zero Adjusting SC Sensors.....	16
Reading SC Sensors	20
Data Reduction	23

Introduction

Operating Principle

EL beam sensors monitor rotation and differential movement in structures. Horizontal beams sensors are used to monitor settlement and heave. Vertical beams monitor lateral displacements. Linked end to end, beam sensors can monitor differential movements.

The beam sensor consists of an electrolytic tilt sensor attached to a rigid metal beam. The tilt sensor is a precision bubble-level that is sensed electrically as a resistance bridge. The bridge circuit outputs a voltage proportional to the tilt of the sensor.

The beam, which is typically one to two meters long, is mounted on anchor bolts that are set into the structure. Movement of the structure changes the tilt of the beam and the output of the tilt sensor.

The voltage reading from the tilt sensor is converted to a reading in mm per meter. Displacement is calculated by subtracting the initial reading from the current reading.

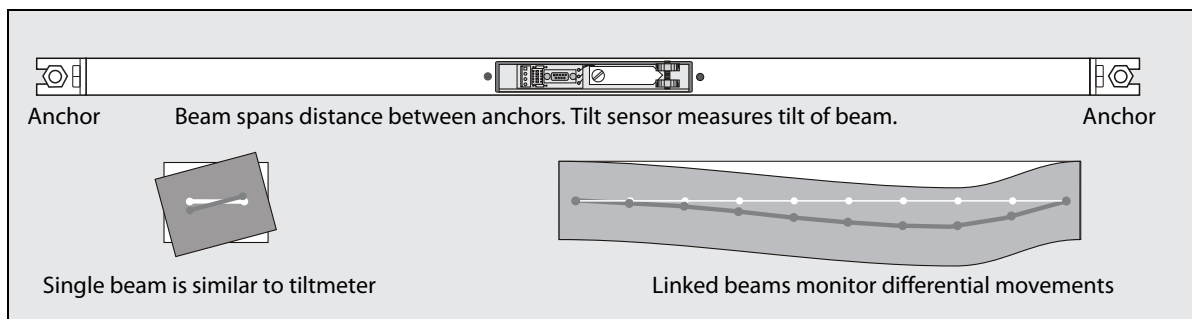

Beam Sensor Components

Beam sensor components include a beam with end brackets, an anchor kit, an EL tilt sensor, and a terminal board.

Beams

Beams are square section aluminum beams supplied in gauge lengths up to 2 meters. End brackets are included with each beam. The horizontal beam has a built-in compartment and cover for the tilt sensor. The vertical beam has no compartment, since the sensor is supplied with a separate housing that clamps onto the beam.

Each beam is supplied with end-brackets that can be secured directly to wall anchors. This method of installation is satisfactory with solitary beams that only rotation. However, if beams are linked, or if the structure is likely deform, the mounting hardware included in the anchor kit will provide better results.

Anchor Kit

The anchor kit contains one stainless steel M10 x 200 mm all-thread stud, an angle bracket, low-friction bushings, and other hardware. Use two anchor kits for a single beam. Linked beams share anchors, so use one anchor kit for each beam plus one anchor kit for the last beam.

EL Tilt Sensor

The horizontal tilt sensor fits inside the horizontal beam. The vertical beam is supplied in a separate housing that clamps onto the beam.

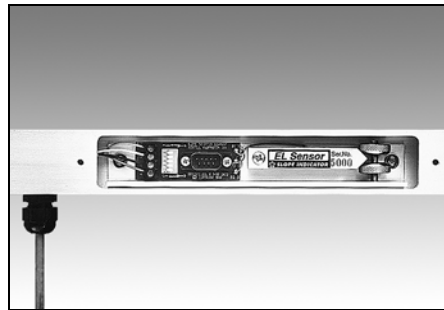

Horizontal tilt sensor

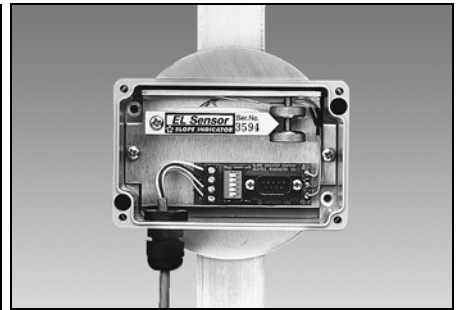

Vertical tilt sensor

Terminal Board

The tilt sensors may be supplied with a standard terminal board or an SC (Signal Conditioning) terminal board. Wiring and reading methods differ according to the type of board supplied.

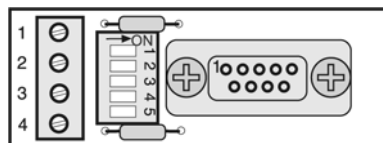

Standard terminal board has 4 terminals. Other notable features are a DB9 connector and a bank of switches.



SC terminal board has 6 terminals. The only other notable feature is the row of four pins at the top of the board.

Installing Horizontal Beam Sensors

Installation Overview

1. Install anchors.
2. Mount sensor inside beam.
3. Install beam.

Installation Materials

- Quick-set epoxy grout, 250 ml or larger package. This is used to secure the all thread anchors in the drill holes.
- Blue Loctite (#242) or equivalent thread-locking compound to keep the sensor in its adjusted position.
- Teflon tape (optional). To be wrapped on anchors to prevent bonding of grout and anchor. Used when anchors must be removed.

Installation Tools

- Spirit level.
- Percussion/hammer drill with 12 to 19 mm masonry drill bit.
- Two adjustable wrenches.
- Two screw drivers, one flat head and one phillips.

Installing Anchors

The beam sensor monitors the relative movement of two anchors. The gauge length of the beam sensor is the distance between the center point of each anchor. You can choose any convenient gauge length. For example, you can have some anchors spaced at 1.5 meters and other anchors at 0.8 meters.

Once anchors are grouted in, you must measure the center to center distance between each anchor carefully, since this value is used in displacement calculations.

1. Mark locations for anchor holes: Draw a horizontal line on the structure, then mark off gauge lengths for each sensor. Linked beams share anchors.
2. Drill anchor holes to depth of about 100 mm. Take care to drill holes at same angle.
3. Remove debris from holes. Mix epoxy grout as directed by manufacturer. Fill hole with grout, then insert anchor.
4. Allow grout to harden before mounting beam.
5. Measure the center to center distance between each pair of anchors.

Mounting Sensor Inside Beam

Skip these instructions if the EL sensor is already mounted inside the beam.

1. Remove cover plate from sensor compartment. Sensor compartment is located in middle of beam.
2. Remove the two mounting screws from back of sensor assembly.
3. Place sensor assembly in sensor compartment, so that mounting holes are aligned with pre-drilled holes in beam.
4. Insert mounting screws through back of beam and into sensor assembly. Tighten screws until sensor assembly is securely fastened to beam.
5. Replace cover plate.

Installing the Beam

Each beam is supplied with end-brackets that can be secured directly to wall anchors. This method of installation is satisfactory with solitary beams that monitor only rotation. However, if beams are linked, or if the structure is likely deform, the mounting hardware included in the anchor kit will provide better results. See installation drawings below and on the next page.

1. Check that anchors are parallel. Bend anchors into line, if necessary.
2. Check that end brackets are inserted into beams, but not completely tight.
3. Fasten angle brackets to anchors, as shown in the drawing at right.
4. Fasten end bracket of beam sensor to angle brackets. Hardware is usually supplied with all washers in place. Use drawing below to see where end brackets and angle brackets fit. Tighten nuts so that spring washers are just slightly compressed.

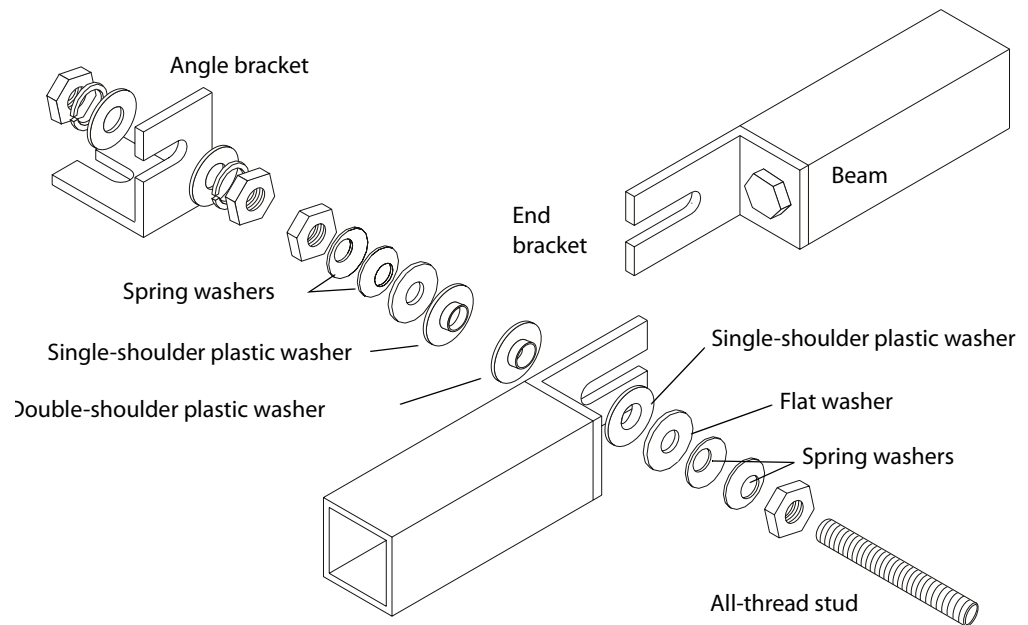
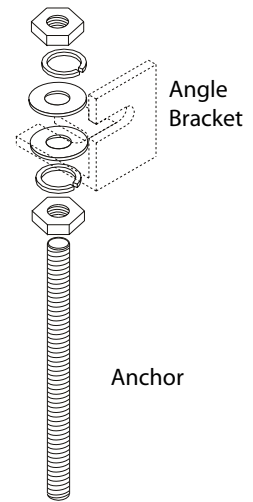

Installing the Beam
continued

5. Check that beam is properly oriented, as shown in the drawings below. Apply thread-locking compound to all nuts.

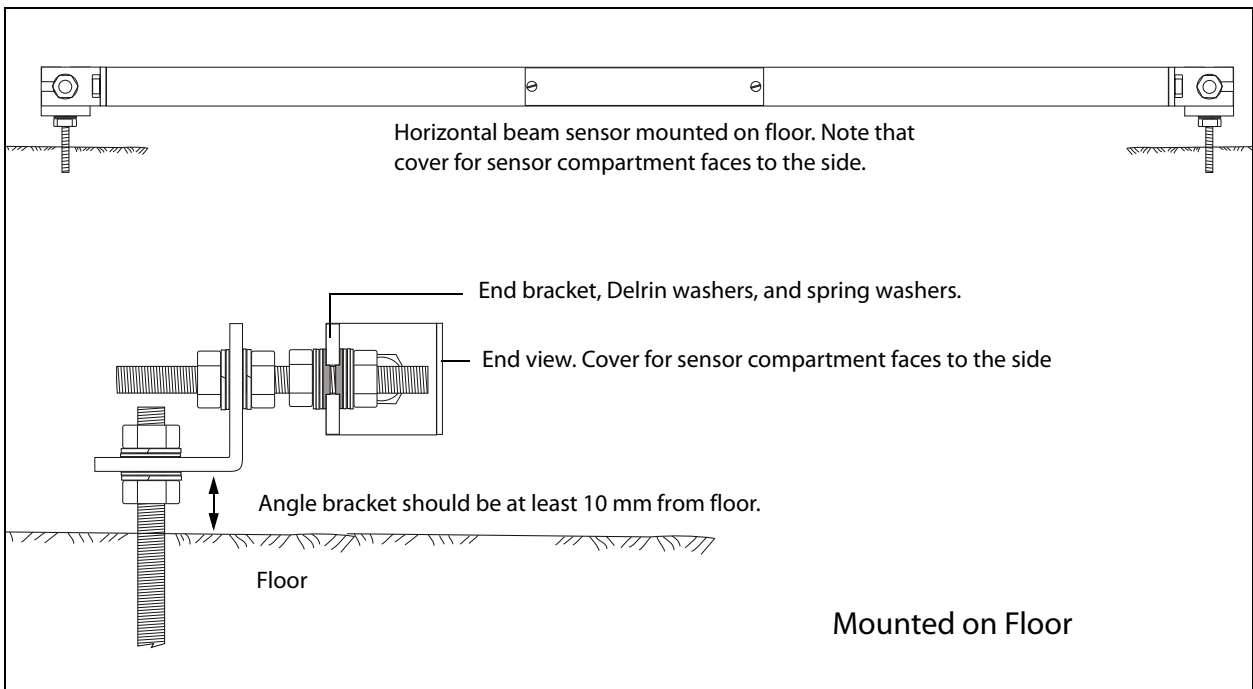
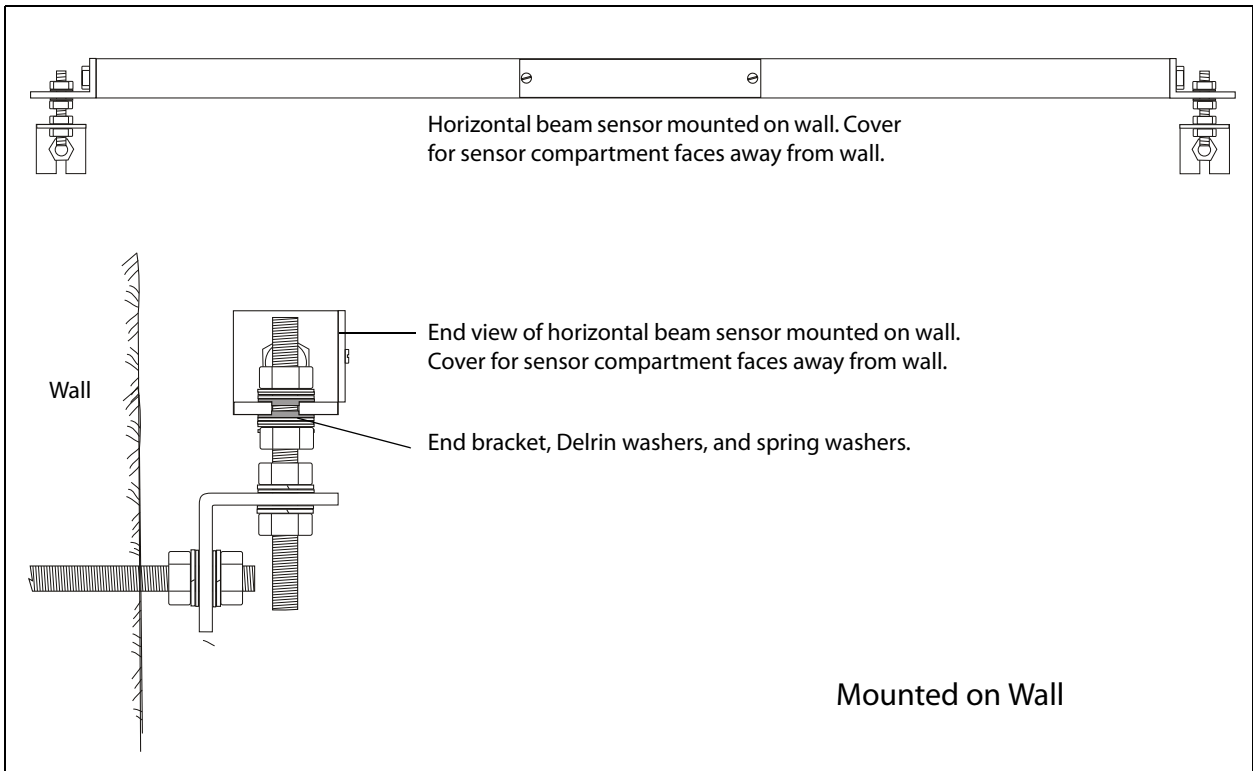

Installing Vertical Beam Sensors

Installation Overview

1. Install anchors.
2. Attach sensor housing to beam.
3. Install beam.

Installation Materials

- Quick-set epoxy grout, 250 ml or larger package. This is used to secure the all thread anchors in the drill holes.
- Blue Loctite (#242) or equivalent thread-locking compound to keep the sensor in its adjusted position.
- Teflon tape (optional). To be wrapped on anchors to prevent bonding of grout and anchor. Used when anchors must be removed.

Installation Tools

- Spirit level.
- Percussion/hammer drill with 12 to 19 mm masonry drill bit.
- Two adjustable wrenches.
- Two screw drivers, one flat head and one phillips.
- 8 mm socket wrench, used to tighten nuts on swivel plate.

Installing Anchors

The beam sensor monitors the relative movement of two anchors. The gauge length of the beam sensor is the distance between the center point of each anchor. You can choose any convenient gauge length. For example, you can have some anchors spaced at 1.5 meters and other anchors at 0.8 meters.

Once anchors are grouted in, you must measure the center to center distance between each anchor carefully, since this value is used in displacement calculations.

1. Mark locations for anchor holes: Draw a vertical line on the structure, then mark off gauge lengths for each sensor. Linked beams share anchors.
2. Drill anchor holes. Take care to drill holes at same angle. Do not use end-brackets as drill guides, since enlargement of slot may interfere with performance of beam sensor.
3. Remove debris from holes. Mix epoxy grout as directed by manufacturer. Fill holes with grout, then insert anchors. Anchor must extend at least 100 mm from wall to provide clearance for sensor housing.
4. Allow grout to harden before mounting beam.
5. Measure the center-to-center distance between each pair of anchors.

Attaching the Sensor to the Beam

1. Remove cover.
2. Attach mounting plate and disks to sensor housing, as shown below. With beam held vertical.
3. Replace cover.
4. Clamp sensor housing to beam. Tighten nuts on clamp.

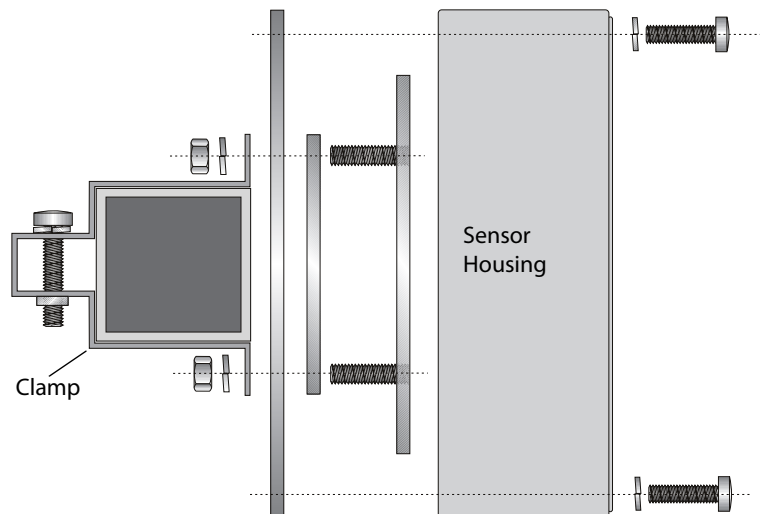

Installing the Beam

Each beam is supplied with end-brackets that can be secured directly to wall anchors. This method of installation is satisfactory with solitary beams that monitor only rotation. However, if beams are linked, or if the structure is likely deform, the mounting hardware included in the anchor kit will provide better results.

See installation drawings below and on the next page.

1. Check that anchors are parallel. Bend anchors into line, if necessary.
2. Fasten angle-brackets onto anchor.
3. Fasten end-brackets of beam to angle brackets. Check that washers are placed as in the drawing on page 5. Tighten nut so that spring washers are just slightly compressed.

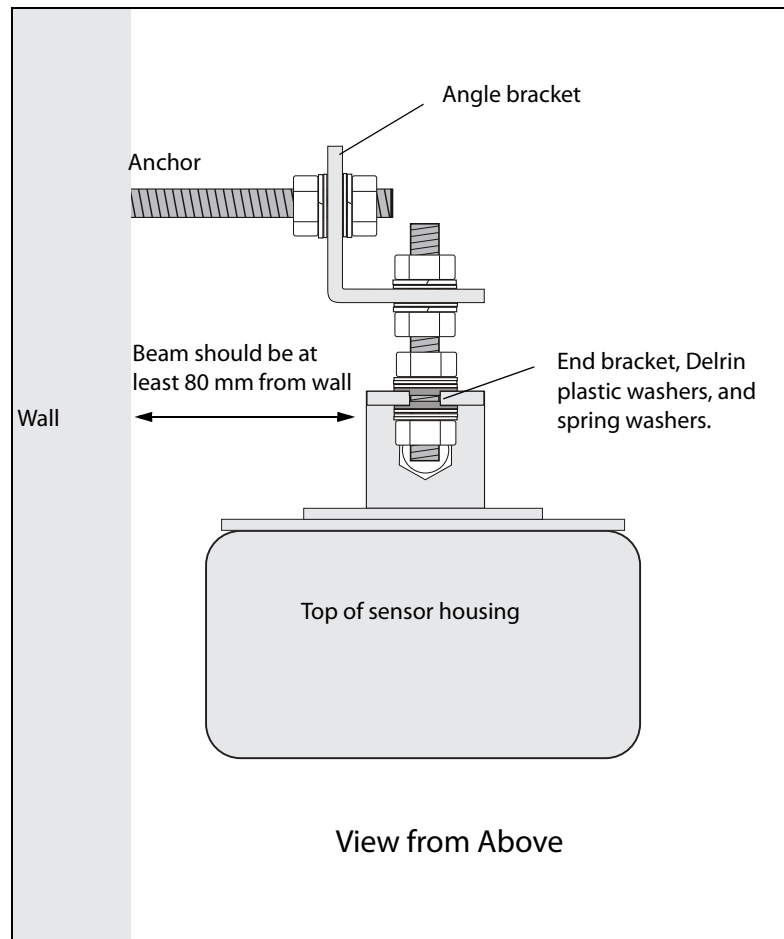

4. Viewed from the front, beam should be near vertical. Viewed from the side, the beam should be roughly parallel with the wall.
5. Check that top of sensor housing is level. To adjust, remove cover, loosen the two mounting screws, and rotate housing. Then tighten mounting screws and replace cover.
6. Apply thread-locking compound to all nuts.

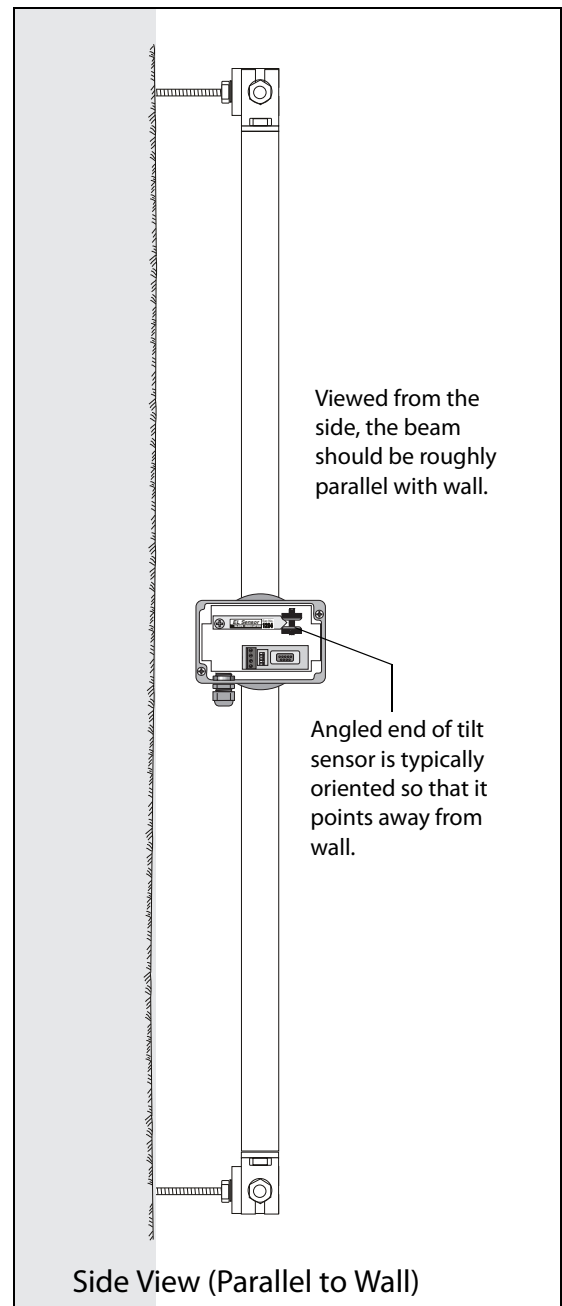
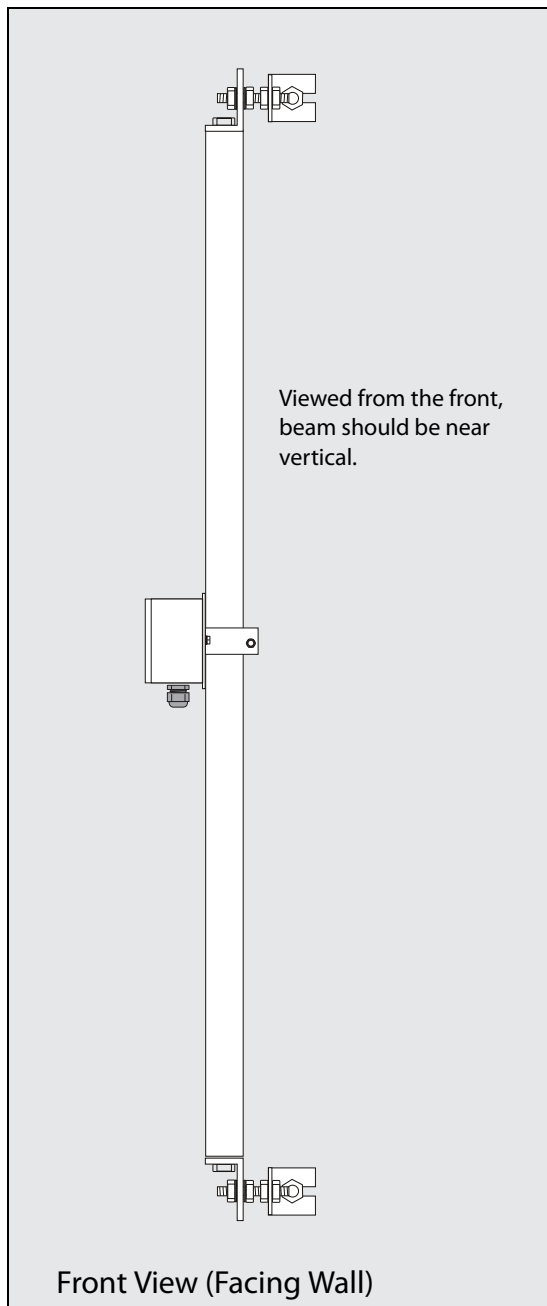

Zero-Adjusting Standard Sensors

Introduction EL sensors with the standard terminal board are “zeroed” with a portable readout, but read with a CR10X data logger. The standard terminal board is shown in the drawing below.

Horizontal tilt sensor with standard terminal board.

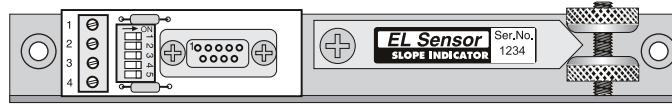

Vertical tilt sensor with standard terminal board

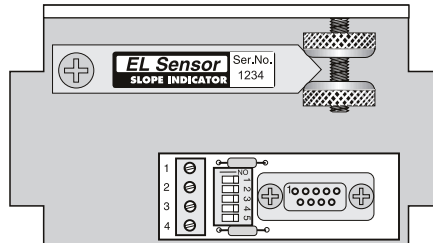

About Zeroing Zeroing is the process of adjusting the sensor so that its output is as close as possible to zero. Since the sensor is very sensitive to even small movements, you must connect signal cable to it before you adjust the sensor. Otherwise, you may have to re-zero the sensor after the signal cable has been attached.

Thus instructions in this chapter take you through two steps:

1. Connecting signal cable to the sensor.
2. Zeroing the sensor.

Connect Signal Cable

1. Remove cover of sensor housing.
2. Set switches 1 through 4 to the OFF position. This disconnects sensor from signal cable terminals.

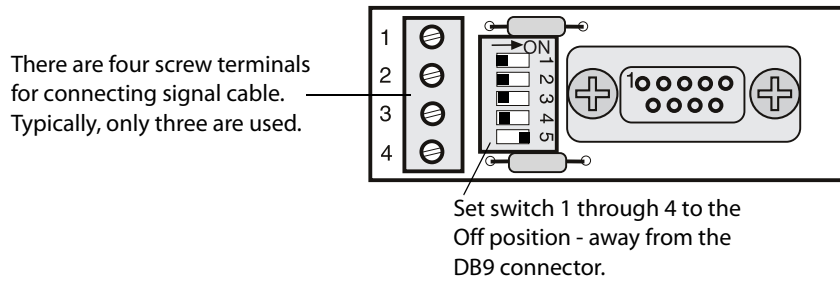

3. Connect signal cable as shown in the table below:

Standard Terminal	Wire Color Cable 50612804	Function
1	White	AC Excitation
2		
3	Green	AC Output
4	Red	Analog Ground
	Drain	Not connected to sensor

After connecting the signal cable, secure it to the wall or floor so that it will not cause the sensor to move.

Note: Any testing of the signal cable should be performed with switches 1 through 4 in the “Off” position. This disconnects the sensor from the signal cable terminals on the sensor board and prevents cable-test operations from damaging the sensor.

Zero the Sensor

Use the DataMate MP readout or the EL-35 readout to zero the sensor. Note that these readouts are used only for zeroing the sensor and not for taking regular readings.

1. Remove cover.
2. Check switches on terminal board. Switches 1 through 4 should be OFF. Switch 5 should be ON.

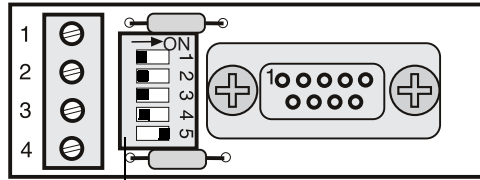

Set switch 1 through 4 to the Off position.
Set switch 5 to the On position.

3. Plug readout into DB9 socket on sensor board and switch on readout.
4. Adjust sensor to zero tilt: Loosen sensor mounting screw and the two thumb nuts to allow adjustment of tilt sensor. Use the thumb nuts to adjust the sensor up or down according to the sign (+ or -) of the reading. The object is to get the reading as close to zero as possible.

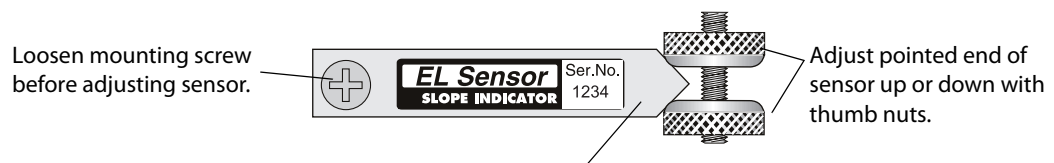

If readings are negative, pointed end of sensor should be moved upward.

If readings are positive, pointed end of sensor should be moved downward.

5. Turn thumb nuts until both are in contact with the sensor, then gently tighten the mounting screw. Finger tight is good enough. Over-tightening can cause the reading to change and stress the sensor.
6. Check to ensure readings are stable for 30 seconds, then switch off readout and disconnect from DB9 socket. Make a note of sensor location and serial number and replace the cover.
7. Apply thread-locking compound to prevent screw and nuts from turning. Note that you may need to adjust sensor again later, so do not use a permanent compound.

Using the DataMate MP

1. Attach the DB9 adapter (part number 57710958) to the DataMate's jumper cable.
2. Switch on the DataMate MP. Choose EL35 RO from the manual mode list. The manual mode key has a check mark. Press the key, then scroll down the list to find EL35 RO. This mode emulates the EL35 readout described below.
3. Plug into the DB9 connector on the terminal board and use the reading to zero the sensor.

Using the EL-35 Readout

1. Connect the EL 35 to the terminal board.
2. Switch on.
3. Use the reading to zero the sensor.

EL-35 Switch Operation

On: Top of switch fully depressed. Backlight is off.

Backlight On: Switch in middle position.

Off: Bottom of switch fully depressed.

EL-35 Display Range

The display units represent approximately 2 arc seconds. The EL tilt sensor has a range of +20 to -20 arc minutes. If the sensor is tilted +20 arc minutes, the EL-35 should read approximately 600, and at -20 arc minutes, the EL-35 should read approximately -600. Readings outside of this range indicate that the sensor should be leveled with the thumb wheels.

Battery

The EL-35 is powered by a single 9-volt alkaline battery. A low-battery symbol appears when it is time to change the battery. The battery door, on the rear of the unit, slides off.

Reading Standard Sensors

Data Logging The standard sensor is read with a CR10X data logger. These instructions below assume that signal cable has already been connected to the sensor. See the previous chapter for details.

CR10X Instructions Use the P78 and P5 instructions for single ended channels.

P78 (Resolution)

- High Resolution

P5 (AC Half Bridge)

- 2500 mV Fast Range
- 2500 mV Excitation
- Multiplier (10)

Wiring for CR10X The exact wiring for the CR10X depends on your program and whether you use multiplexers or not. A generic connection is shown in the table below.

CR10 Terminals	Wire Color 50612524	Sensor Terminal	Function
E	White	1	AC Excitation
		2	Not Used
H or L	Green	3	AC output
AG	Red	4	Analog Ground
G	Drain	Drain wire not connected to sensor	

Setting Switches for CR10X

4. Set the switches as shown below.

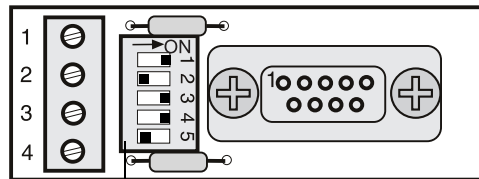

Switches 1, 3, and 4 are ON.
Switches 2 and 5 are OFF

Zero Adjusting SC Sensors

Introduction EL sensors equipped with the SC terminal board can be zeroed and read with a precision voltmeter, the DataMate MP, and most data loggers. The SC terminal board is shown in the drawing below.

Horizontal tilt sensor with SC terminal board.

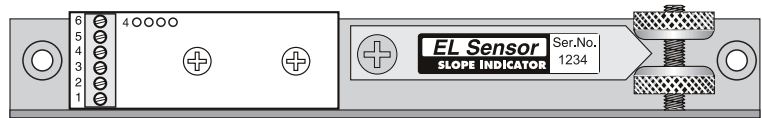

Vertical tilt sensor with SC terminal board.

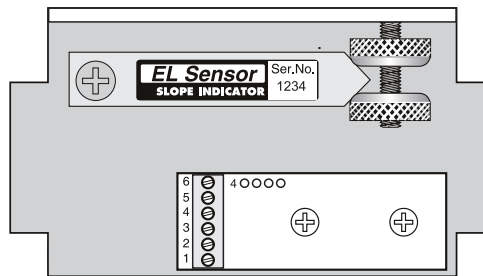

About Zeroing Zeroing is the process of adjusting the sensor so that its output is as close as possible to zero. Since the sensor is very sensitive to even small movements, you must connect signal cable to it before you adjust the sensor. Otherwise, you may have to re-zero the sensor after the signal cable has been attached.

Thus instructions in this chapter take you through two steps:

1. Connecting signal cable to the sensor.
2. Zeroing the sensor. You can zero the sensor with a DataMate MP or with a voltmeter.

Connect Signal Cable

The drawing shows the SC terminal board. Connect signal cables as shown in the table below. After connecting the signal cable, secure it to the wall or floor so that it will not cause the sensor to move

There are six screw terminals for connecting signal cable. Only four or five are typically used with beam sensors.

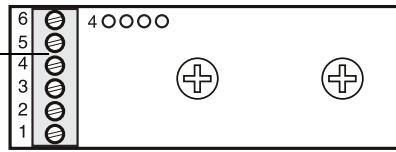

SC Terminal	Wire Color 50612804	Wire Color 50613527	Electrical
1	Green	Green	+Vdc power
2	Black	Black	Ground
3	White	Orange	+Vdc output
4	Red	Yellow	- Vdc output
5		Red	+Vdc

Connect a Readout

Connect the DataMate MP or a Voltmeter to the sensor. See appropriate instructions below.

Connecting the DataMate MP

1. Switch on the DataMate MP. Choose EL SC RO from the manual mode list. The manual mode key has a check mark. Press the key, then scroll down the list to find EL SC RO.
2. Remove cover from sensor housing. Connect the signal cable to the bare-wire adapter (BWA) as shown in the table below. Sometimes sensors are supplied pre-wired to a DB9 connector along with a short adapter cable (57710958) for the DataMate MP. The adapter cable has a DB9F connector that plugs into the DB9 from the sensor. In this case, the bare-wire adapter is not used.

SC Terminal	Wire Color 50612804	Wire Color 50613527	BWA	DB9	Electrical
1	Green	Green	8	6	+Vdc power
2	Black	Black	6	9	Ground
3	White	Orange	1	7	+Vdc output
4	Red	Yellow	2	8	- Vdc output
5		Red	7		+Vdc

Connecting the DataMate MP
continued.

You can also connect to the four pins on the SC terminal board. This is the method used with voltmeter. Wire as shown below.

SC Pins	BWA	Electrical	Function
1	8	+Vdc power	Power
2	6	Ground	
3	1	+Vdc output	Tilt Sensor
4	2	- Vdc output	

Connecting a Voltmeter
and Battery

The voltmeter should display values in the low millivolt dc range. Examples include a Beckman Industrial DM15B voltmeter or a Radio Shack Digital Multimeter (22-802). The power source must supply 5.5 to 15 Vdc. An alkaline 9-volt battery is suitable.

1. Connect the power source to pins 1 (+) and 2 (-).
2. Connect the voltmeter to pins 3 (+ signal) and 4 (- signal).

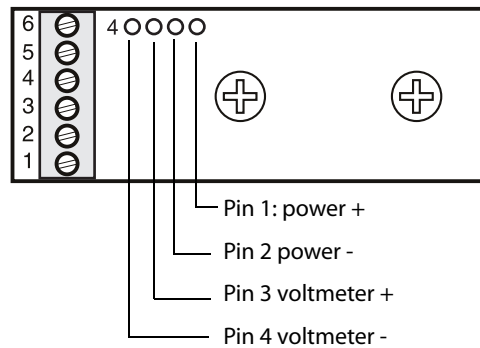

Adjust Zero

1. Adjust sensor to zero tilt: Loosen sensor mounting screw and thumbscrews to allow adjustment of tilt sensor. Use thumb nuts to adjust sensor up or down according to the sign (+ or -) of the reading. The object is to get the reading as close to zero as possible.

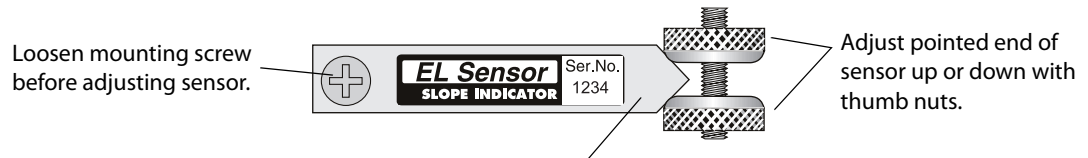

If readings are negative, pointed end of sensor should be moved upward.

If readings are positive, pointed end of sensor should be moved downward.

2. Turn thumb nuts until both are in contact with the sensor, then gently tighten the mounting screw. Finger tight is good enough. Over-tightening can cause the reading to change and stress the sensor.
3. Check to ensure readings are stable for 30 seconds, then disconnect the readout. Make a note of sensor location and serial number and replace the cover.
4. Apply thread-locking compound to prevent screw and nuts from turning. Note that you may need to adjust sensor again later, so do not use a permanent compound.

Reading SC Sensors

Introduction Beam sensors are generally connected to data loggers. However, you can also obtain readings manually using a DataMate MP or a precision voltmeter (one capable of reading to hundredths of a millivolt).

- Manual Readings**
1. Connect the DataMate MP or the voltmeter to the sensor as described in “Zeroing SC Sensors.”
 2. Obtain the reading and write it down.
 3. Later, apply calibration factors to convert the millivolt reading to engineering units, as described in the chapter on Data Reduction.

The instructions above assume that you are using the DataMate MP’s manual mode with EL SC RO selected. Manual mode readings cannot be recorded. If you want to record readings, you must set up a “custom” sensors using the MP Manager. Instructions for setting up a custom configuration for EL-SC sensors are provided in Appendix B of the DataMate MP manual. If your printed manual is too old to have this Appendix, you can find an Acrobat file on the CD supplied with the DataMate.

If you visit Slope Indicator’s website, you can download a sample database that has all the necessary settings to read SC sensors. To download the database, go to www.slopeindicator.com. Click on Support, then click on FAQ and Technotes. Scroll down to the Readout section and click on DataMate MP. Scroll through the DataMate MP FAQ to find the download link for the database.

Each sensor is shipped with its own calibration record and has its own calibration coefficients (c0 to c5). Modify the sensors in the database as required. If you have more than one sensor, make a copy for each sensor, giving it a unique name and entering its unique coefficients.

You may wish to obtain readings in volts, rather than in engineering units. If you use a voltmeter, your readings will be in volts. See the chapter on Data Reduction to learn how to convert the volt reading to engineering units.

Data Logging SC Sensors

SC sensors can be read by data loggers other than the CR10X. The general electrical spec is given in the table below.

Function	SC Terminal	Wire Color 50612804	Wire Color 50613527	Electrical	Range
Power	1	Green	Green	+Vdc power	5.5 to 15 Vdc, requires 3mA max at 12 Vdc
	2	Black	Black	Ground	
Tilt	3	White	Orange	+Vdc output	±250 mV (differential)
	4	Red	Yellow	- Vdc output	
		Drain	Drain		

CR10X Instructions Use the P78 and P5 instructions for single ended channels.

P78 • High Resolution.

P2 • 250 mV Slow range

• Multiplier 0.001

P1 2500 mV Slow Range

Multiplier 0.001

Generic Wiring for CR10X

The exact wiring for the CR10X depends on your program and whether you use multiplexers or not. The table below shows a direct connection to the CR10X. The two schematics on the next page show connections to CR10X and to an AM416 multiplexer.

CR10 Terminals	Wire Color 50612804	Wire Color 50613527	SC Terminal	Function
1L	Red	Yellow	2	Tilt
1H	White	Orange	1	
Switched 12 V	Green	Green	8	Power
GND	Black	Black	6	

**Wiring
Direct to CR10X**

This diagram shows a single EL SC sensor wired directly to a CR10X using cable 50612804.

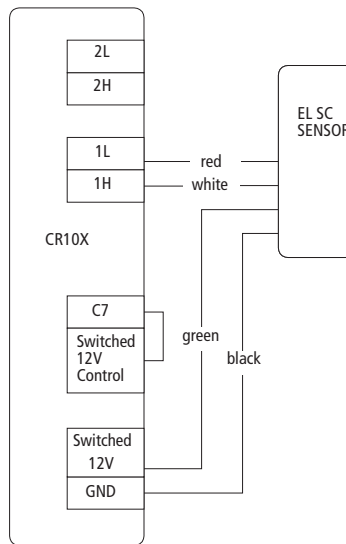

**Wiring
to AM416 Multiplexer**

This diagram shows two EL SC sensors wired to an AM416 multiplexer using cable 50612804.

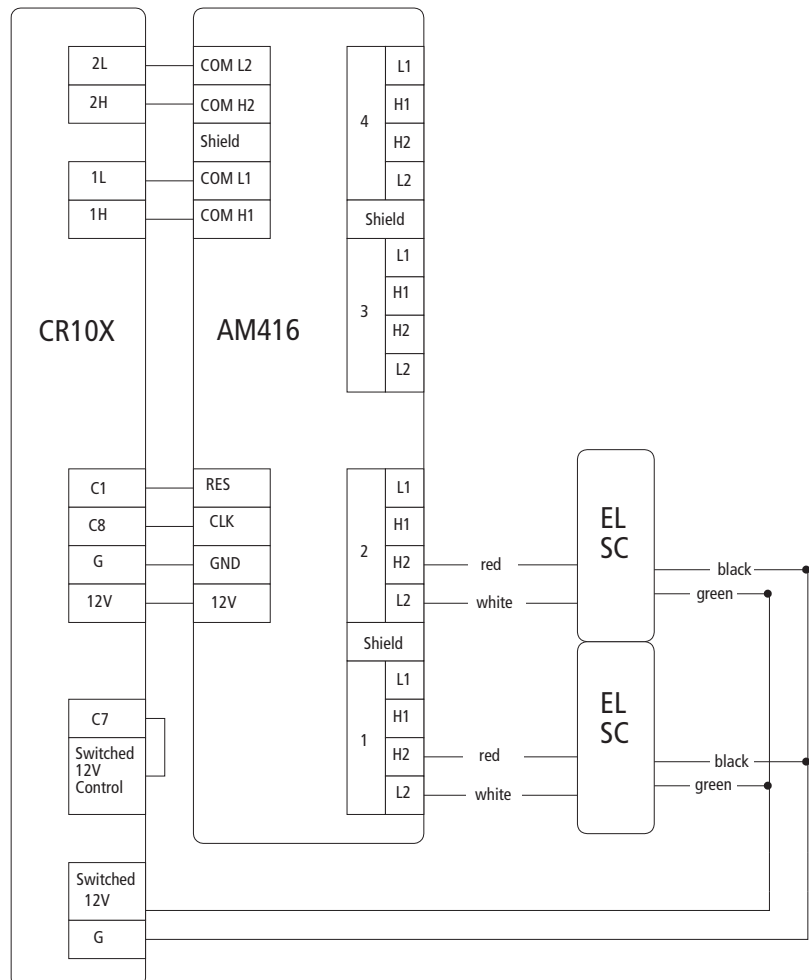

Data Reduction

Overview Data reduction is usually automated because it involves a large number of readings and a large number of calculations. Slope Indicator provides GraphX and MultiMon software for this purpose. These programs can produce a variety of graphs and reports very quickly.

Here, we explain the manual operations required to convert voltage readings to mm of displacement.

1. The EL tilt sensor produces a voltage value that is recorded by the readout or data logger. To convert the voltage value to a tilt value, you must apply calibration factors listed on the sensor calibration sheet.
2. The factors on the sensor calibration sheet are coefficients for a 5th order polynomial equation. Processing the voltage reading with this equation transforms the voltage reading into tilt in units of mm per meter. (Think of this tilt value as “grade” in tenths of a percent).
3. Multiply the tilt by the gauge length of the beam sensor (the center-to-center distance between anchors). This results in a reading in mm.
4. To find displacement, the distance that one anchor has moved relative to the other, subtract the initial reading in mm from the current reading in mm.

Data Reduction Example

Suppose you obtain a reading of 0.144 volts from beam sensor that has a gauge length of 2 meters.

Calibration Sheets

Find the calibration sheet for your sensor. Find the “Polynomial factors CR10.” These are coefficients for a 5th order polynomial. They work with any data. At right, we list factors for sensor 8229. Your sensors will have different factors.

C0	-0.0564854
C1	29.3996
C2	18.158
C3	929.022
C4	-1022.16
C5	14071.3

Convert voltage reading to tilt in mm per meter

Process the voltage reading with the polynomial equation shown below. C5 through C0 are the coefficients that appear on the sensor calibration record. EL is the voltage reading from the sensor, in this case 0.144 V. The result of the calculation is a value in mm per meter.

$$\text{mm/meter} = C5 \cdot EL^5 + C4 \cdot EL^4 + C3 \cdot EL^3 + C2 \cdot EL^2 + C1 \cdot EL + C0$$

	C Factor	EL Reading	Value
C0	-0.0564854		-0.0564854
C1	29.3996	0.144	4.233524
C2	18.158	0.1442	0.376524288
C3	929.022	0.1443	2.774044828
C4	-1022.16	0.1444	-0.43951009
C5	14071.3	0.1445	0.871257807
mm per meter deviation =			7.759005232

Apply gauge length

Multiply the mm/meter value by the gauge length of the sensor.

$$\text{reading in mm} = \text{mm/meter value} \cdot \text{gauge length of sensor}$$

In this example, the gauge length of the beam is 2 meters, so the reading in mm is 2×7.759005232 or about 15.52 mm.

Calculate Displacement

To calculate displacement, subtract the initial reading from the current reading.

$$\text{displacement in mm} = \text{current reading} - \text{initial reading}.$$

If the initial reading were 10 mm, then displacement would be about 5.52 mm.

Direction of Movement

The beam sensor spans the distance between two anchors. When the beam sensor reading changes, it means that one anchor has moved relative to the other anchor.

- With horizontal sensors, one anchor has moved up or down relative to the other anchor.
- With vertical sensors, one anchor has moved laterally (right or left) relative to the other anchor.

Tilt of the Sensor

In the process of zeroing the sensor, you move its angled end up or down relative to the mounting screw. Moving the angled end above horizontal results in a positive (+) reading. Moving the angled end below horizontal results in a negative (-) reading.

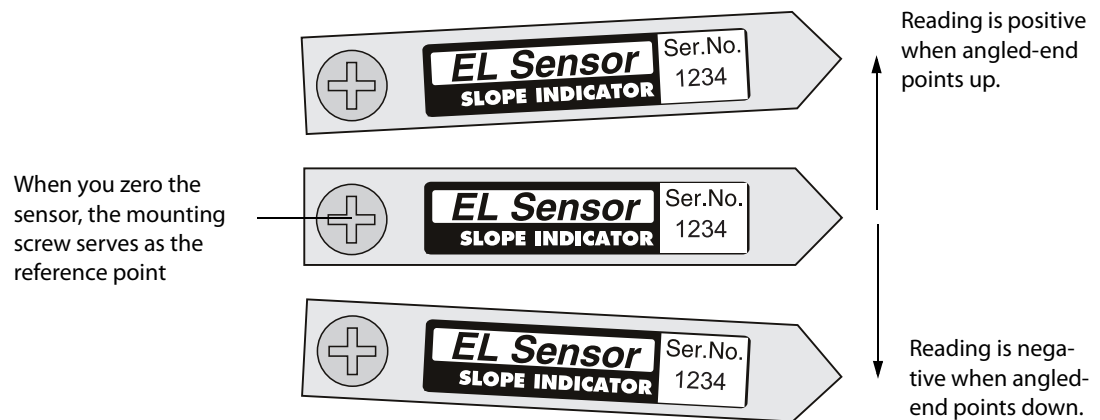

Note that the relation between up and positive and down and negative would be reversed if you held the angled-end of the sensor and moved the screw end up or down.

Thus in determining the direction of movement, you must choose a reference point. In the case of the beam sensor, you must choose an anchor to serve as the reference.

Reference Point and Direction of Movement

The drawings below show how the reference point affects the direction of movement.

