

EL In-Place Inclinometer Multiplexed Version 56804599

Copyright ©2000 Slope Indicator Company. All Rights Reserved.

This equipment should be installed, maintained, and operated by technically qualified personnel. Any errors or omissions in data, or the interpretation of data, are not the responsibility of Slope Indicator Company. The information herein is subject to change without notification.

This document contains information that is proprietary to Slope Indicator company and is subject to return upon request. It is transmitted for the sole purpose of aiding the transaction of business between Slope Indicator Company and the recipient. All information, data, designs, and drawings contained herein are proprietary to and the property of Slope Indicator Company, and may not be reproduced or copied in any form, by photocopy or any other means, including disclosure to outside parties, directly or indirectly, without permission in writing from Slope Indicator Company.

Slope Indicator Company
A Boart Longyear Group Company
3450 Monte Villa Parkway
Bothell, WA 98021-8906 USA
Tel: 425-806-2200 Fax: 425-806-2250
E-mail: solutions@slope.com
Website: www.slopeindicator.com



Contents

Introduction.....	1
Components	3
Pre-Assembly	5
Installation	6
Data Logging.....	10
Data Reduction.....	14

EL In-Place Inclinometer Multiplexed Version

Introduction Inclinometer casing is typically installed in a near-vertical bore-hole or horizontal trench that passes through a zone of suspected movement. The string of in-place inclinometer sensors is positioned in the casing to span this zone.

Ground movement displaces the casing, forcing it from its initial position to a new position. The inclinometer sensor does not measure this displacement directly. Instead, it measures its own inclination (tilt angle), which changes when the casing moves.

Deviation The tilt angle is converted to a lateral distance, which is called deviation. Deviation is calculated by multiplying the sine of the angle by the gauge length of the sensor: $L \sin \theta$.

In the drawing at right, θ is the inclination of the casing, and L is the gauge length of the sensor, which extends from fixed wheel of one sensor to the fixed wheel of the next sensor.

A cumulative deviation plot is made by summing deviations from the bottom to each successive interval.

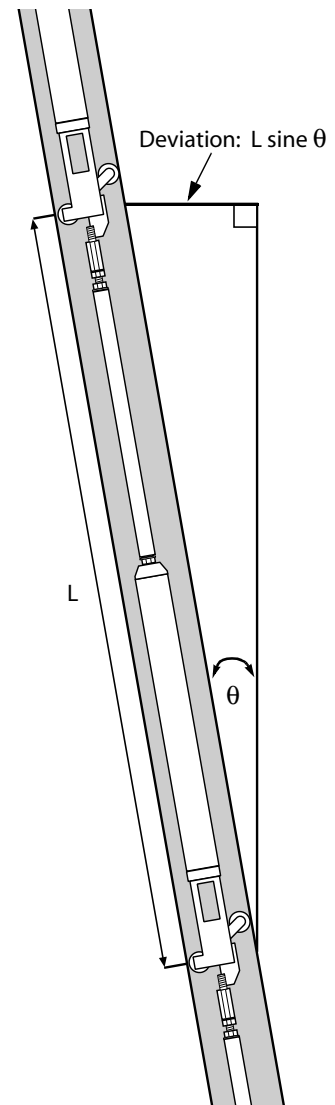

Displacement Displacement, the distance the casing has moved, is calculated by subtracting the initial deviation from the current deviation. The displacement value will be negative or positive. This indicates the direction of movement, as shown below.

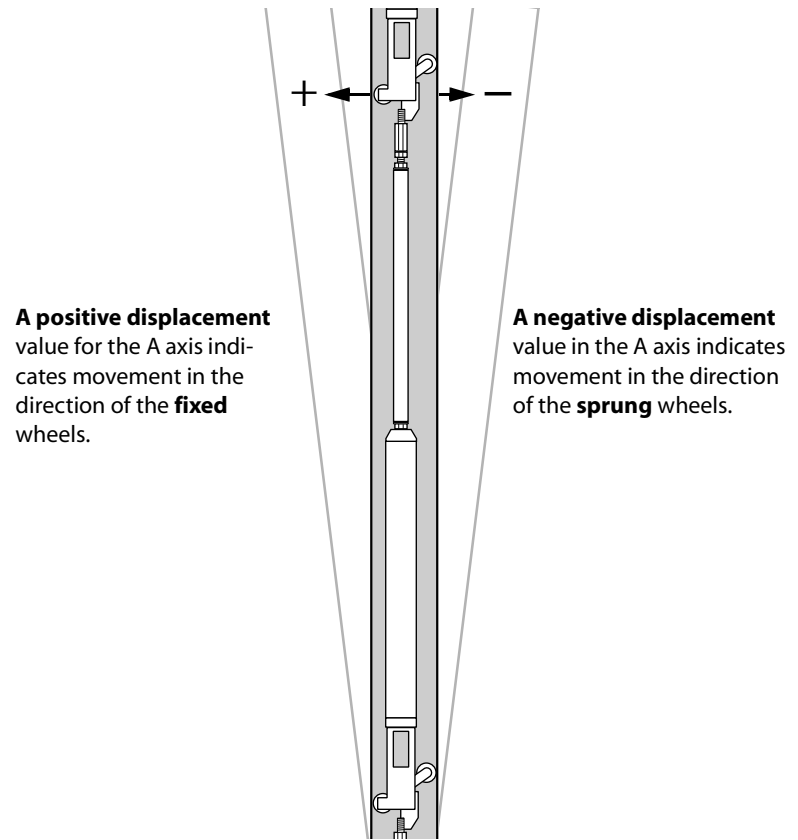

Direction of Movement The displacement value shows the magnitude of movement. The sign (+ or -) shows the direction of movement.

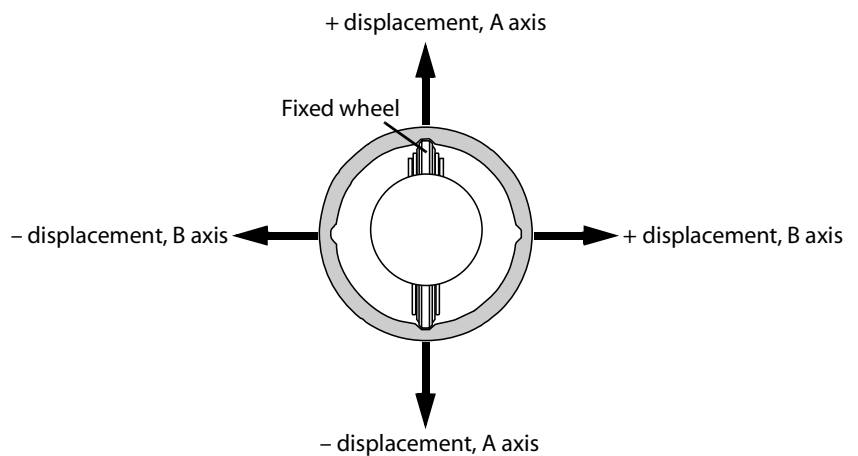

Components

Components of IPI Sensor



Gauge tubing: Completes gauge length of sensor.



Sensor Node: Component of multiplexer system that is installed on gauge tubing of each sensor. Two cables exit bottom, one cable exits top.



Tubing clamp: Connects gauge tubing to the sensor body.

Top clamp: Used to suspend sensors from top of casing.

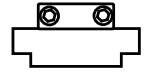

Coupling: Connects lengths of placement tubing.

Placement tubing: (not shown) suspends sensors from top of inclinometer casing.

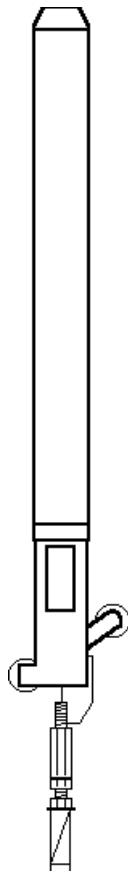
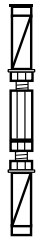

IPI sensor: Includes wheel assembly and top and bottom tubing clamps. Tapered end of sensor is the top.

In-line wheel assembly: Used to terminate gauge length of top sensor.

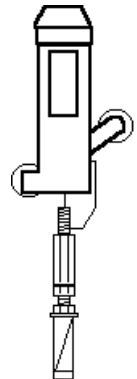

Swivel clamp: Locks the swivel on the bottom wheel assembly.

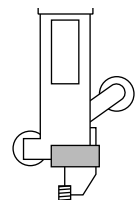

Tubing clamp: Connects the sensor to the gauge tubing of another sensor. Supplied with the sensor.

Gauge Tubing

Gauge tubing may be pre-cut and supplied with the sensors. If gauge tubing is not supplied, check project specifications for required gauge length, and then follow the instructions below:

1. Choose stainless tubing that can accept tubing clamps. The standard tubing clamps have a minimum ID of 15.6 mm (0.615 inch) and expand to a maximum ID of 17.4 mm (0.685 inch).
2. Measure and mark the gauge tubing for the proper length: tubing length = total gauge length – 550 mm (21.625 inch). For example, you would cut tubing lengths of 1450 mm for a total gauge length of 2 meters.
3. Cut and deburr the gauge tubing. Check that tubing clamps fit inside.

Placement Tubing

Placement tubing is used to suspend the string of sensors from the top of the inclinometer casing. Use the coupling shown on previous page to join lengths of placement tubing. Use in-line wheel assembly if placement tubing must be articulated. If placement tubing is not supplied with the sensors, follow the instructions below:

1. Choose stainless tubing that can accept tubing clamps and couplings. The standard tubing clamps have a minimum ID of 15.6 mm (0.615 inch) and expand to a maximum ID of 17.4 mm (0.685 inch).
2. Deburr the gauge tubing and check that tubing clamps fit inside.

Pre-Assembly

Identify Sensors

1. Sensors are pre-wired into strings at the factory. Each string is packed into its own box along with calibration records for each sensor in the string. Match each string with its intended bore-hole (casing installation).
2. Verify the serial number and position of each sensor in the string. The bottom sensor has a swivel clamp attached to its wheels, as shown.
3. As you work, be careful not to bend or damage the wheel assembly as you work.

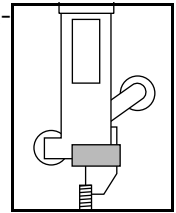

Attach Gauge Tubing to Each Sensor

Attach gauge tubing to sensors as follows:

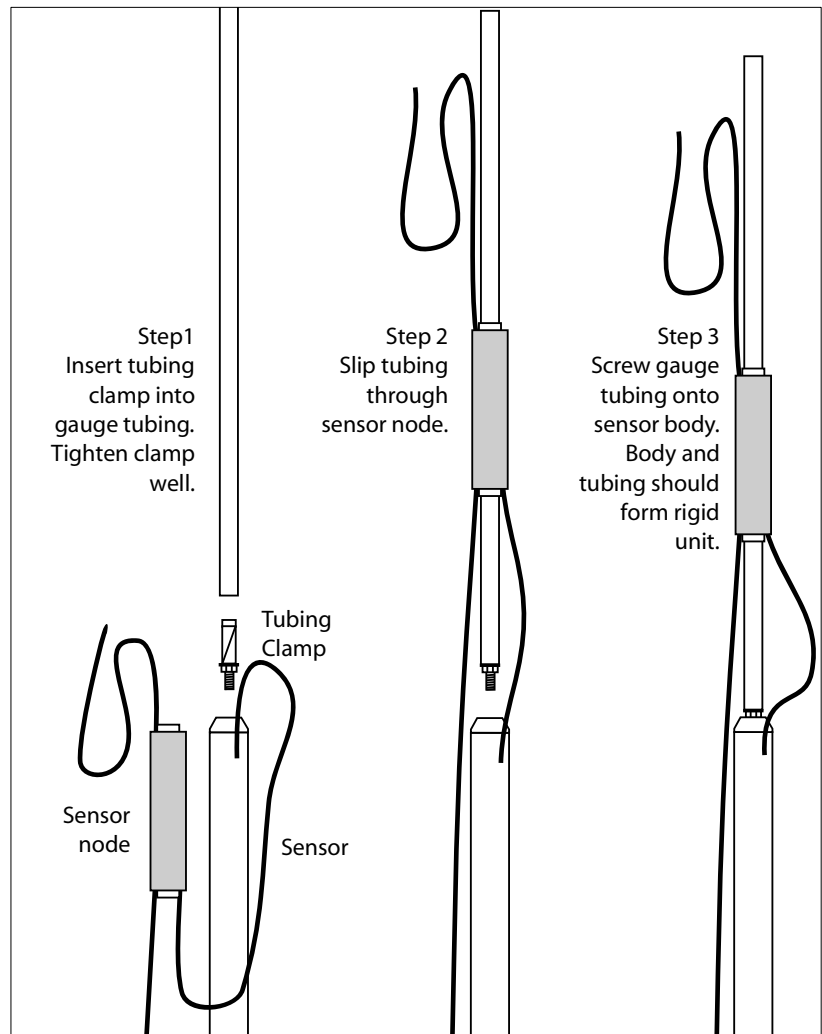

Installation

- Overview** Installation involves connecting each sensor to the next as the sensor string is lowered into the casing.
1. Align the fixed wheel of the first sensor in the preferred set of grooves.
 2. Lower the sensor into the casing until the top of its gauge tubing is accessible.
 3. Connect the next sensor to the gauge tubing of the downhole sensor. Then lower it into the casing.
 4. Continue connecting sensors until the string is complete.
 5. Connect the final wheel assembly and placement tubing.
 6. Suspend the sensor string from the top clamp.

- Required Tools**
- Rope or cable attached to bottom sensor to (1) prevent loss of sensors down hole, and (2) control the position of the string during installation. A winch may be useful if there are many sensors.
 - Vice grips (clamping pliers) for holding gauge tubing while connecting adjacent sensors.
 - Allen wrench for securing top clamp.
 - Cable ties and vinyl tape for securing cable to gauge tubing.

- Preparations**
1. Attach gauge tubing to each sensor, as explained on the previous page.
 2. Lay out sensors close to the borehole.

Install Bottom Sensor

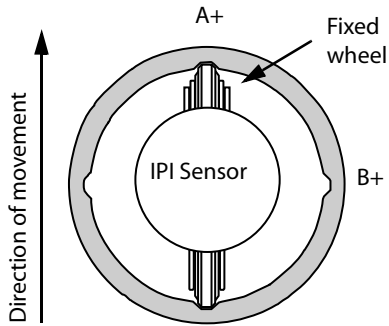

Vertical Inclinometer Casing

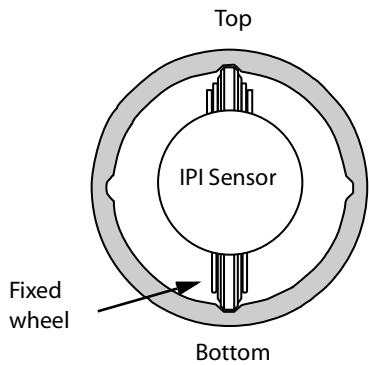

Horizontal Inclinometer Casing

1. Attach safety line (nylon or wire rope) to bottom sensor.
2. Align the fixed wheel with the preferred set of grooves:
 - In vertical installations, casing is oriented so that one set of grooves is aligned in the direction of expected movement. Align the fixed wheel of the sensor toward the direction of movement, as shown in the drawing at left.
 - In horizontal installations, casing is oriented so that one set of grooves is aligned to vertical. Insert the fixed wheel of the sensor in the bottom groove, as shown at left.
3. Lower sensor into casing. Use cable ties to fix position of multiplexer node and signal cable.
4. Use vice grips to clamp top of gauge tubing. Now the next sensor can be installed.

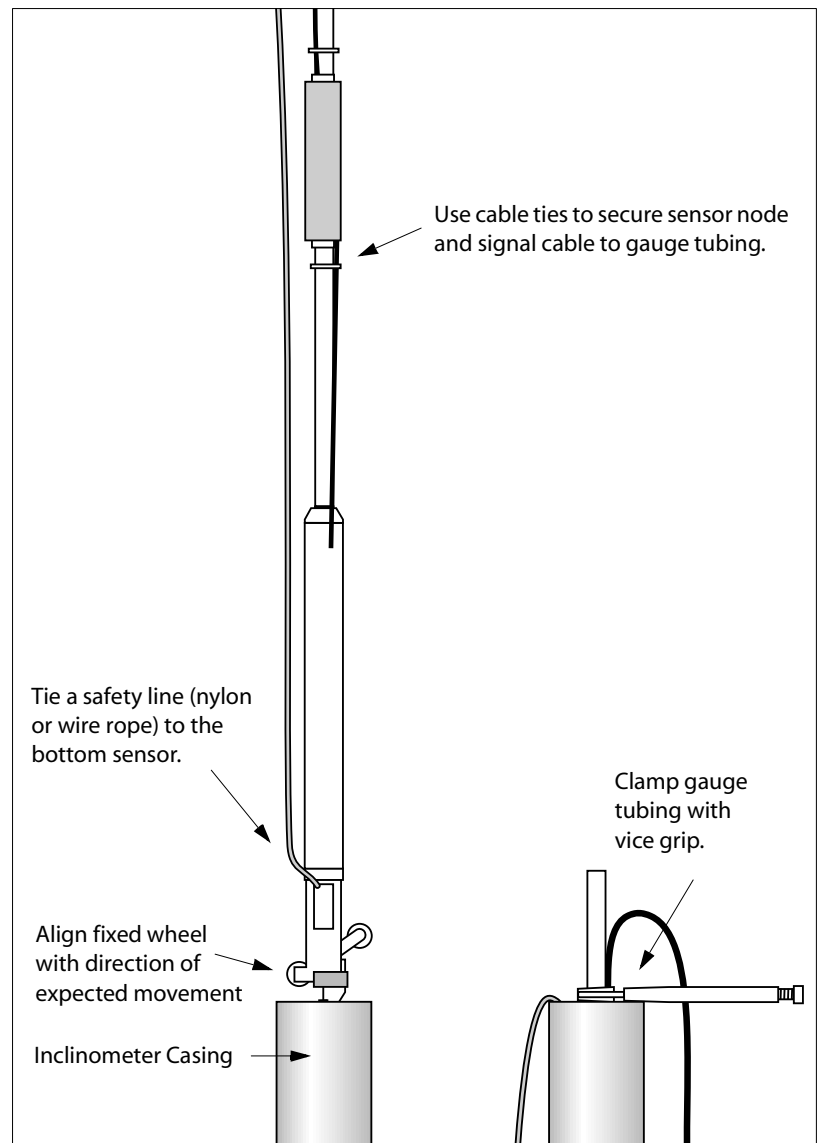

Install Next Sensor

1. Connect next sensor to the gauge tubing of the sensor below, as shown in the drawing. Continue adding sensors until the sensor string is complete. Keep the following points in mind:
 - Do not allow the installed sensor to twist in the casing when you tighten the connection. Twisting can damage the wheels or pop them out of the grooves.
 - When you lower the sensor into the casing, check that the fixed wheel is aligned in the proper direction.
 - Use cable ties to secure cables and sensor nodes to gauge tubing.

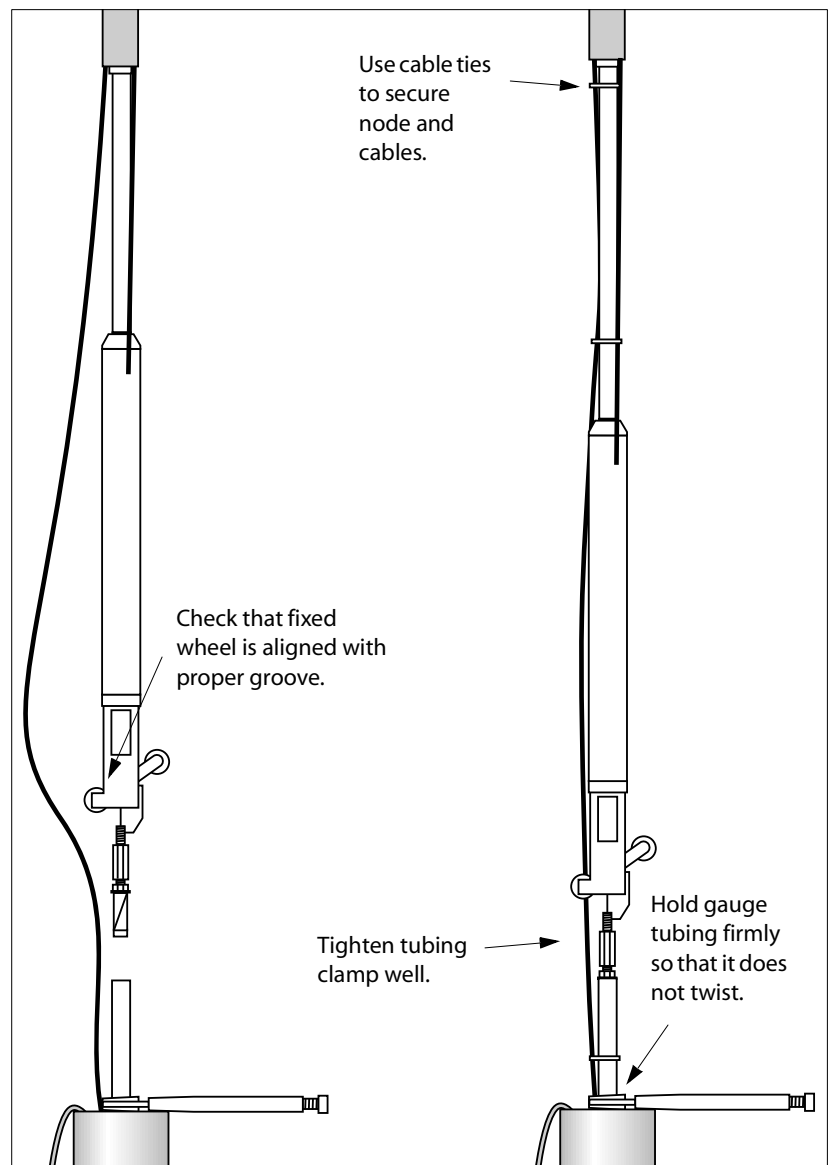

Install In-Line Wheel, Placement Tubing, and Top Clamp

The in-line wheel assembly terminates the gauge length of the last sensor in the string. Placement tubing allows the string to be suspended deeper in the casing. The top clamp holds the placement tubing.

1. Attach wheel assembly to gauge tubing of last sensor.
2. Check that placement tubing is the right length. Then attach to wheel assembly.
3. Finally, suspend the entire sensor string from the top clamp. The top clamp has a split collar. Loosen the screws, slide the collar over the placement tubing or gauge tubing, and then tighten the screws

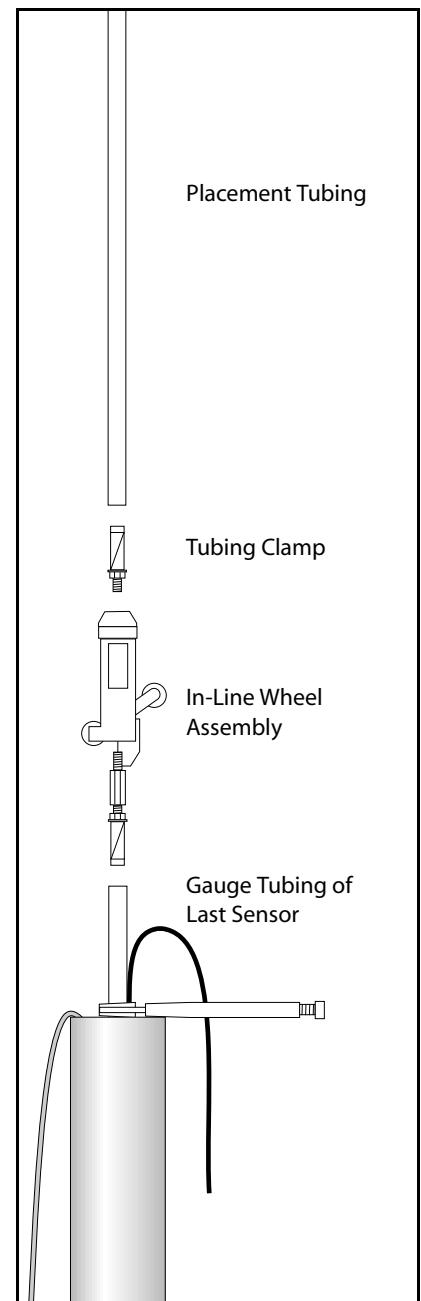
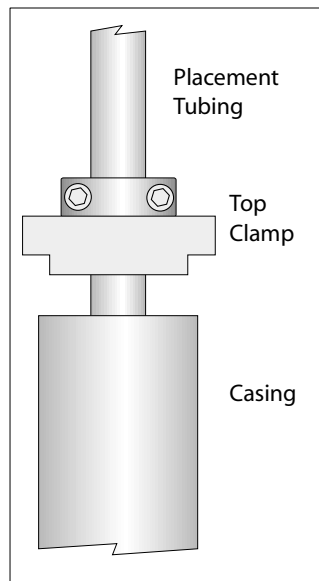

DataLogging

Hardware Requirements

- Campbell Scientific CR10X Data Logger with program
- Super Node (Part of multiplexer system) for each sensor string
- Sensor Nodes (Installed with each sensor)

Software Requirements

- PC 208W for communicating between PC and data logger.
- Monitoring program for CR10X
- Data reduction program, such as MultiMon, which is configured for the sensors in each string.

Typical Wiring

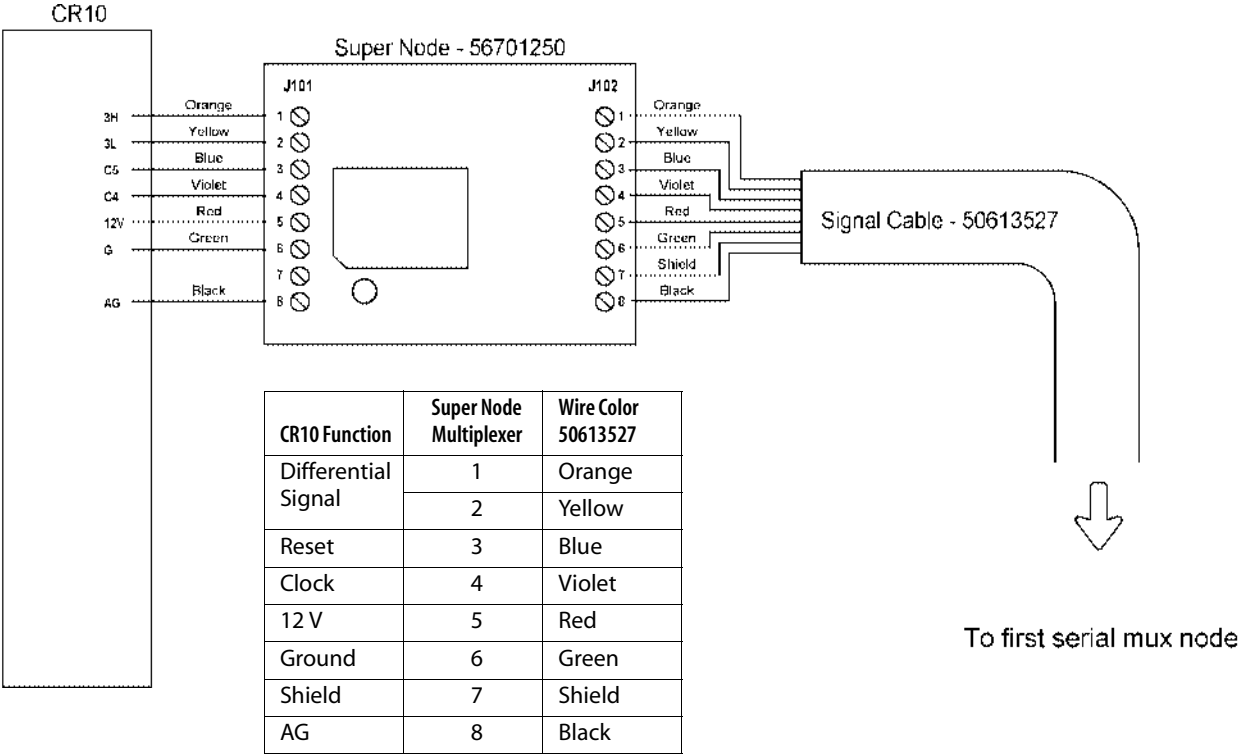

Sample Program

This is a typical program used to read the multiplexer version of 10 biaxial EL IPI sensors.

```

;{CR10}
;Smux-b10.csi
;Date 31-May-2000, by Hai Tien Yu
;
;Demo logger program to read 10 biaxial EL IPIs with serial mux ;node.
;
*Table 1 Program
  01: 30      Execution Interval (seconds)

1:  Batt Voltage (P10)
  1: 31      Loc [ Battery  ]

2:  Internal Temperature (P17)
  1: 32      Loc [ CR10Temp ]

3:  Do (P86)
  1: 81      Call Subroutine 81 ;----- read 10 uniaxial IPI in one chain

4:  If time is (P92)
  1: 0000    Minutes (Seconds --) into a
  2: 1       Interval (same units as above)
  3: 10      Set Output Flag High

5:  Set Active Storage Area (P80)
  1: 1       Final Storage Area 1
  2: 1       Array ID

6:  Real Time (P77)
  1: 1110    Year,Day,Hour/Minute (midnight = 0000)

7:  Resolution (P78)
  1: 1       High Resolution

8:  Sample (P70)
  1: 20      Reps
  2: 1       Loc [ ELA_1    ]

9:  Resolution (P78)
  1: 0       Low Resolution

10: Sample (P70)
  1: 10      Reps
  2: 21      Loc [ ELT_1    ]

11: Sample (P70)
  1: 2       Reps
  2: 31      Loc [ Battery  ]

*Table 2 Program
  02: 0.0000 Execution Interval (seconds)

*Table 3 Subroutines

1:  Beginning of Subroutine (P85) ;----- 81 ----- Read 10 biaxial
IPI's -----
  1: 81      Subroutine 81 ;

;   RESET ONE STRING BY SWITCH POWER TO SUPER NODE ON

  2:  Do (P86)
    1: 55      Set Port 5 Low

  3:  Excitation with Delay (P22)
    1: 3       Ex Channel
    2: 100     Delay W/Ex (units = 0.01 sec)
    3: 0000    Delay After Ex (units = 0.01 sec)
    4: 0000    mV Excitation

  4:  Do (P86)
    1: 45      Set Port 5 High

  5:  Excitation with Delay (P22)
```

```

1: 3      Ex Channel
2: 100    Delay W/Ex (units = 0.01 sec)
3: 0000   Delay After Ex (units = 0.01 sec)
4: 0000   mV Excitation

x = 10

6: Beginning of Loop (P87)
1: 0000   Delay
2: 10     Loop Count

      x = x + 10

7: Do (P86)
1: 92     Call Subroutine 92 ;----- Pulse port 4 then delay x sec-
ond

8: Do (P86)
1: 93     Call Subroutine 93 ;----- Read one EL sensor -----

9: Z=X (P31)
1: 36     X Loc [ Average   ]
2: 1      -- Z Loc [ ELA_1   ]

10: Do (P86)
1: 92     Call Subroutine 92 ;----- Pulse port 4 then delay x sec-
ond

11: Do (P86)
1: 94     Call Subroutine 94 ;----- Read one temp sensor -----

12: Z=X (P31)
1: 37     X Loc [ ELTemp    ]
2: 21     -- Z Loc [ ELT_1   ]

      x = x + 10

13: Do (P86)
1: 92     Call Subroutine 92 ;----- Pulse port 4 then delay x sec-
ond

14: Do (P86)
1: 93     Call Subroutine 93 ;----- Read one EL sensor -----

15: Z=X (P31)
1: 36     X Loc [ Average   ]
2: 11     -- Z Loc [ ELB_1   ]

16: Do (P86)
1: 92     Call Subroutine 92 ;----- Pulse port 4 then delay x sec-
ond

;        17: Do (P86)
;        1: 94     Call Subroutine 94 ;----- Read one temp sensor -----

;        17: Z=X (P31)
;        1: 37     X Loc [ ELTemp    ]
;        2: 0      -- Z Loc [ _____ ]

17: End (P95)

18: Do (P86)
1: 55     Set Port 5 Low

19: End (P95)

20: Beginning of Subroutine (P85) ;----- 92 ----- Pulse port 4 then
delay x second -----
1: 92     Subroutine 92 ;

21: Do (P86)
1: 74     Pulse Port 4

Counter=0

```

```

22: Beginning of Loop (P87)
   1: 0000 Delay
   2: 9999 Loop Count

       23: Z=Z+1 (P32)
         1: 33 Z Loc [ Counter ]

       24: Excitation with Delay (P22)
         1: 3 Ex Channel
         2: 10 Delay W/Ex (units = 0.01 sec)
         3: 0000 Delay After Ex (units = 0.01 sec)
         4: 0000 mV Excitation

       25: If (X<=>Y) (P88)
         1: 33 X Loc [ Counter ]
         2: 3 >=
         3: 34 Y Loc [ x ]
         4: 31 Exit Loop if True

26: End (P95)

27: End (P95)

28: Beginning of Subroutine (P85) ;----- 93 ----- Read one EL sen-
sor -----
   1: 93 Subroutine 93

Average=0

29: Beginning of Loop (P87)
   1: 0000 Delay
   2: 100 Loop Count

       30: Volt (Diff) (P2)
         1: 1 Reps
         2: 24 250 mV 60 Hz Rejection Range
         3: 3 DIFF Channel
         4: 35 Loc [ Single ]
         5: 0.01 Mult
         6: 0.0 Offset

       Average=Average+Single

31: End (P95)

32: End (P95)

33: Beginning of Subroutine (P85) ;----- 94 ----- Read one temp
sensor -----
   1: 94 Subroutine 94

       34: Volt (Diff) (P2)
         1: 1 Reps
         2: 25 2500 mV 60 Hz Rejection Range
         3: 3 DIFF Channel
         4: 37 Loc [ ELTemp ]
         5: 0.0004 Mult
         6: 0.0 Offset

       35: Polynomial (P55)
         1: 1 Reps
         2: 37 X Loc [ ELTemp ]
         3: 37 F(X) Loc [ ELTemp ]
         4: -39.366 C0
         5: 373.51 C1
         6: -1194.2 C2
         7: 2587.6 C3
         8: -2836 C4
         9: 1264.9 C5

36: End (P95)

End Program

```

Data Reduction

Introduction Data reduction is usually automated because it involves a large number of readings and a large number of calculations.

Here, we explain how to use the sensor calibration record and provide an example of converting a single reading from voltage to mm of deviation.

Once you have deviations, you can calculate displacements (movements) by subtracting the initial deviation from the current deviation.

Calibration Record A calibration record is provided with each EL IPI sensor. Note that calibrations are unique for each sensor, so use sensor serial numbers to match sensors with their calibrations.

The sensor calibration record lists three sets of factors for each axis of the sensor and one factor for the temperature sensor. The table at right shows factors for sensor serial number 10001. Your sensors will have different factors.

C0 to C5: Use these factors to convert a reading in volts to mm per meter of gauge length.

S0 to S2: Use these factors to adjust the mm/m value above for temperature-related changes in sensor sensitivity.

F0 to F2: Use these factors to adjust the mm/meter value for temperature-related changes in the offset of the sensor.

Toffset: Use this factor in the equation to convert a thermistor reading in volts to degrees C.

Tnom: Tnom is normally 12 degrees C. However, the value shown on the sensor calibration record may be higher or lower if your sensors were calibrated over a custom range of temperatures.

C0	-7.0311
C1	738.78
C2	-22.265
C3	-330.79
C4	194.26
C5	2022.1
S0	1
S1	0.00059828
S2	0.0000068117
F0	00012125
F1	0.016273
F2	0.00096919
Toffset	0.19
Tnom	12

Applying Calibration Factors

Suppose you obtain a reading of 57 millivolts (0.057V) from sensor 10001, which has a gauge length of 2 meters. How do you convert the voltage reading to mm of deviation? How do you correct for temperature effects? The temperature at the time of reading was 19.3 degrees C.

Converting sensor reading to mm per meter

Apply the C factors to the voltage reading as shown below. EL represents a reading in volts. C5 through C0 are factors that appear on the sensor calibration record. The result of the calculation is a value in mm per meter.

$$\text{mm/meter} = C5 \cdot EL^5 + C4 \cdot EL^4 + C3 \cdot EL^3 + C2 \cdot EL^2 + C1 \cdot EL + C0$$

	C Factor	EL Reading	Value
C0	-7.0311		-70311
C1	738.78	0.057	42.11046
C2	-22.265	0.057 ²	-0.07234
C3	-330.79	0.057 ³	-0.06126
C4	194.26	0.057 ⁴	0.002051
C5	2022.1	0.057 ⁵	0.001217
mm per meter deviation =			34.94903

Calculating deviation in mm

To calculate deviation in mm, multiply the mm/meter value by the gauge length of the sensor.

$$\text{deviation in mm} = \text{mm/meter value} \cdot \text{gauge length of sensor}$$

In this example, the gauge length is 2 meters, so the deviation would be about 70 mm. For higher accuracy, it is best to correct for changes in temperature.

Converting the thermistor reading to degrees C.

The calibration record provides an equation for converting the thermistor reading to degrees C. You need the Toffset value from the calibration record and a thermistor reading. In the equation below, ET represents the thermistor reading in volts.

$$\text{DegC} = (1264.9 \cdot ET^5 - 2836 \cdot ET^4 + 2587.6 \cdot ET^3 - 1194.2 \cdot ET^2 + 373.51 \cdot ET - 39.366) - \text{Toffset}$$

To continue with the example, we will assume that the temperature was calculated to be 19.3 degree C.

Correcting for Temperature

Changes in temperature affect both the sensitivity and the offset of the sensor. In the instructions below, the sensitivity temperature correction is called SENSTC. The offset temperature correction is called OFFSTC.

Calculating the change in temperature

Temperature corrections are based on the change in temperature (DeltaT) from Tnom.

$$\text{DeltaT} = \text{DegC} - \text{Tnom}$$

In this example, DegC is 19.3 and Tnom is 12 degrees C, so DeltaT is 7.3 degrees C.

Calculating SENSTC

The sensitivity correction is calculated as follows:

$$\text{SENSTC} = \text{S2} \cdot \text{DeltaT}^2 + \text{S1} \cdot \text{DeltaT} + \text{S0}$$

	S Factor	DeltaT	Value
S0	1		1
S1	0.00059828	7.3	0.004367
S2	0.0000068117	7.3 ²	0.000363
SENSTC =			1.00473

Calculating OFFSTC

The offset correction is calculated as follows:

$$\text{OFFSTC} = \text{F2} \cdot \text{DeltaT}^2 + \text{F1} \cdot \text{DeltaT} + \text{F0}$$

	F Factor	DeltaT	Value
F0	0.00012125		.000121
F1	0.016273	7.3	0.118793
F2	0.00096919	7.3 ²	0.051648
OFFSTC =			0.170562

Calculating the corrected mm/meter value

Corrections are applied as follows:

$$\begin{aligned} \text{corrected value} &= (\text{mm/meter value} \cdot \text{SENSTC}) + \text{OFFSTC} \\ &= (34.94903 \cdot 1.00473) + 0.170562 \\ &= 35.28491 \end{aligned}$$