

MEMS Vertical In-Place Inclinometer

57804199

Copyright ©2009 Durham Geo-Enterprises. All Rights Reserved.

This equipment should be installed, maintained, and operated by technically qualified personnel. Any errors or omissions in data, or the interpretation of data, are not the responsibility of Durham Geo-Enterprises. The information herein is subject to change without notification.

This document contains information that is proprietary to Durham Geo-Enterprises and is subject to return upon request. It is transmitted for the sole purpose of aiding the transaction of business between Durham Geo-Enterprises and the recipient. All information, data, designs, and drawings contained herein are proprietary to and the property of Durham Geo-Enterprises and may not be reproduced or copied in any form, by photocopy or any other means, including disclosure to outside parties, directly or indirectly, without permission in writing from Durham Geo-Enterprises.

SLOPE INDICATOR

12123 Harbour Reach Drive
Mukilteo, Washington, USA, 98275
Tel: 425-493-6200 Fax: 425-493-6250
E-mail: solutions@slope.com
Website: www.slopeindicator.com

Contents

Introduction	1
Preparations for Installation	4
Installation	5
Manual Readings	8
Data Reduction	9
Connection to Data Logger	14

Introduction

Vertical In-Place Inclinometers

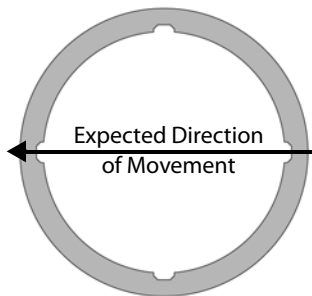

Casing should be installed with one set of grooves aligned with the expected direction of movement.

The wheels of the sensors are inserted in these grooves.

The in-place inclinometer system consists of inclinometer casing and a string of in-place inclinometer sensors.

The inclinometer casing provides access for subsurface measurements, controls the orientation of the sensors, and moves with the surrounding ground.

In vertical installations, the casing is installed in a borehole that passes through a suspected zone of movement into stable ground below. One set of grooves in the casing is aligned with the expected direction of movement, as shown in the drawing at left.

The grooves in the casing control the orientation of the in-place sensors. A stainless steel cable keeps the sensors at the required depth.

The sensors measure inclination from vertical. As ground movement occurs, the casing moves with it, changing the inclination of the sensors inside the casing.

The inclination measurements are then processed to provide displacement readings in mm or inches.

In most applications, sensors are connected to a data acquisition system and data processing is completed by a computer program.

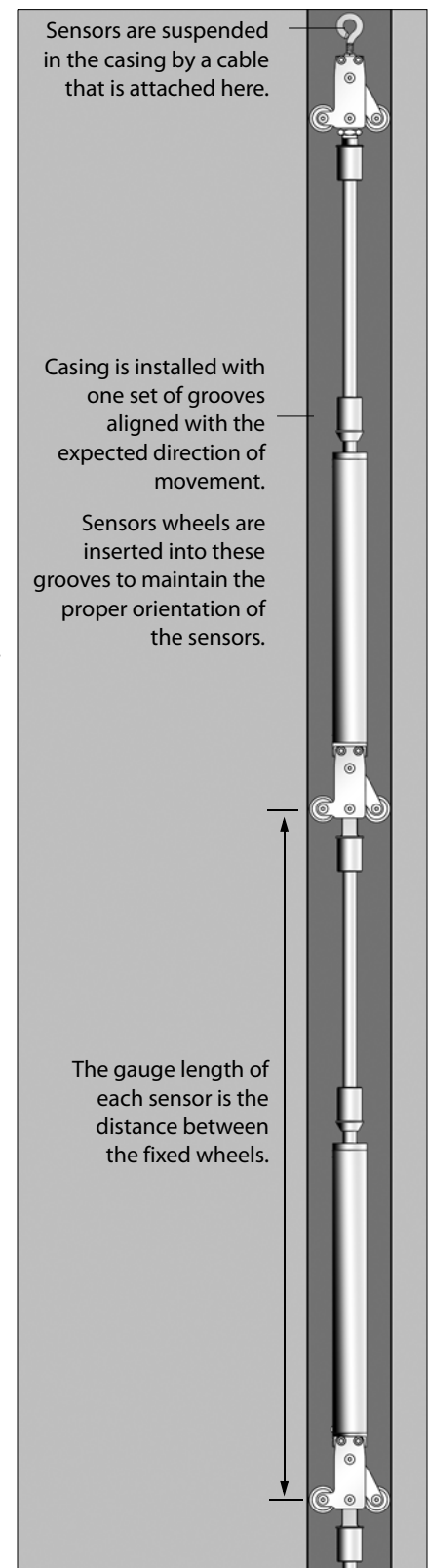

Sensors are suspended in the casing by a cable that is attached here.

Casing is installed with one set of grooves aligned with the expected direction of movement.

Sensors wheels are inserted into these grooves to maintain the proper orientation of the sensors.

The gauge length of each sensor is the distance between the fixed wheels.

Sensor Components

In-place sensors can be installed as a single sensor or as a string of linked sensors. The drawing at right shows both.

An individual sensor includes a sensor body, a gauge tube, a top wheel, and a bottom wheel.

A string of linked sensors includes n sensor bodies, n gauge tubes, a top wheel, a bottom wheel, and $n-1$ middle wheels.

Sensor bodies can contain uniaxial or biaxial sensors, but look the same.

Gauge tubes are sized to make gauge lengths of 1, 2, or 3 m (or 3, 5, and 10') when joined to a sensor body and wheels.

Top wheels have an eyelet for attaching a stainless steel suspension cable. They also have a socket for connecting to a gauge tube.

Bottom wheels attach directly to the bottom of the sensor. They have no socket.

Middle wheels are used to link sensors. The middle wheel attaches directly to the bottom of the sensor sensor and has a socket for connecting to the gauge tube from the sensor below.

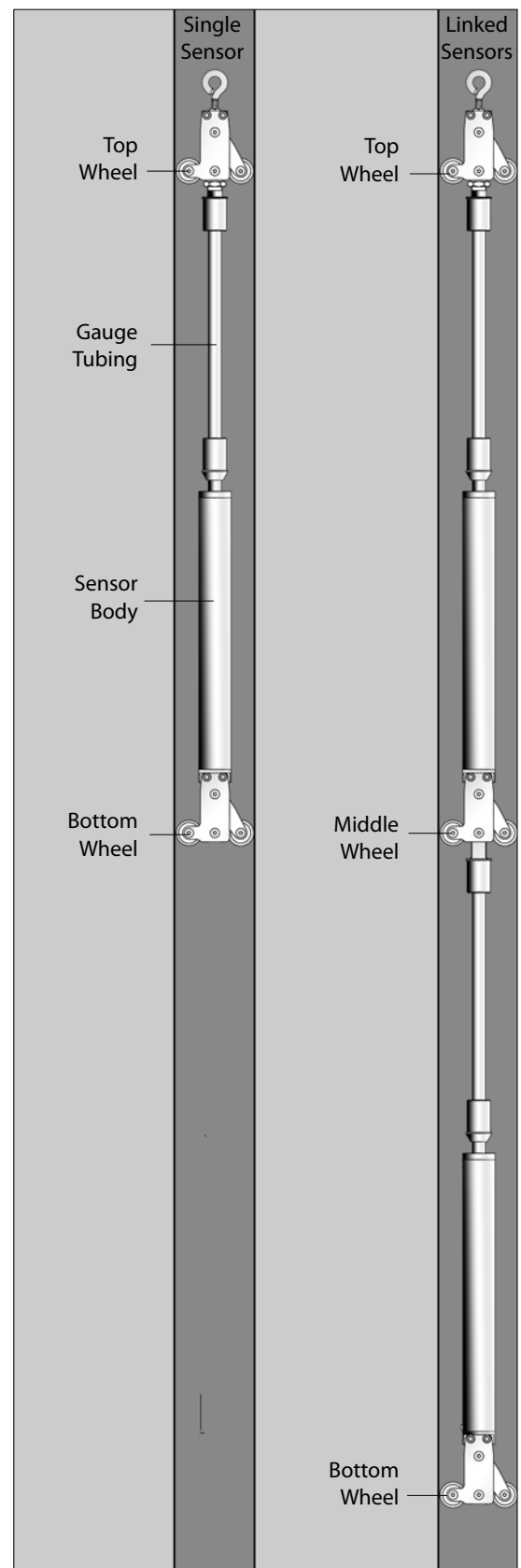

Suspension Kits

Top Suspension Kit is used to suspend the IPI sensor or string of Apia sensors from the top of the casing. Stainless steel cable is ordered separately.

In-Line Suspension Kit is used to suspend a string of deeper sensors from a string of shallower sensors. This allows economical monitoring of two or more separate zones of interest.

Safety Cable (not shown) is sometimes attached to the bottom sensor and used to prevent loss of sensors downhole during installation. A safety cable is also helpful when sensors are withdrawn from the casing.

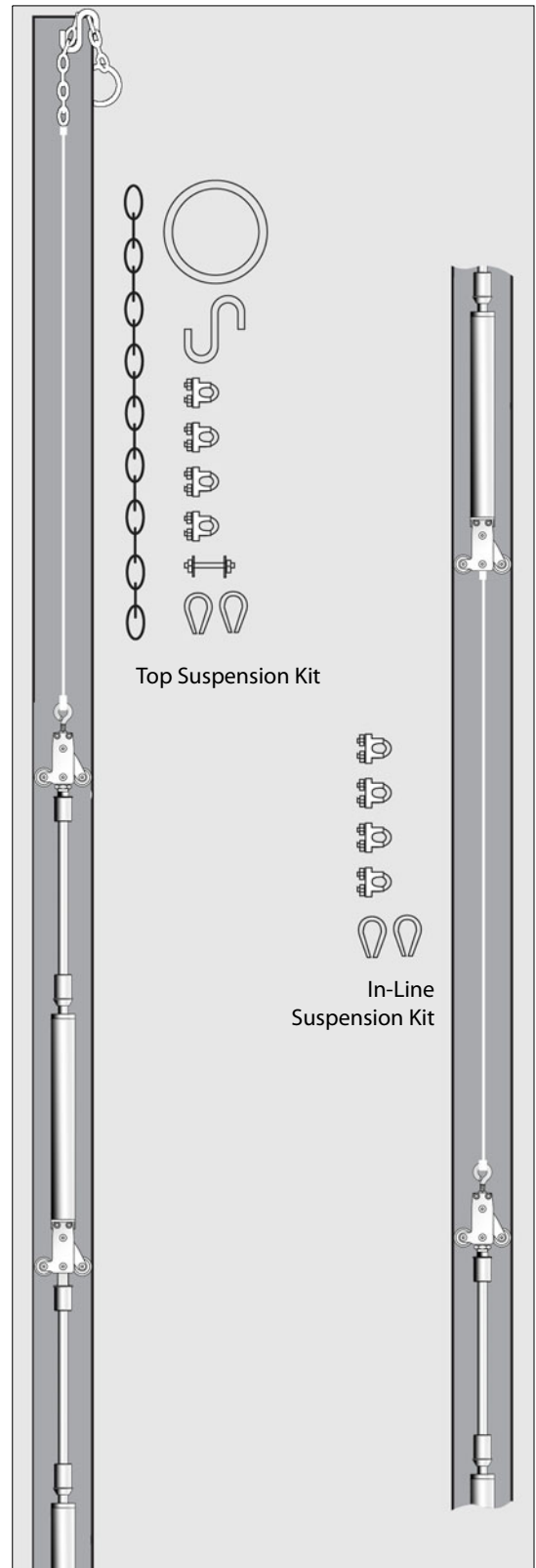

Preparations for Installation

Check Sensors

1. Check each sensor. See the “Manual Readings” for instructions.
2. Make a note of the serial number of each sensor and its intended depth of installation.
3. Check that cable lengths are correct and that each cable has an ID tag.
4. Mark sensors for order of installation.

Prepare Suspension Cable

1. Check project specifications for intended depth of top sensor.
2. Determine the required depth of the top wheels of the top sensor.
3. Determine the distance between the top wheels and the top of the casing. Cut the stainless steel suspension cable to this length.
4. Connect suspension cable to top wheel as shown in the drawing.
5. Connect suspension cable to the chain as shown in the drawing.

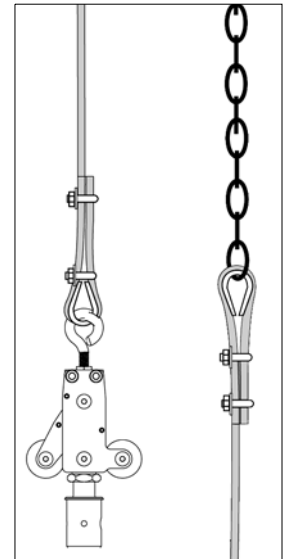

Attach Gauge Tubing

1. Remove screw from socket.
2. Align hole in gauge tube with hole in socket, then insert gauge tube into socket.
3. Insert screw and tighten to secure the gauge tube.
4. No further pre-assembly is recommended.

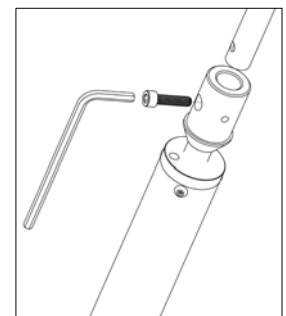

Gather Tools

- Vice grips (clamping pliers) for holding gauge tubing while connecting adjacent sensors.
- Allen wrench for screws that securing gauge tubing.
- Cable ties or vinyl tape to secure cable to gauge tubing.
- Optional: safety cable connected to bottom sensor to prevent loss of sensors down hole. The safety cable is also helpful when the sensors are withdrawn from the casing.

Installation

Installation Overview

1. Lay out sensors in order of installation.
2. Attach safety cable to first sensor (optional), then insert the first sensor into the preferred set of grooves.
3. Lower the sensor into the casing. Clamp the top of the gauge tube to hold the sensor while you connect the next sensor.
4. Align the next sensor with the preferred set of grooves as in step 2, and connect it to the gauge tubing of the downhole sensor.
5. Lower the two sensors. Repeat steps 4 and 5 until all sensors have been installed.
6. Connect the top wheel and suspension kit and lower the sensors to their final elevation.

Install the First Sensor

1. Attach safety cable to bottom sensor. Secure the safety cable. Insert first sensor in selected set of grooves. The fixed wheel should point to the expected direction of movement.
2. Secure signal cable to gauge tubing and then lower sensor into casing. Clamp the top of gauge tubing to hold it at the top of the casing.

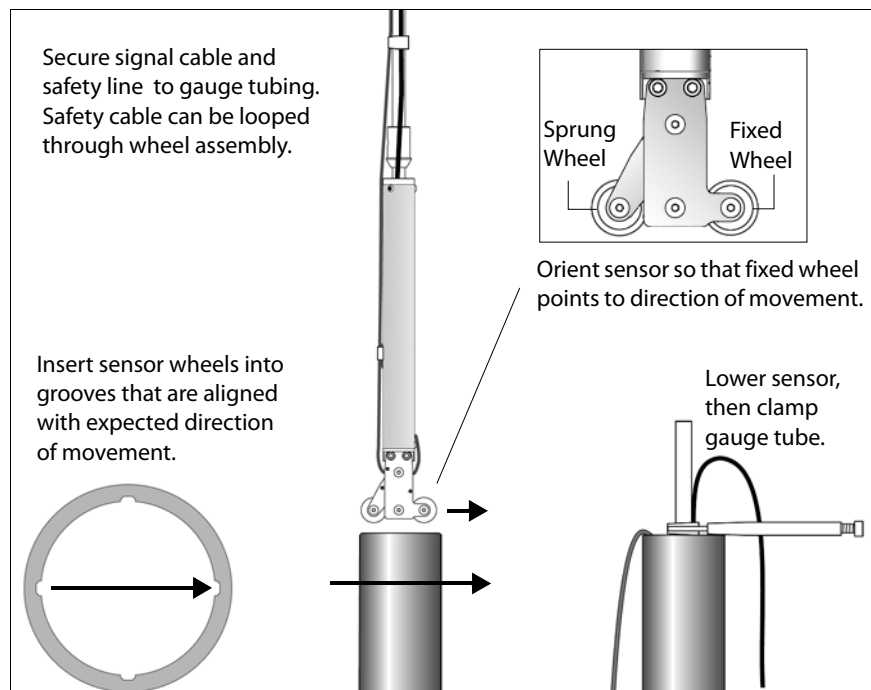

Install the Next Sensor

Connect next sensor to the gauge tubing of the sensor below, as shown in the drawing. Continue adding sensors until the sensor string is complete. Keep the following points in mind:

- Do not allow the installed sensor to twist in the casing, as this may damage the wheels or pop them out of the grooves.
- When you lower the sensor into the casing, check that the fixed wheel is aligned in the proper direction.
- Secure cables neatly, so that they do not cross each other.

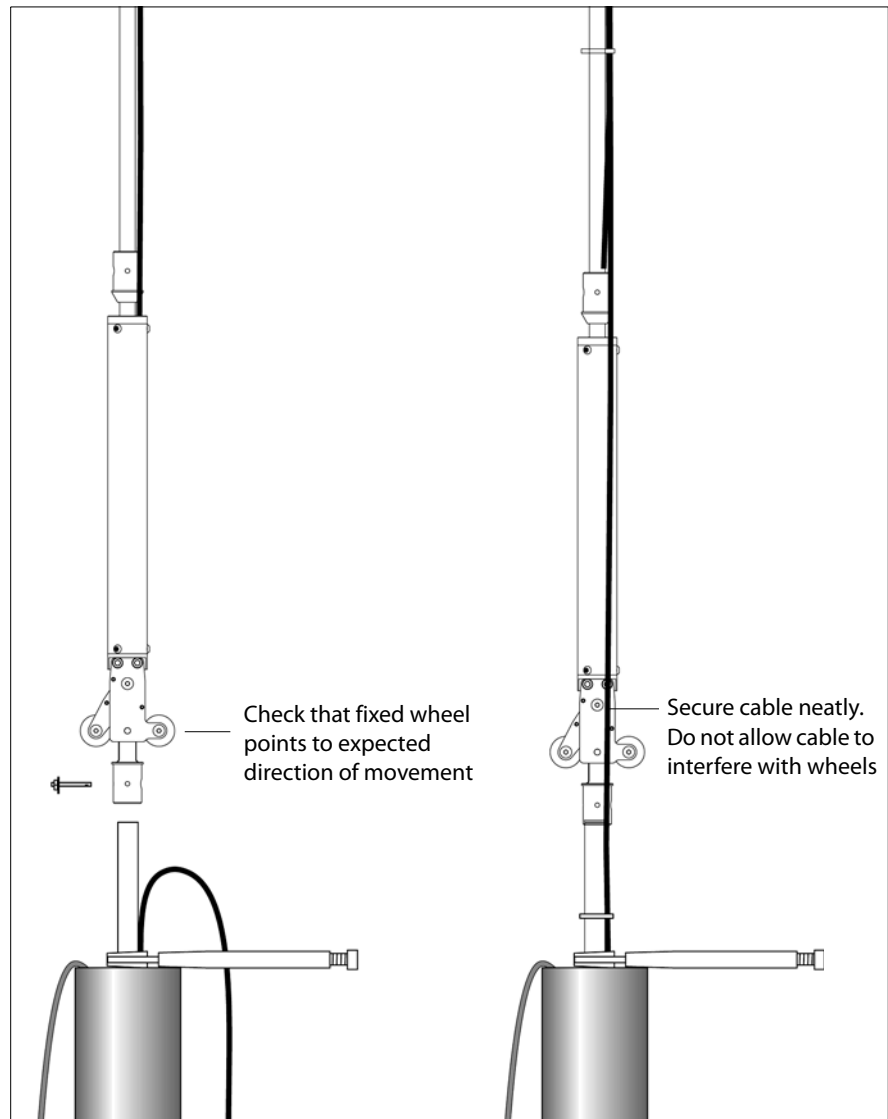

Install the Install Top Wheel

1. Connect top wheel to gauge tubing.
2. Check that suspension cable is attached securely.

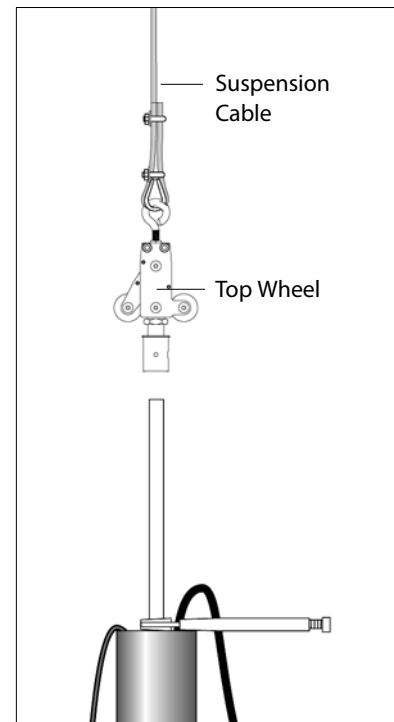

Suspend the Sensors

1. Check that suspension cable is securely clamped.
2. Use the chain and S-hook to make fine adjustments to the final depth of the sensors.

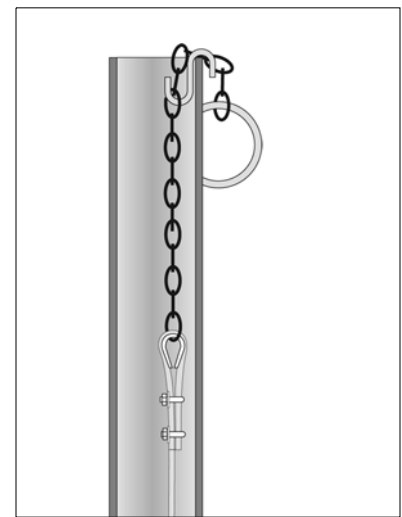

Note on Retrieving Sensors

When you withdraw the sensors, you must disassemble the string and remove sensors one at a time from the casing. Otherwise there is a good chance that sensor wheels and gauge tubes will be damaged.

1. Draw each sensor upwards.
2. Clamp the gauge tube of the sensor below
3. Disconnect the sensor, and repeat. If you intend to reinstall the sensors, check that they are still numbered for order of installation

Manual Readings

Introduction Manual readings are useful for testing the system before the data acquisition system is set up.

EL/MEMS Data Recorder

1. Connect sensor to readout as shown in the table below.
2. Switch on. Choose uniaxial or biaxial sensor.
3. Tilt is displayed in volts. Temperature is displayed in degrees C.

Data Recorder Terminal	Signal Cable Wire
1 Tilt A	Orange
2 Tilt B	Blue
3 Temp	Red
4 Sig Common	Yellow
5 Sense	Violet
6 Power +	Green
7 Power -	Black
8 Shield	Drain Wire

Test Readings

1. When the sensor body is vertical, you should see a reading of about 0.0 Vdc in both axes.
2. The A-axis sensor measures tilt in the plane of the wheels. Tilting the sensor to 10 degrees should provide a reading of ± 2.2 to 2.3 Volts. The fixed wheel points to the positive direction. See drawing on in the data reduction section.
3. The B-axis sensor (available with biaxial sensors only) is rotated 90 degrees from the A-axis sensor. Tilting the sensor to 10 degrees should provide a reading of ± 2.2 to 2.3 Volts. The plane 90 degrees clockwise from the fixed wheel is the positive direction.
4. At 25 degrees C, the thermistor reading should be about 1 Vdc.

Data Reduction

Introduction Data reduction is usually automated because it involves a large number of readings and a large number of calculations.

Here, we explain the sensor calibration record and provide an example of converting a single reading in volts to tilt in mm per meter and tilt in degrees.

Calibration Record A calibration record is provided with each sensor. Use sensor serial numbers to match sensors with their calibrations. Calibrations are unique for each sensor.

The calibration record provides two sets of factors. One set is used to convert volts to tilt in mm per meter. The other set is used to convert volts to tilt in degrees.

Factors for tilt are C0, C1, C2, and C3. A-axis factors have an A prefix: AC0, AC1, AC2, AC3. B-axis factors have a B prefix.

Factors for temperature correction are S2, S1, S0, F1, F0, and TOFF. A-axis factors have an A prefix; B-axis factors have a B prefix. TOFF is the same for both A and B and has no prefix.

Converting Volts to Tilt To convert a reading in volts to tilt, use the following formula:
Tilt = C3 * Volts³ + C2 * Volts² + C1 * Volts + C0

Where:

Tilt is a value in mm/m or degrees, depending on the factors used.

C3...C0 are factors for A-axis or B-axis.

Volts is the sensor reading in volts.

Correcting Tilt for Temperature To correct the tilt for temperature, use the following formula:
Tilt_{Corr} = (Tilt * (S2 * deltaT² + S1 * deltaT + S0) + (F1 * deltaT + F0)

Where:

Tilt is the value calculated above.

S2, S1, S0, F1, F0, and TOFF are factors from the calibration record.

deltaT is calculated as follows:

deltaT = TdegC - TOFF.

Where:

TdegC is the temperature reading from the sensor in degrees C.

Calculating Tilt in mm/m

Sensor 14384 gives an A-axis reading of 0.4137 V at 6.7°C.
The calibration record lists these factors for tilt in mm/m:

$$AC3 = -2.0071E-003$$

$$AC2 = -7.1668E-002$$

$$AC1 = 7.9535E+001$$

$$AC0 = 1.3865E+000$$

$$\text{Tilt} = C3 * \text{Volts}^3 + C2 * \text{Volts}^2 + C1 * \text{Volts} + C0$$

$$\text{Tilt} = -2.0071E-3 * 0.4137^3 + -7.1668E-2 * 0.4137^2 + 7.9535E+1 * 0.4137 + 1.3865$$

$$\text{Tilt} = 34.278 \text{ mm/m}$$

Temperature Correction

The calibration record lists these temperature correction factors for tilt
in mm/m:

$$AS2 = 5.7354E-008$$

$$AS1 = 1.4840E-004$$

$$AS0 = 10.0000E-001$$

$$AF1 = 2.2831E-003$$

$$AF0 = 1.6233E-002$$

$$\text{TOFF} = 14.6$$

$$\text{deltaT} = \text{TdegC} - \text{TOFF}$$

$$\text{deltaT} = 6.7 - 14.6$$

$$\text{deltaT} = -7.9$$

$$\text{Tilt}_{\text{Corrected}} = (\text{Tilt} \times (S2 * \text{deltaT}^2 + S1 * \text{deltaT} + S0)) + (F1 * \text{deltaT} + F0)$$

$$\text{Tilt}_{\text{Corrected}} = (34.278 * (5.7354E-8 * -7.92 + 1.4840E-4 * -7.9 + 10.0000E-1)) + \\ (2.2831E-3 * -7.9 + 1.6233E-2)$$

$$\text{Tilt}_{\text{Corrected}} = 34.236 \text{ mm/m}$$

Calculating Tilt in Degrees

Sensor 14384 gives an A-axis reading of 0.4137 V at 6.7°C. The calibration record for sensor 14384 lists these factors for tilt in degrees:

$$AC3_D = 4.7710E-003$$

$$AC2_D = -3.9139E-003$$

$$AC1_D = 4.5569E+000$$

$$AC0_D = 7.9473E-002$$

$$\text{Tilt} = C3 * \text{Volts}^3 + C2 * \text{Volts}^2 + C1 * \text{Volts} + C0$$

$$\text{Tilt} = 4.7710E-3 * 0.4137^3 + -3.9139E-3 * 0.4137^2 + 4.5569 * 0.4137 + 7.9473E-2$$

$$\text{Tilt} = 1.9643 \text{ degrees}$$

Temperature Correction

The calibration record for sensor 14384 lists these temperature correction factors for tilt in degrees:

$$AS2_D = 6.0488E-008$$

$$AS1_D = 1.4948E-004$$

$$AS0_D = 10.0000E-001$$

$$AF1_D = 1.3175E-004$$

$$AF0_D = 9.3593E-004$$

$$\text{TOFF} = 14.6$$

$$\text{deltaT} = \text{TdegC} - \text{TOFF}$$

$$\text{deltaT} = 6.7 - 14.6$$

$$\text{deltaT} = -7.9$$

$$\text{Tilt}_{\text{Corrected}} = (\text{Tilt} * (S2 * \text{deltaT}^2 + S1 * \text{deltaT} + S0)) + (F1 * \text{deltaT} + F0)$$

$$\text{Tilt}_{\text{Corrected}} = (1.9643 * (6.0488E-8 * -7.9^2 + 1.4948E-4 * -7.9 + 10.0000E-1)) + (1.3175E-4 * -7.9 + 9.3593E-4)$$

$$\text{Tilt}_{\text{Corrected}} = 1.9619 \text{ degrees}$$

Calculating Deviation

To calculate deviation over the gauge length of the sensor, use either formula below:

$$\text{Deviation}_{\text{mm}} = \text{Tilt}_{\text{mm/m}} * \text{gauge_length}_{\text{m}}$$

or

$$\text{Deviation}_{\text{mm}} = \sin(\text{Tilt}_{\text{deg}}) * \text{gauge_length}_{\text{mm}}$$

Example: Sensor 14384 has a gauge length of 2 meters. The examples below use the temperature corrected tilt values.

$$\text{Deviation}_{\text{mm}} = 34.236 \text{ mm/m} * 2 \text{ m}$$

$$\text{Deviation}_{\text{mm}} = 68.472$$

$$\text{Deviation}_{\text{mm}} = \sin(1.9619) * 2000 \text{ mm}$$

$$\text{Deviation}_{\text{mm}} = 68.469$$

Calculating Displacement

Displacement (movement) is the change in deviation:

$$\text{Displacement} = \text{Deviation}_{\text{current}} - \text{Deviation}_{\text{initial}}$$

Direction of Tilt & Displacement

Uniaxial sensors respond to tilt in the plane parallel to the wheels of the sensor. This plane is called the A axis. A-axis readings may be positive or negative. Positive readings indicate that the sensor is tilted in the direction of the fixed wheel. Negative readings indicate that the sensor is tilted in the direction of the sprung wheel.

Biaxial sensors respond to tilt in the plane of the wheels (A-axis) and the plane rotated 90 degrees to the wheels (B-axis). Positive A-axis readings show tilt in the direction of the fixed wheels. Positive B-axis readings show tilt in the direction rotated 90 degrees clockwise. Displacement directions follow the same convention. In the drawing below, the sensor is viewed from the top.

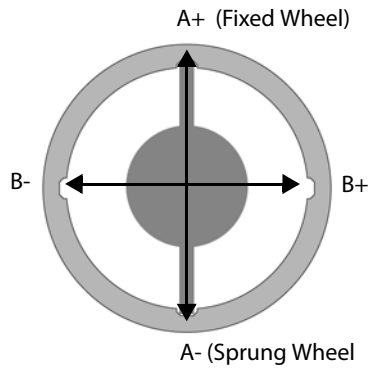

Connection to Data Loggers

CR10X or CR1000 These instructions provide information needed for reading uniaxial and biaxial IPIs with the Campbell Scientific CR1000 datalogger system.

Sample Program: A sample CR1000 monitoring program is available at the Slope Indicator website. Go to www.slopeindicator.com. Then navigate to Support -> TechNotes -> DataLoggers, and look for sample programs.

Wiring Diagrams: The wiring diagrams on the following pages show how to connect uniaxial and biaxial IPIs to the Campbell Scientific CR1000 datalogger system.

Wiring Diagram 1 Uniaxial sensor connected directly to CR1000

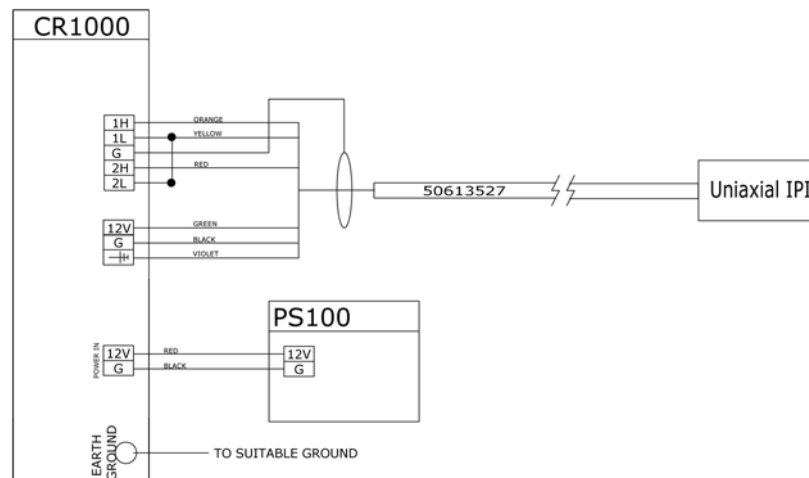

Wiring Diagram 2 Biaxial sensor connected directly to CR1000

