

# **MEMS Vertical IPI Serial Sensors**

**57804599**

Copyright ©2009 Durham Geo-Enterprises. All Rights Reserved.

This equipment should be installed, maintained, and operated by technically qualified personnel. Any errors or omissions in data, or the interpretation of data, are not the responsibility of Durham Geo-Enterprises. The information herein is subject to change without notification.

This document contains information that is proprietary to Durham Geo-Enterprises and is subject to return upon request. It is transmitted for the sole purpose of aiding the transaction of business between Durham Geo-Enterprises and the recipient. All information, data, designs, and drawings contained herein are proprietary to and the property of Durham Geo-Enterprises and may not be reproduced or copied in any form, by photocopy or any other means, including disclosure to outside parties, directly or indirectly, without permission in writing from Durham Geo-Enterprises.

## *SLOPE INDICATOR*

12123 Harbour Reach Drive  
Mukilteo, Washington, USA, 98275  
Tel: 425-493-6200 Fax: 425-493-6250  
E-mail: [solutions@slope.com](mailto:solutions@slope.com)  
Website: [www.slopeindicator.com](http://www.slopeindicator.com)

---

# Contents

Introduction.....	1
Preparations for Installation .....	5
Installation .....	6
Data Reduction.....	10
Connection to Data Logger .....	15

# Introduction

## Vertical In-Place Inclinometers

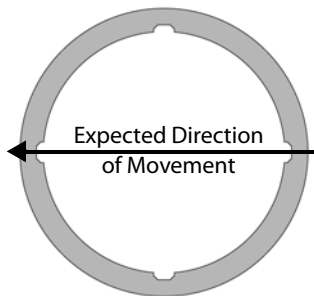

Casing should be installed with one set of grooves aligned with the expected direction of movement.

The wheels of the sensors are inserted in these grooves.

The in-place inclinometer system consists of inclinometer casing and a string of in-place inclinometer sensors.

The inclinometer casing provides access for subsurface measurements, controls the orientation of the sensors, and moves with the surrounding ground.

In vertical installations, the casing is installed in a borehole that passes through a suspected zone of movement into stable ground below. One set of grooves in the casing is aligned with the expected direction of movement, as shown in the drawing at left.

The grooves in the casing control the orientation of the in-place sensors. A stainless steel cable keeps the sensors at the required depth.

The sensors measure inclination from vertical. As ground movement occurs, the casing moves with it, changing the inclination of the sensors inside the casing.

The inclination measurements are then processed to provide displacement readings in mm or inches.

In most applications, sensors are connected to a data acquisition system and data processing is completed by a computer program.

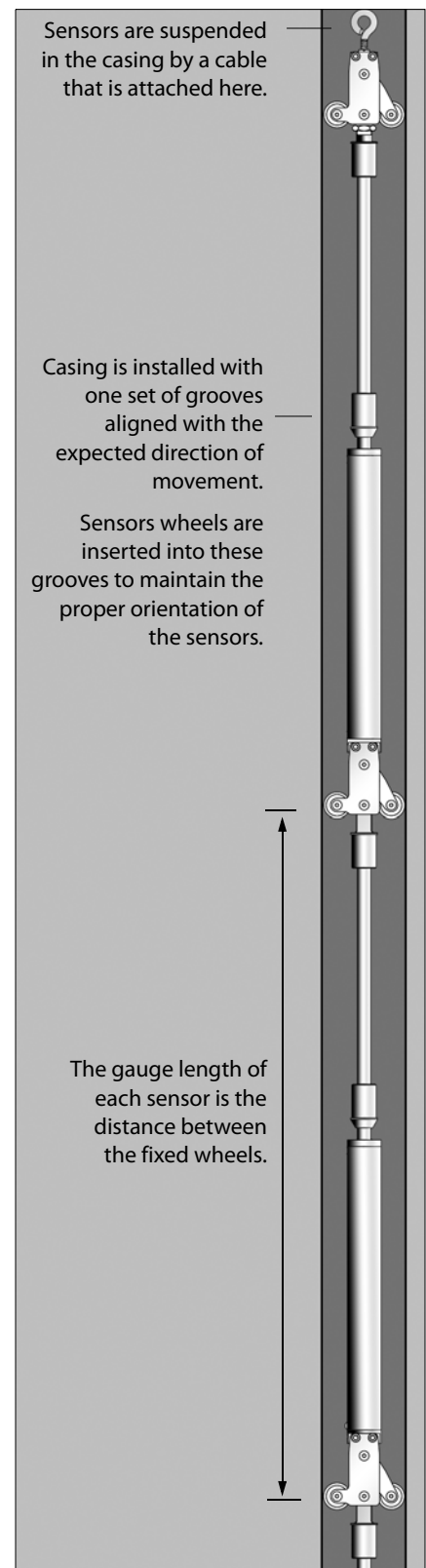

## Sensor Components

In-place sensors can be installed as a single sensor or as a string of linked sensors. The drawing at right shows both.

An individual sensor includes a sensor body, a gauge tube, a top wheel, and a bottom wheel.

A string of linked sensors includes  $n$  sensor bodies,  $n$  gauge tubes, a top wheel, a bottom wheel, and  $n-1$  middle wheels.

**Sensor bodies** can contain uniaxial or biaxial sensors, but look the same.

**Gauge tubes** are sized to make gauge lengths of 1, 2, or 3 m (or 3, 5, and 10') when joined to a sensor body and wheels.

**Top wheels** have an eyelet for attaching a stainless steel suspension cable. They also have a socket for connecting to a gauge tube.

**Bottom wheels** attach directly to the bottom of the sensor. They have no socket.

**Middle wheels** are used to link sensors. The middle wheel attaches directly to the bottom of the sensor sensor and has a socket for connecting to the gauge tube from the sensor below.

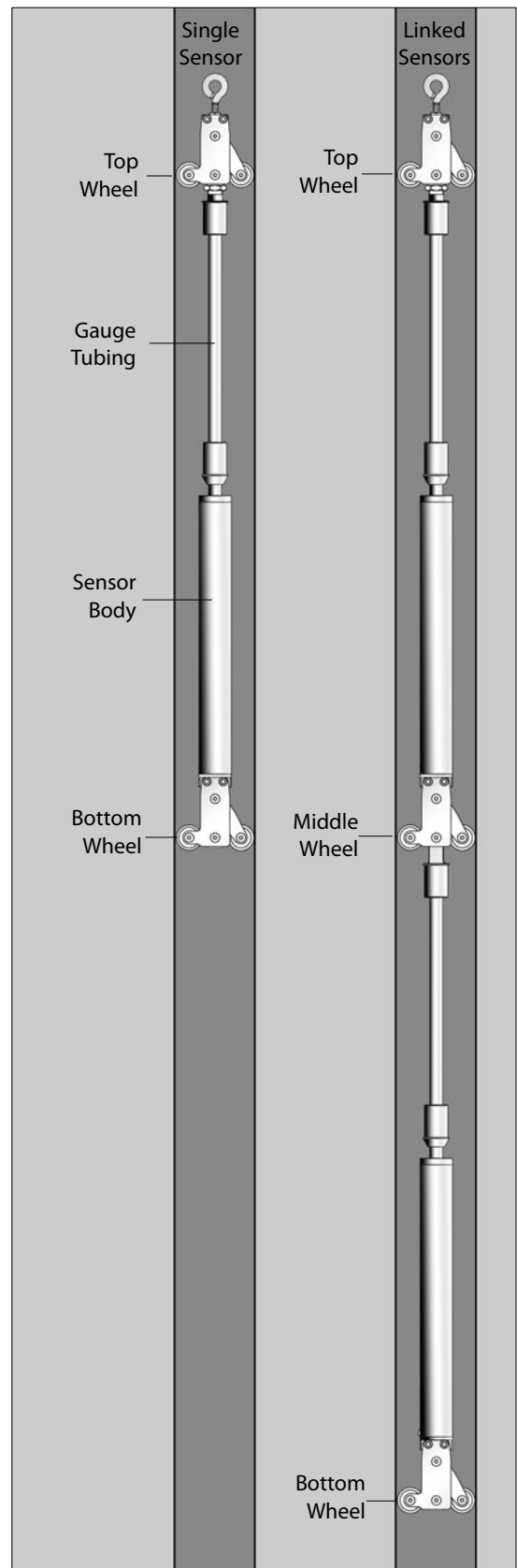

## Serial Sensor Cable Connections

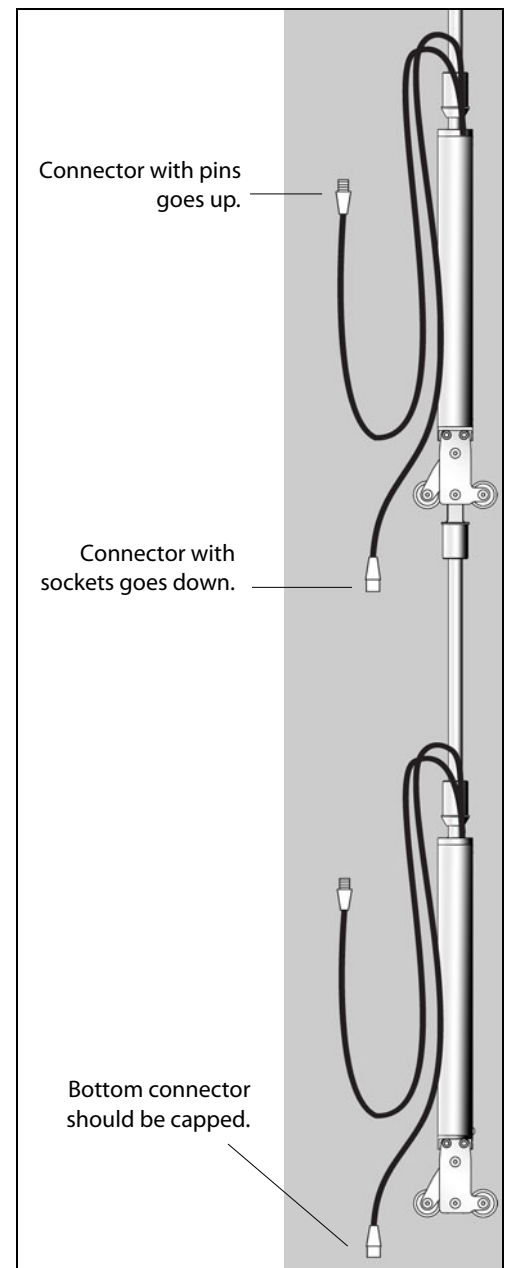

## Other Components

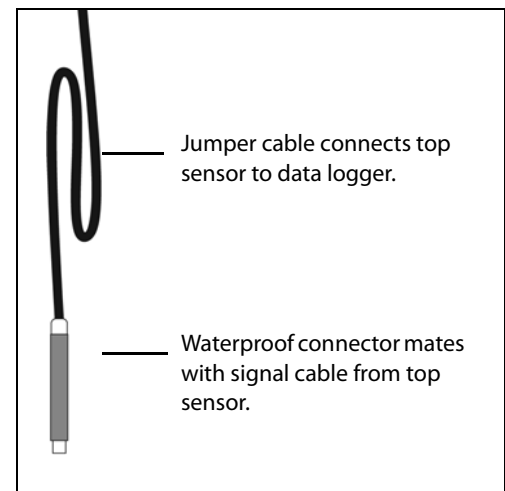

## Suspension Kits

**Top Suspension Kit** is used to suspend the IPI sensors from the top of the casing. Stainless steel cable is ordered separately.

**In-Line Suspension Kit** is used to suspend a string of deeper sensors from a string of shallower sensors. This allows economical monitoring of two or more separate zones of interest.

**Safety Cable** (not shown) is sometimes attached to the bottom sensor and used to prevent loss of sensors downhole during installation. A safety cable is also helpful when sensors are withdrawn from the casing.

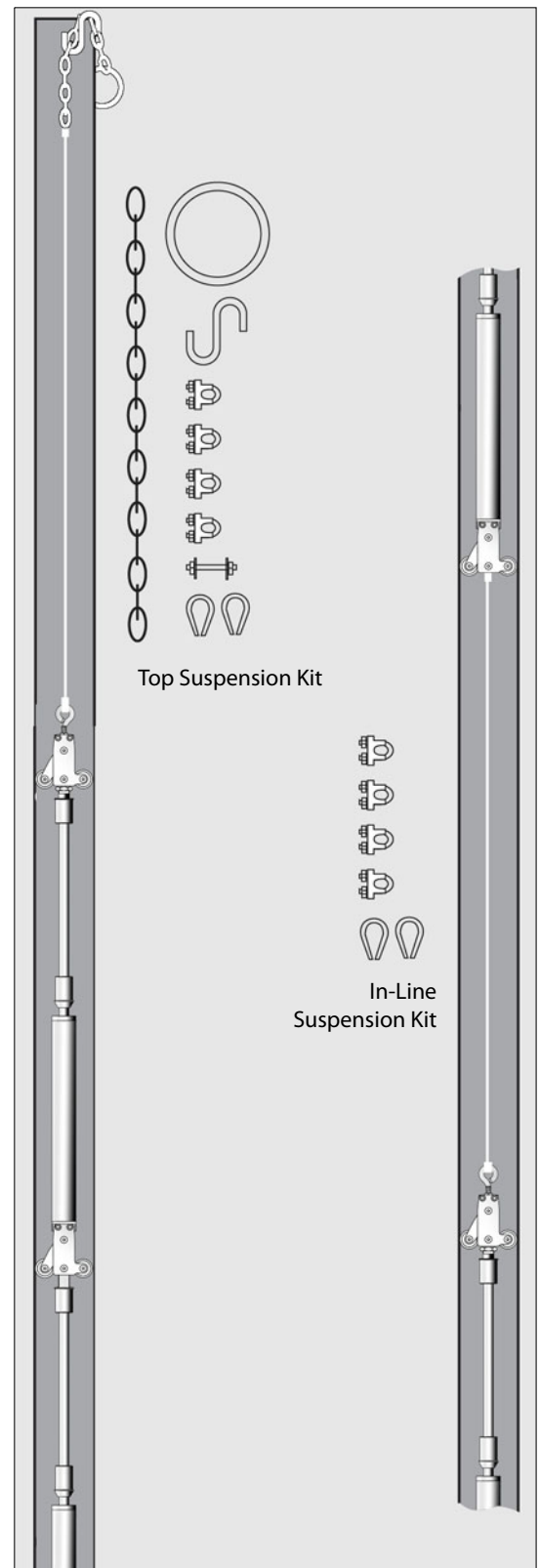

---

# Preparations for Installation

## Check Sensors

1. Check each sensor.
2. Identify the bottom sensor for each string. The bottom sensor will require a plug for the bottom connector.
3. Make a note of the serial number of each sensor and its intended depth of installation.
4. Mark sensors for order of installation.
5. Check length of jumper cable to make sure it will run from the top sensor to the datalogger.

## Prepare Suspension Cable

1. Check project specifications for intended depth of top sensor.
2. Determine the required depth of the top wheels of the top sensor.
3. Determine the distance between the top wheels and the top of the casing. Cut the stainless steel suspension cable to this length.
4. Connect suspension cable to top wheel as shown in the drawing.
5. Connect suspension cable to the chain as shown in the drawing.

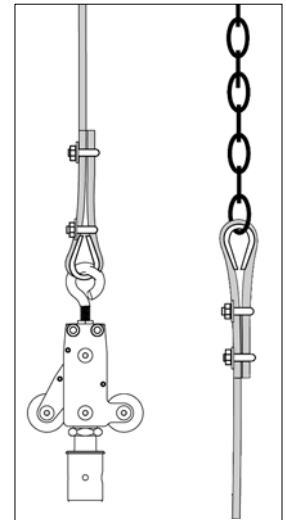

## Attach Gauge Tubing

1. Remove screw from socket.
2. Align hole in gauge tube with hole in socket, then insert gauge tube into socket.
3. Insert screw and tighten to secure the gauge tube.
4. No further pre-assembly is recommended.

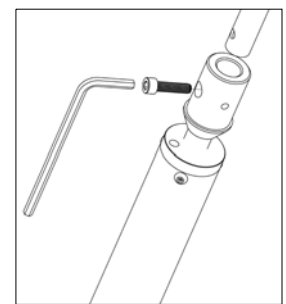

## Gather Tools

- Vice grips (clamping pliers) for holding gauge tubing while connecting adjacent sensors.
- Allen wrench for screws that securing gauge tubing.
- Cable ties or vinyl tape to secure cable to gauge tubing.
- Optional: safety cable connected to bottom sensor to prevent loss of sensors down hole. The safety cable is also helpful when the sensors are withdrawn from the casing.

---

# Installation

## Installation Overview

1. Lay out sensors in order of installation.
2. Insert the first sensor into the preferred set of grooves.
3. Lower the sensor into the casing. Clamp the top of the gauge tube to hold the sensor while you connect the next sensor.
4. Align the next sensor with the preferred set of grooves as in step 2, and connect it to the gauge tubing of the downhole sensor.
5. Lower the two sensors. Repeat steps 4 and 5 until all sensors have been installed.
6. Connect the top wheel and suspension kit and lower the sensors to their final elevation.

## Install the First Sensor

1. Check that bottom connector of first sensor is capped.
2. Optional: Attach safety cable to wheel assembly.
3. Insert first sensor in selected set of grooves. The fixed wheel should point to the expected direction of movement.
4. Secure signal cable to gauge tubing and then lower sensor into casing. Clamp the top of gauge tubing to hold it at the top of the casing.

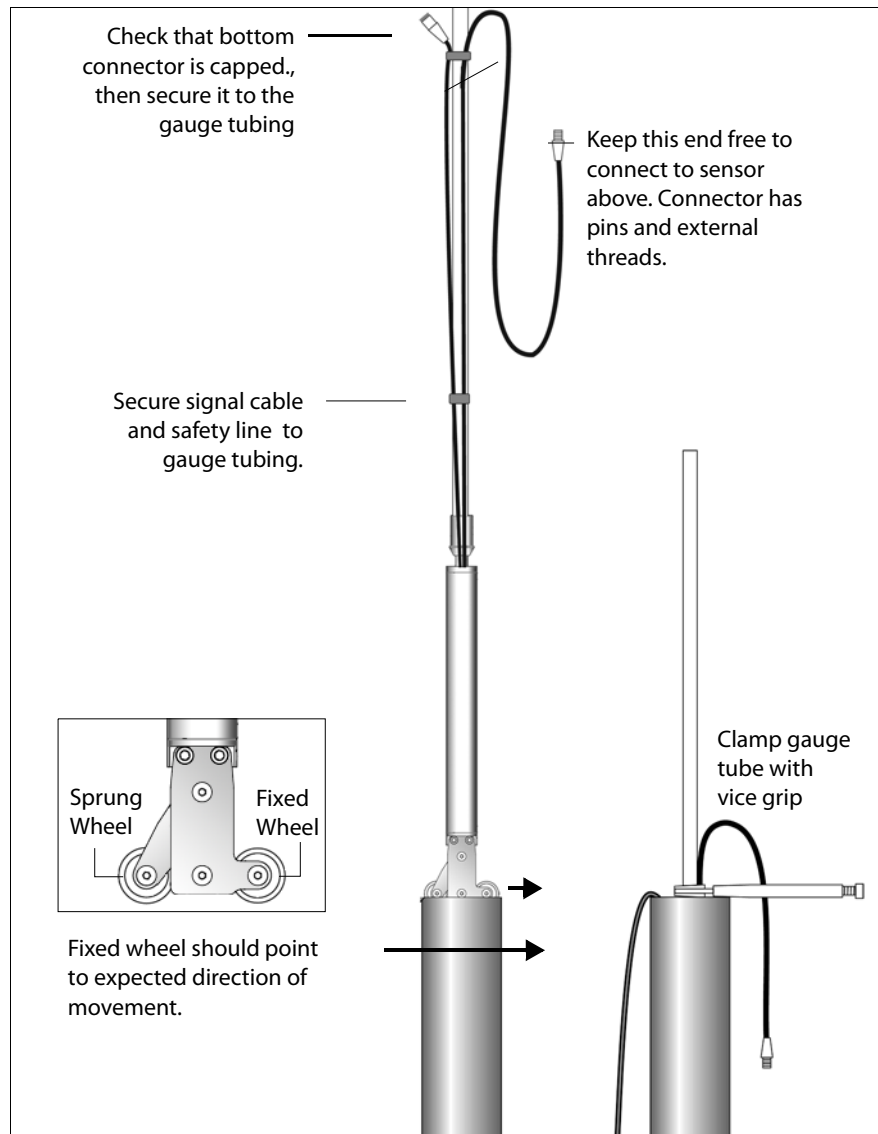

## Install Additional Sensors

1. Check that connectors are clean, then make connection. Secure excess cable to the gauge tubing with tape or a cable tie.
2. Connect next sensor to the gauge tubing of the sensor below. Always check that fixed wheel points to expected direction of movement.
3. Continue adding sensors until the sensor string is complete.

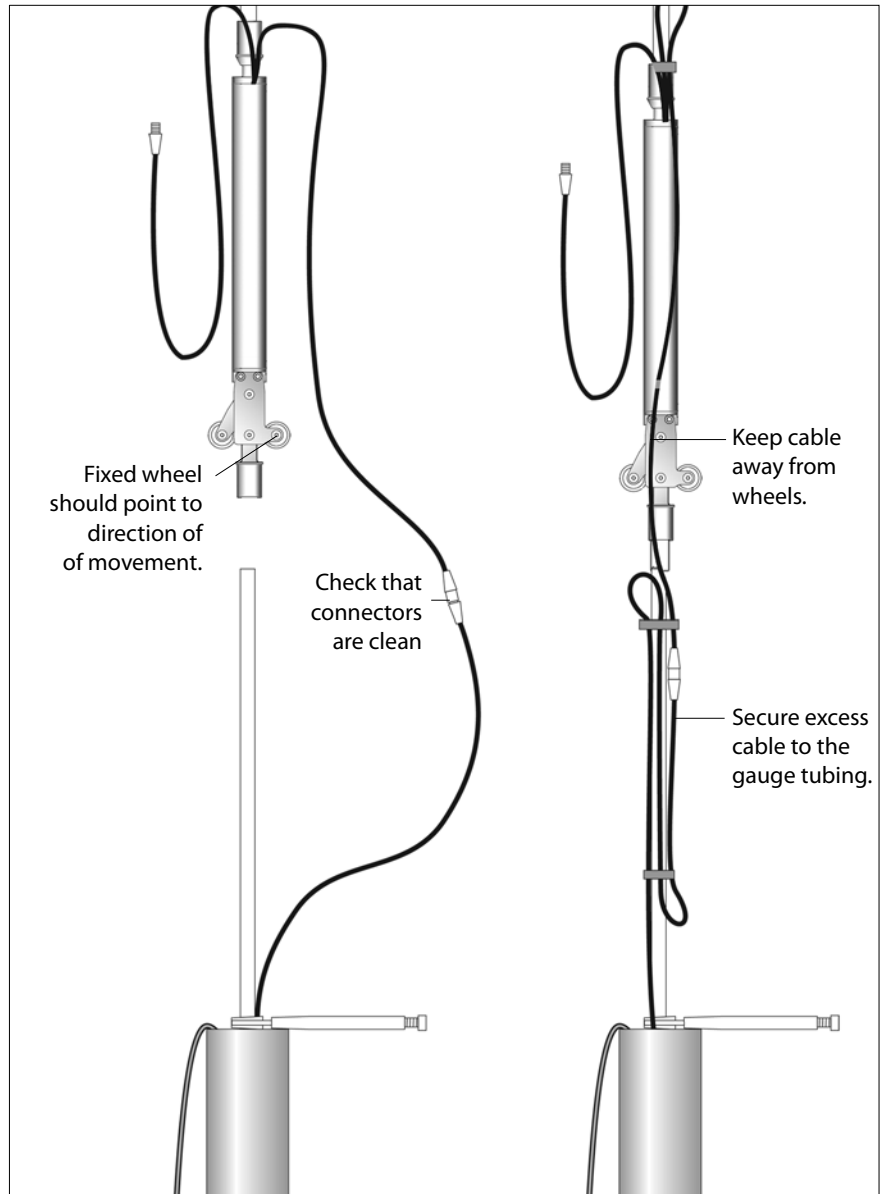

## Install the Install Top Wheel

1. Connect jumper cable to top sensor. Cable runs from top sensor to data logger.
2. Connect top wheel to gauge tube.

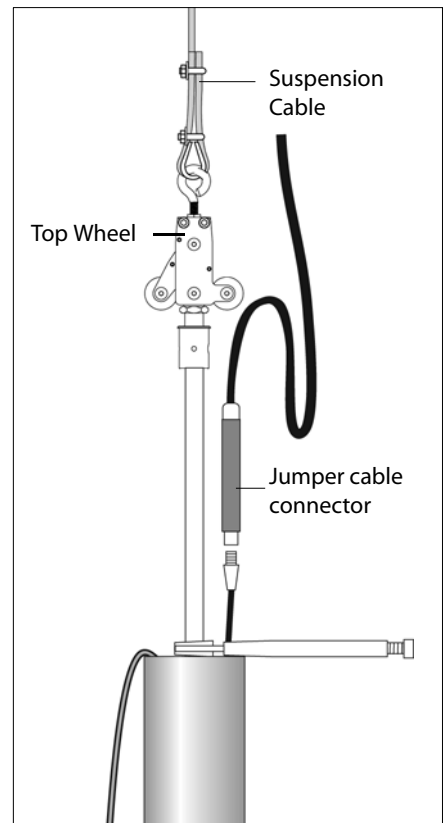

## Suspend the Sensors

1. Check that suspension cable is securely clamped.
2. Use the chain and S-hook to make fine adjustments to the final depth of the sensors.



## Note on Retrieving Sensors

Withdraw the sensors one by one rather than trying to pull out the entire chain. If you try to extract the entire chain at once, you bend gauge tubes and wheels.

1. Draw each sensor upwards.
2. Clamp the gauge tube of the sensor below
3. Disconnect the sensor, and repeat. If you intend to reinstall the sensors, check that they are still numbered for order of installation

---

# Data Reduction

**Introduction** Data reduction is usually automated because it involves a large number of readings and a large number of calculations.

Here, we explain the sensor calibration record and provide an example of converting a single reading in volts to tilt in mm per meter and tilt in degrees.

**Calibration Record** A calibration record is provided with each sensor. Use sensor serial numbers to match sensors with their calibrations. Calibrations are unique for each sensor.

The calibration record provides two sets of factors. One set is used to convert volts to tilt in mm per meter. The other set is used to convert volts to tilt in degrees.

Factors for tilt are C0, C1, C2, and C3. A-axis factors have an A prefix: AC0, AC1, AC2, AC3. B-axis factors have a B prefix.

Factors for temperature correction are S2, S1, S0, F1, F0, and TOFF. A-axis factors have an A prefix; B-axis factors have a B prefix. TOFF is the same for both A and B and has no prefix.

**Converting Volts to Tilt** To convert a reading in volts to tilt, use the following formula:  
**Tilt = C3 \* Volts<sup>3</sup> + C2 \* Volts<sup>2</sup> + C1 \* Volts + C0**

Where:

Tilt is a value in mm/m or degrees, depending on the factors used.

C3...C0 are factors for A-axis or B-axis.

Volts is the sensor reading in volts.

**Correcting Tilt for Temperature** To correct the tilt for temperature, use the following formula:  
**Tilt<sub>Corr</sub> = (Tilt \* (S2 \* deltaT<sup>2</sup> + S1 \* deltaT + S0) + (F1 \* deltaT + F0)**

Where:

Tilt is the value calculated above.

S2, S1, S0, F1, F0, and TOFF are factors from the calibration record.

deltaT is calculated as follows:

**deltaT = TdegC - TOFF.**

Where:

TdegC is the temperature reading from the sensor in degrees C.

---

## Calculating Tilt in mm/m

Sensor 14384 gives an A-axis reading of 0.4137 V at 6.7°C.  
The calibration record lists these factors for tilt in mm/m:

$$AC3 = -2.0071E-003$$

$$AC2 = -7.1668E-002$$

$$AC1 = 7.9535E+001$$

$$AC0 = 1.3865E+000$$

$$\text{Tilt} = C3 * \text{Volts}^3 + C2 * \text{Volts}^2 + C1 * \text{Volts} + C0$$

$$\text{Tilt} = -2.0071E-3 * 0.4137^3 + -7.1668E-2 * 0.4137^2 + 7.9535E+1 * 0.4137 + 1.3865$$

$$\text{Tilt} = 34.278 \text{ mm/m}$$

## Temperature Correction

The calibration record lists these temperature correction factors for tilt  
in mm/m:

$$AS2 = 5.7354E-008$$

$$AS1 = 1.4840E-004$$

$$AS0 = 10.0000E-001$$

$$AF1 = 2.2831E-003$$

$$AF0 = 1.6233E-002$$

$$\text{TOFF} = 14.6$$

$$\text{deltaT} = \text{TdegC} - \text{TOFF}$$

$$\text{deltaT} = 6.7 - 14.6$$

$$\text{deltaT} = -7.9$$

$$\text{Tilt}_{\text{Corrected}} = (\text{Tilt} \times (S2 * \text{deltaT}^2 + S1 * \text{deltaT} + S0)) + (F1 * \text{deltaT} + F0)$$

$$\text{Tilt}_{\text{Corrected}} = (34.278 * (5.7354E-8 * -7.92 + 1.4840E-4 * -7.9 + 10.0000E-1)) + (2.2831E-3 * -7.9 + 1.6233E-2)$$

$$\text{Tilt}_{\text{Corrected}} = 34.236 \text{ mm/m}$$

---

## Calculating Tilt in Degrees

Sensor 14384 gives an A-axis reading of 0.4137 V at 6.7°C. The calibration record for sensor 14384 lists these factors for tilt in degrees:

$$AC3\_D = 4.7710E-003$$

$$AC2\_D = -3.9139E-003$$

$$AC1\_D = 4.5569E+000$$

$$AC0\_D = 7.9473E-002$$

$$\text{Tilt} = C3 * \text{Volts}^3 + C2 * \text{Volts}^2 + C1 * \text{Volts} + C0$$

$$\text{Tilt} = 4.7710E-3 * 0.4137^3 + -3.9139E-3 * 0.4137^2 + 4.5569 * 0.4137 + 7.9473E-2$$

$$\text{Tilt} = 1.9643 \text{ degrees}$$

## Temperature Correction

The calibration record for sensor 14384 lists these temperature correction factors for tilt in degrees:

$$AS2\_D = 6.0488E-008$$

$$AS1\_D = 1.4948E-004$$

$$AS0\_D = 10.0000E-001$$

$$AF1\_D = 1.3175E-004$$

$$AF0\_D = 9.3593E-004$$

$$\text{TOFF} = 14.6$$

$$\text{deltaT} = \text{TdegC} - \text{TOFF}$$

$$\text{deltaT} = 6.7 - 14.6$$

$$\text{deltaT} = -7.9$$

$$\text{Tilt}_{\text{Corrected}} = (\text{Tilt} * (S2 * \text{deltaT}^2 + S1 * \text{deltaT} + S0)) + (F1 * \text{deltaT} + F0)$$

$$\text{Tilt}_{\text{Corrected}} = (1.9643 * (6.0488E-8 * -7.9^2 + 1.4948E-4 * -7.9 + 10.0000E-1)) + (1.3175E-4 * -7.9 + 9.3593E-4)$$

$$\text{Tilt}_{\text{Corrected}} = 1.9619 \text{ degrees}$$

---

## Calculating Deviation

To calculate deviation over the gauge length of the sensor, use either formula below:

$$\text{Deviation}_{\text{mm}} = \text{Tilt}_{\text{mm/m}} * \text{gauge\_length}_{\text{m}}$$

or

$$\text{Deviation}_{\text{mm}} = \sin(\text{Tilt}_{\text{deg}}) * \text{gauge\_length}_{\text{mm}}$$

**Example:** Sensor 14384 has a gauge length of 2 meters. The examples below use the temperature corrected tilt values.

$$\text{Deviation}_{\text{mm}} = 34.236 \text{ mm/m} * 2 \text{ m}$$

$$\text{Deviation}_{\text{mm}} = 68.472$$

$$\text{Deviation}_{\text{mm}} = \sin(1.9619) * 2000 \text{ mm}$$

$$\text{Deviation}_{\text{mm}} = 68.469$$

## Calculating Displacement

Displacement (movement) is the change in deviation:

$$\text{Displacement} = \text{Deviation}_{\text{current}} - \text{Deviation}_{\text{initial}}$$

## Direction of Tilt & Displacement

Uniaxial sensors respond to tilt in the plane parallel to the wheels of the sensor. This plane is called the A axis. A-axis readings may be positive or negative. Positive readings indicate that the sensor is tilted in the direction of the fixed wheel. Negative readings indicate that the sensor is tilted in the direction of the sprung wheel.

Biaxial sensors respond to tilt in the plane of the wheels (A-axis) and the plane rotated 90 degrees to the wheels (B-axis). Positive A-axis readings show tilt in the direction of the fixed wheels. Positive B-axis readings show tilt in the direction rotated 90 degrees clockwise. Displacement directions follow the same convention. In the drawing below, the sensor is viewed from the top.

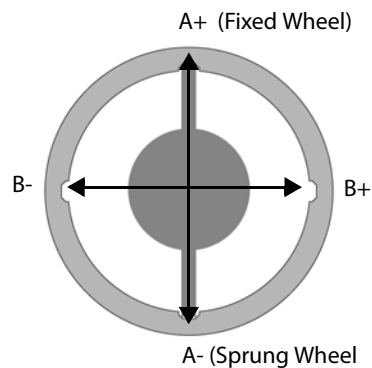

# Connection to Data Loggers

**CR10X or CR1000** These instructions provide information needed for reading uniaxial and biaxial IPIs with the Campbell Scientific CR1000 datalogger system.

**Sample Program:** A sample CR1000 monitoring program is available at the Slope Indicator website. Go to [www.slopeindicator.com](http://www.slopeindicator.com). Then navigate to Support -> TechNotes -> DataLoggers, and look for sample programs.

**Wiring Diagrams:** The wiring diagram below shows how to connect serial IPIs to the Campbell Scientific CR1000 datalogger. Uniaxial and Biaxial connections are identical.

Wiring Diagram

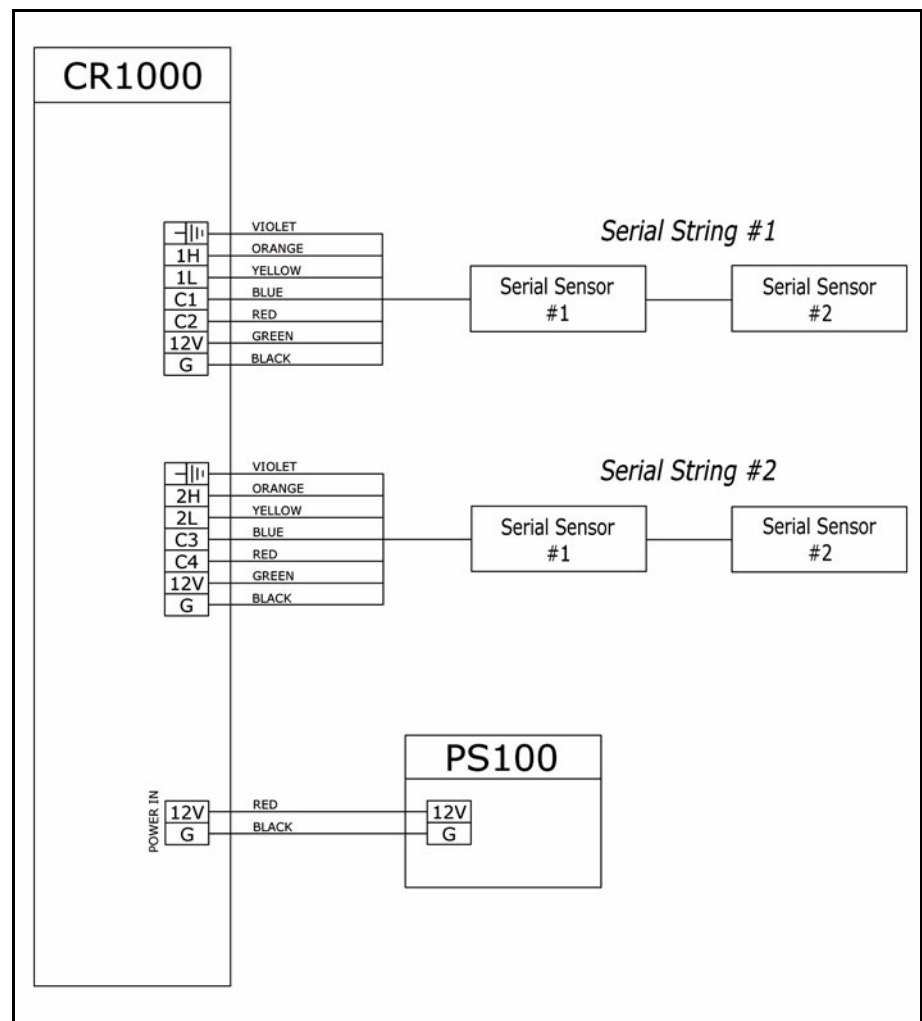

---

**Limitations** The last sensor in the chain must receive 8 volts. This limits the number of serial sensors that can be connected. the following table assumes that the logger supplies 12 volts:

Length of Jumper Cable:	Limit to Sensors in the Chain:
1 m	16 sensors
50 m	13 sensors
100 m	9 sensors
150 m	6 sensors
200 m	4 sensors
300 m	3 sensors
800 m	1 sensors