

MEMS Tiltmeter

57803199

Copyright ©2009 DGSi. All Rights Reserved.

This equipment should be installed, maintained, and operated by technically qualified personnel. Any errors or omissions in data, or the interpretation of data, are not the responsibility of Durham Geo Slope Indicator (DGSi). The information herein is subject to change without notification.

This document contains information that is proprietary to DGSi and is subject to return upon request. It is transmitted for the sole purpose of aiding the transaction of business between DGSi and the recipient. All information, data, designs, and drawings contained herein are proprietary to and the property of DGSi, and may not be reproduced or copied in any form, by photocopy or any other means, including disclosure to outside parties, directly or indirectly, without permission in writing from DGSi.

SLOPE INDICATOR

12123 Harbour Reach Drive
Mukilteo, Washington, USA, 98275
Tel: 425-493-6200 Fax: 425-493-6250
E-mail: solutions@slope.com
Website: www.slopeindicator.com



Contents

Introduction	1
Installation	2
Manual Readings	5
Data Reduction	6
Connecting to Data Loggers	9

Introduction

Tiltmeter Applications

The MEMS tiltmeter is a uniaxial or biaxial device housed in a compact, waterproof enclosure for monitoring changes in the inclination of a structure. Applications for the tiltmeter include:

- Monitoring the rotation of retaining walls, piers, and piles.
- Monitoring the behavior of structures under load.

Operation

The sensors measure inclination from vertical. As wall or structural movement occurs, the tiltmeter moves with it, changing the inclination of the sensors.

The MEMS sensor used in the tiltmeter measures tilt over a range of +/-10 degrees from vertical. The biaxial model has a second sensor mounted 90 degrees to the first. Each sensor has signal conditioning circuits for easy connection to data loggers or acquisition systems.

Once the tiltmeter is mounted to the structure, it is normally adjusted so that it reads close to zero (no tilt). The initial reading is used as a baseline. Changes in the inclination of the structure are found by comparing current readings to the initial.

Several mounting brackets are available to suit various applications. Brackets may also be fabricated by the installer.

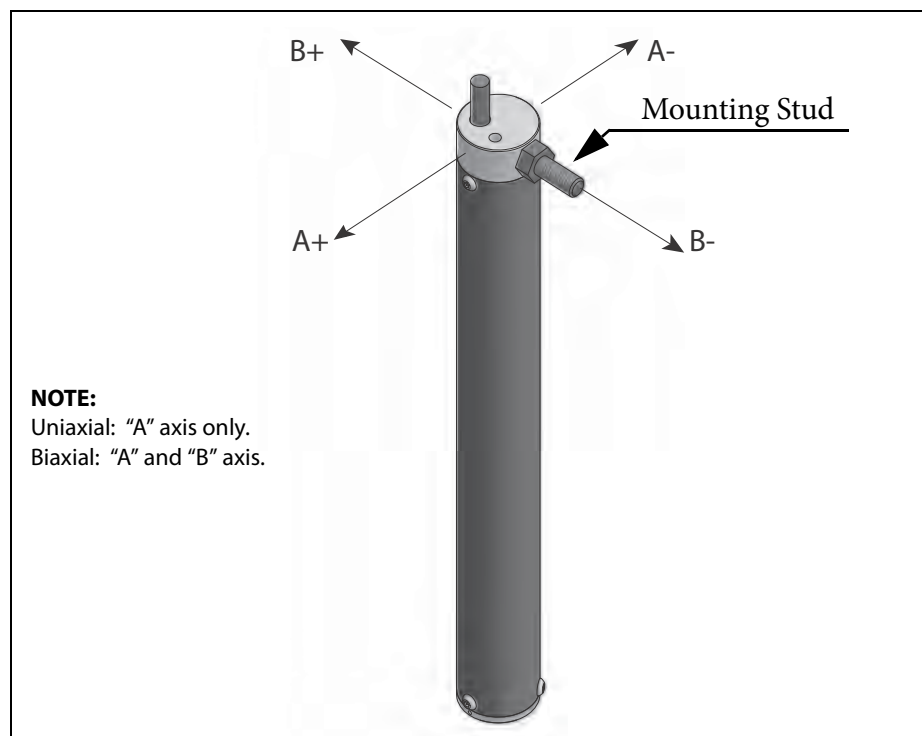

Installation

Installation Considerations

1. Protect from direct exposure to the sun.
2. Protect or shield cable to prevent damage.
3. Where possible, locate installation away from moving equipment.

Mounting the Tiltmeter

(Illustrations can be referenced on page 4).

Swivel Bracket Mount (Bolted)

1. Mark location for anchor. The swivel bracket requires one anchor.
2. Drill anchor hole in structure deep enough to embed about 50 mm of anchor. Remove debris.
3. Mix epoxy grout as directed by manufacturer. Fill hole with grout, then insert anchor.
4. After epoxy sets, place the swivel bracket onto the anchor and loosely attach hardware.
5. Attach the tiltmeter to the swivel bracket and loosely attach hardware.
6. Check that the sides of the tiltmeter are vertical before tightening bracket to anchor and tiltmeter against bracket.

Swivel Bracket Mount (Welded)

1. Mark location on steel structural member for swivel mount.
2. Verify mount is vertical and weld to structure.
3. Attach the tiltmeter to the welded bracket and loosely attach hardware.
4. Check that the sides of the tiltmeter are vertical before tightening tiltmeter against bracket.

Installation, Cont.

Floor Mount (Bolted)

1. Mark locations for anchors. The floor bracket requires one or two anchors.
2. Drill anchor hole(s) in floor deep enough to embed about 50 mm of anchor. Remove debris.
3. Mix epoxy grout as directed by manufacturer. Fill hole with grout, then insert anchor(s).
4. After epoxy sets, place the floor bracket onto the anchor(s) and tighten.
5. Place vertical bracket against floor bracket and loosely attach hardware.
6. Attach tiltmeter to vertical bracket and loosely attach hardware.
7. Check that the sides of the tiltmeter are vertical before tightening vertical bracket to floor bracket and tiltmeter against vertical bracket.

Floor Mount (Grouted)

1. Mark location for vertical bracket.
2. If existing installation, drill hole in floor deep enough to embed approximately 150 mm of vertical bracket. Remove debris.
3. Mix grout as directed, filling hole and inserting vertical bracket. Confirm bracket is vertical and support until grout sets.
4. Attach tiltmeter to vertical bracket. Check that sides of tiltmeter are vertical before tightening tiltmeter against bracket.

Installation, Cont.

The tiltmeter can be mounted on various surfaces as shown below.

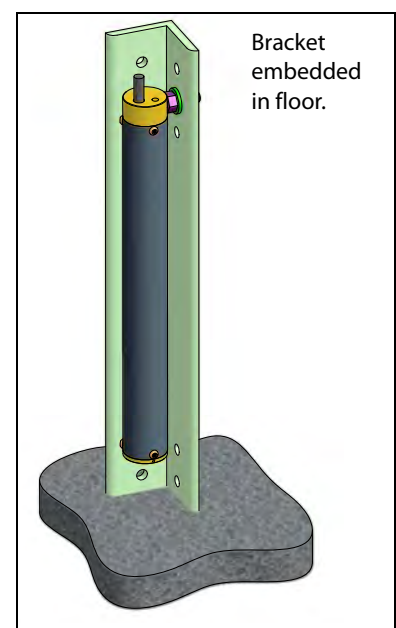
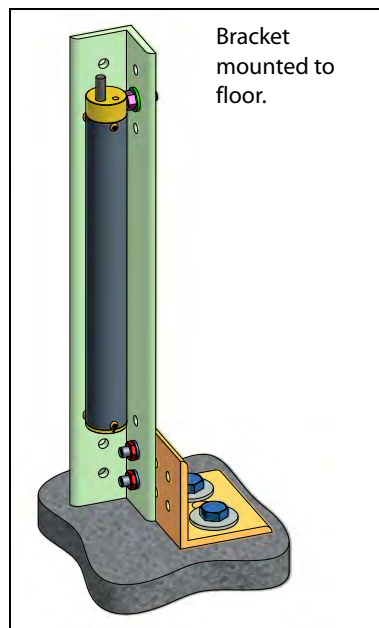
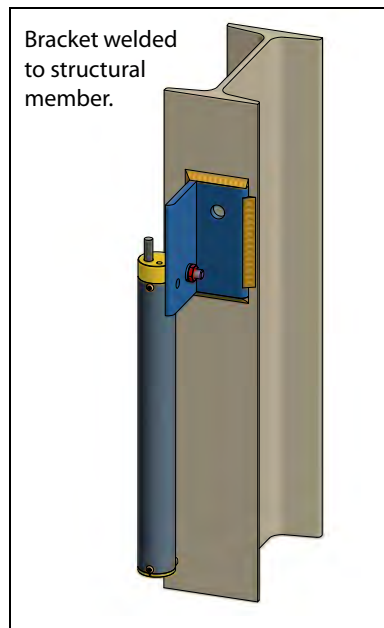
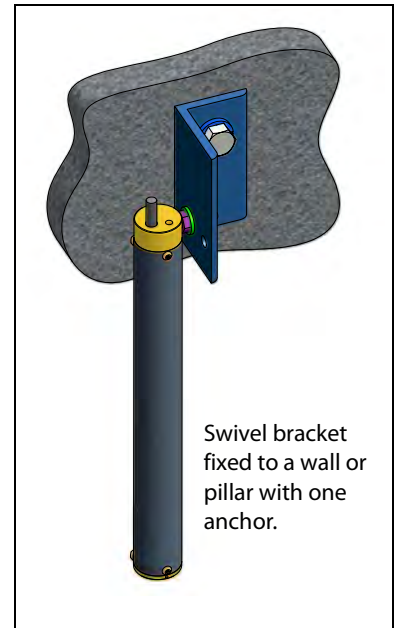
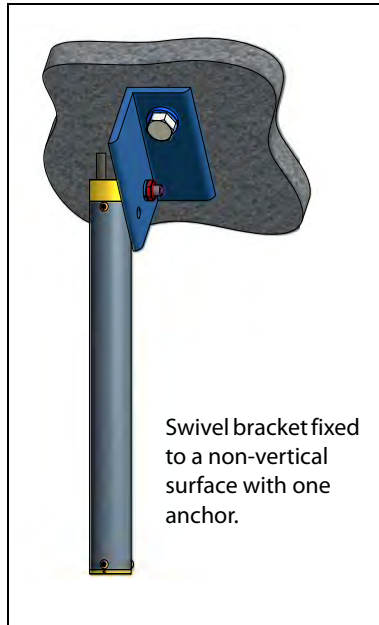
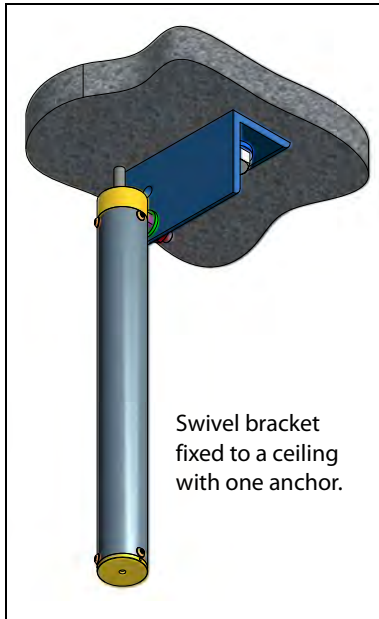

Manual Readings

Introduction Manual readings are useful for testing the system before the data acquisition system is set up.

EL/MEMS Data Recorder

1. Connect sensor to readout as shown in the table below.
2. Switch on. Choose uniaxial or biaxial sensor.
3. Tilt is displayed in volts. Temperature is displayed in degrees C.

Data Recorder Terminal	Signal Cable Wire
1 Tilt A	Orange
2 Tilt B	Blue
3 Temp	Red
4 Sig Common	Yellow
5 Sense	Violet
6 Power +	Green
7 Power -	Black
8 Shield	Drain Wire

Test Readings

1. When the sensor body is vertical, you should see a reading of about 0.0 Vdc in both axis.
2. The A-axis sensor measures tilt of the plane of the wall or structure. Tilting the sensor to 10 degrees should provide a reading of ± 2.2 to 2.3 Volts. (See drawing in the data reduction section).
3. The B-axis sensor (available with biaxial sensors only) is rotated 90 degrees from the A-axis sensor. Tilting the sensor to 10 degrees should provide a reading of ± 2.2 to 2.3 Volts.
4. At 25 degrees C, the thermistor reading should be about 1 Vdc.

Data Reduction

Introduction Data reduction is usually automated because it involves a large number of readings and a large number of calculations.

Here, we explain how to use the sensor calibration record and provide an example of converting a single reading in volts to tilt in mm per meter and tilt in degrees.

Calibration Record A calibration record is provided with each sensor. Use sensor serial numbers to match sensors with their calibrations. Calibrations are unique for each sensor.

The sensor calibration record provides two sets of factors. One set lists factors to convert readings in volts to tilt in mm per meter and also includes factors to calculate temperature corrections.

The other set lists factors to convert readings in volts to tilt in degrees and also includes factors to calculate temperature corrections.

Factors for A-axis sensors have a `_A` suffix. Factors for B-axis sensors have a `_B` suffix.

The bottom section of the calibration record shows how the factors are applied.

Converting Volts to Tilt To convert a reading in volts to mm/m or degrees of tilt, use the following formula:

$$\text{Tilt} = C3 \times \text{Volts}^3 + C2 \times \text{Volts}^2 + C1 \times \text{Volts} + C0$$

Where:

Tilt is a value in mm/m or degrees, depending on the factors used.

C3...C0 are factors for A-axis or B-axis.

Volts is the sensor reading in volts.

Correcting for Temperature The formula below shows how to adjust the tilt value for temperature:
Temp-Corrected Tilt = Tilt - (T1 × TdegC + T0)

Where:

Tilt is the value calculated above.

T1 and T0 are temperature factors for mm/m or degrees.

TdegC is the temperature in degrees C at the time of reading.

Example: Sensor 14295 gives an A-axis reading of 2.3V at 18C. The calibration factors are: C3_A = -1.2508E-2, C2_A = -3.6652E-2, C1_A = 7.2839E1, and C0_A = -3.9469. Use these factors in the formula from the previous page:

$$\text{Tilt} = \mathbf{C3 \times Volts^3 + C2 \times Volts^2 + C1 \times Volts + C0}$$

$$\text{Tilt}_{\text{mm/m}} = -1.2508\text{E-}2 \times 2.3^3 + -3.6652\text{E-}2 \times 2.3^2 + 7.2839\text{E}1 \times 2.3 + -3.9469$$

$$\text{Tilt}_{\text{mm/m}} = 163.24$$

The same sensor has temperature factors T0_A = -3.3162E-1 and T1_A = 2.4139E-2. Use these factors to adjust for temperature.

$$\text{Temp-Corrected Tilt} = \text{Tilt} - (\mathbf{T1 \times TdegC + T0})$$

$$\text{Temp-Corrected Tilt}_{\text{mm/m}} = 163.24 - (-3.3162\text{E-}1 \times 18 + 2.4139\text{E-}2)$$

$$\text{Temp-Corrected Tilt}_{\text{mm/m}} = 162.65$$

Example: Sensor 14295 gives a reading of 2.3V at 18C. The calibration factors are: C3_A_deg = -3.0241E-3, C2_A_deg = -2.7405E-3, C1_A_deg = 4.1733E0, and C0_A_deg = -2.2612E-1. Use these factors in the formula from the previous page:

$$\text{Tilt} = \mathbf{C3 \times Volts^3 + C2 \times Volts^2 + C1 \times Volts + C0}$$

$$\text{Tilt}_{\text{deg}} = -3.0241\text{E-}3 \times 2.3^3 + -2.7405\text{E-}3 \times 2.3^2 + 4.1733\text{E}0 \times 2.3 + -2.2612\text{E-}1$$

$$\text{Tilt}_{\text{deg}} = 9.3635$$

The same sensor has temperature factors T0_A_deg = -1.9109E-2 and T1_A_deg = 1.3911E-3. Use these factors to adjust for temperature.

$$\text{Temp-Corrected Tilt} = \text{Tilt} - (\mathbf{T1 \times TdegC + T0})$$

$$\text{Temp-Corrected Tilt}_{\text{deg}} = 9.2972 - (-1.9109\text{E-}2 \times 18 + 1.3911\text{E-}3)$$

$$\text{Temp-Corrected Tilt}_{\text{deg}} = 9.3611$$

Calculating Deviation

To calculate deviation over the gauge length of the sensor, use either formula below:

$$\text{Deviation}_{\text{mm}} = \text{Tilt}_{\text{mm/m}} \times \text{gauge_length}_{\text{m}}$$

or

$$\text{Deviation}_{\text{mm}} = \sin(\text{Tilt}_{\text{deg}}) \times \text{gauge_length}_{\text{mm}}$$

Example: Sensor 14295 has a gauge length of 2 meters. The examples below use the temperature corrected tilt values.

$$\text{Deviation}_{\text{mm}} = 162.65_{\text{mm/m}} \times 2 \text{ m}$$

$$\text{Deviation}_{\text{mm}} = 325.30$$

$$\text{Deviation}_{\text{mm}} = \sin(9.3611) \times 2000 \text{ mm}$$

$$\text{Deviation}_{\text{mm}} = 325.31$$

Calculating Displacement

Displacement (movement) is the change in deviation:

$$\text{Displacement} = \text{Deviation}_{\text{current}} - \text{Deviation}_{\text{initial}}$$

Direction of Tilt & Displacement

Uniaxial sensors respond to tilt in the plane perpendicular to the mounting stud of the sensor. This plane is called the A axis. A-axis readings may be positive or negative. In the drawing below, the sensor is viewed from the top.

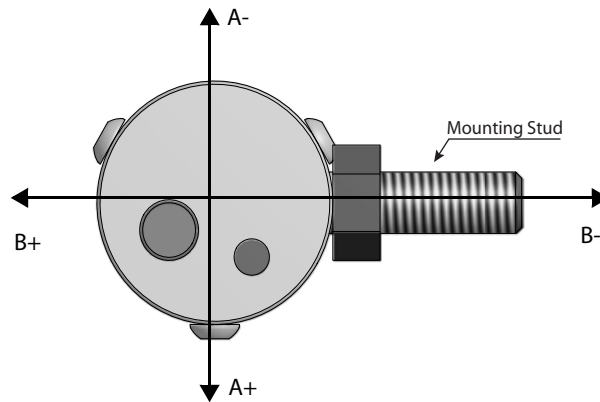

Biaxial sensors respond to tilt in the plane perpendicular to the mounting stud (A-axis) and the plane rotated in-line to the mounting stud (B-axis). Positive A-axis readings show tilt in the direction counter-clockwise of the mounting stud. Positive B-axis readings show tilt in the direction rotated 90 degrees clockwise. Displacement directions follow the same convention. Connection to Data Loggers

CR10X or CR1000

These instructions provide information needed for reading uniaxial and biaxial IPIs with the Campbell Scientific CR1000 datalogger system.

Sample Program: A sample CR1000 monitoring program is available at the Slope Indicator website. Go to www.slopeindicator.com. Then navigate to Support -> TechNotes -> DataLoggers, and look for sample programs.

Wiring Diagrams: The wiring diagrams on the following pages show how to connect uniaxial and biaxial IPIs to the Campbell Scientific CR1000 datalogger system.

Wiring Diagram 1 Uniaxial sensor connected directly to CR1000

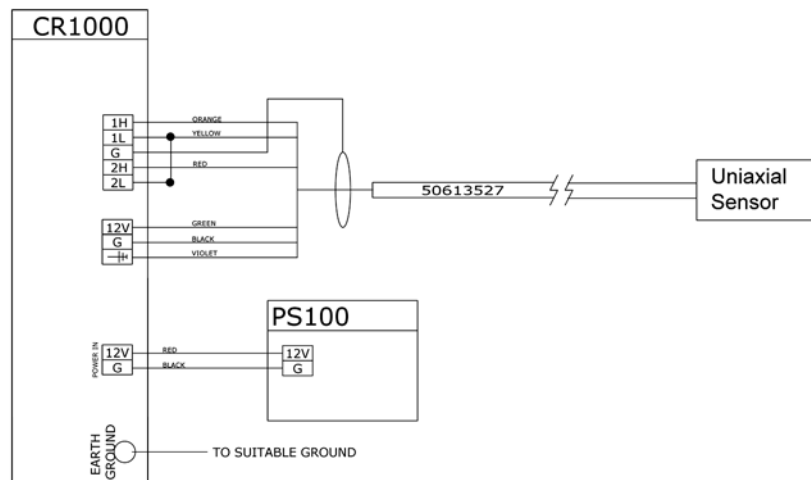

Wiring Diagram 2 Biaxial sensor connected directly to CR1000

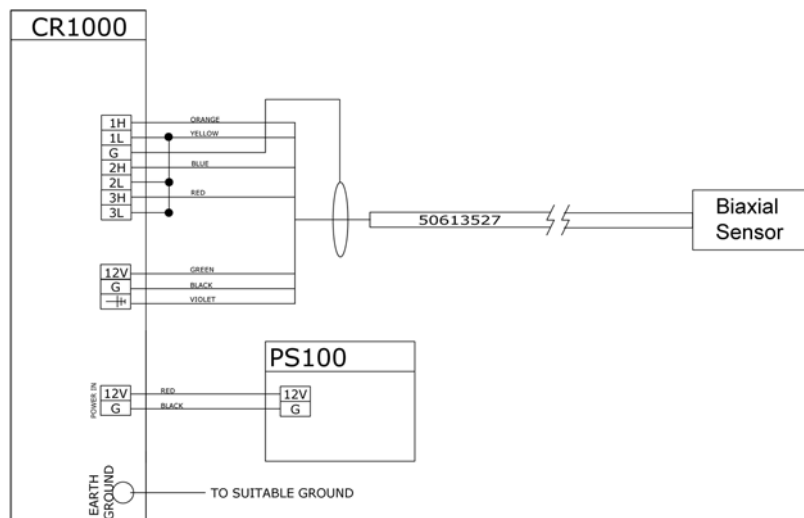

Wiring Diagram 3 Uniaxial sensor connected to AM16/32 multiplexer

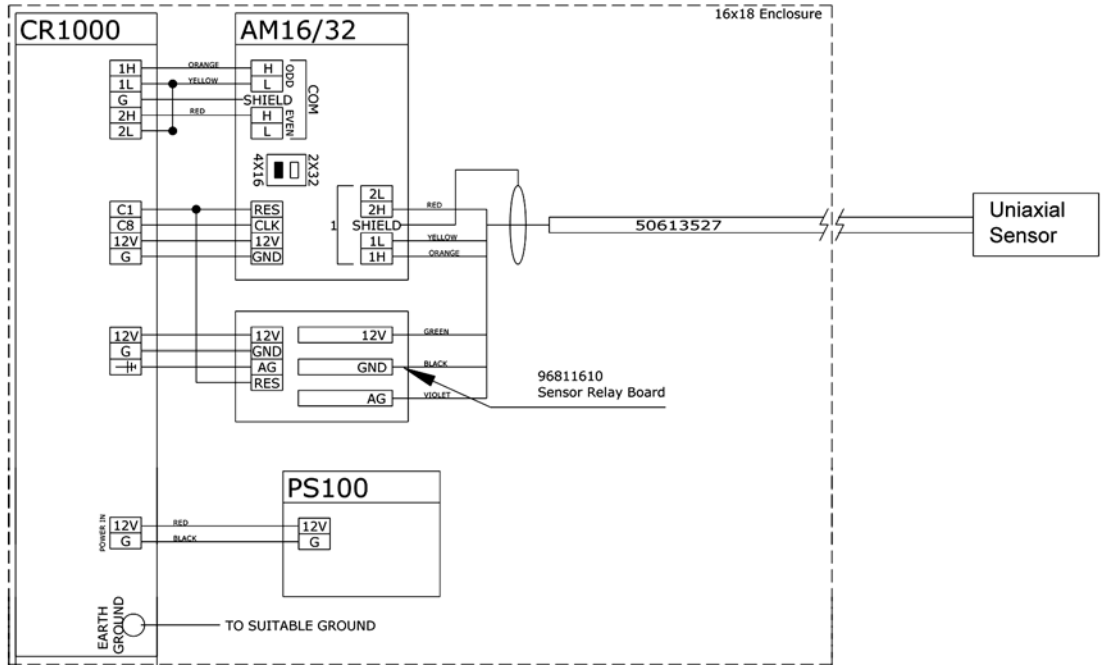

Wiring Diagram 4 Biaxial sensor connected to AM16/32 multiplexer

