

# **EL MonoPod Tiltmeter**

**56803199**

Copyright ©2003 Slope Indicator Company. All Rights Reserved.

This equipment should be installed, maintained, and operated by technically qualified personnel. Any errors or omissions in data, or the interpretation of data, are not the responsibility of Slope Indicator Company. The information herein is subject to change without notification.

This document contains information that is proprietary to Slope Indicator company and is subject to return upon request. It is transmitted for the sole purpose of aiding the transaction of business between Slope Indicator Company and the recipient. All information, data, designs, and drawings contained herein are proprietary to and the property of Slope Indicator Company, and may not be reproduced or copied in any form, by photocopy or any other means, including disclosure to outside parties, directly or indirectly, without permission in writing from Slope Indicator Company.

## ***SLOPE INDICATOR***

12123 Harbour Reach Drive  
Mukilteo, Washington, USA, 98275  
Tel: 425-493-6200 Fax: 425-493-6250  
E-mail: [solutions@slope.com](mailto:solutions@slope.com)  
Website: [www.slopeindicator.com](http://www.slopeindicator.com)

---

# Contents

Introduction.....	1
Installation .....	1
Manual Readings .....	2
Data Logging.....	4
Data Reduction.....	7

---

# EL MonoPod Tiltmeter

## Introduction

The EL Monopod Tiltmeter is designed to monitor changes in the inclination of a structure. It features a unique, single-point mount for easy installation anywhere.

The Monopod Tiltmeter is a uniaxial or biaxial electrolytic tiltmeter housed in a compact, waterproof enclosure. When the tiltmeter is read manually, changes in inclination are found by comparing the current reading to the initial reading.



The tiltmeter may also be connected to a data logger, which can obtain frequent readings, perform calculations, and trigger alarms if tilt or the rate of change exceeds preset limits

## Installation

1. Determine best drill size.
2. Tape smooth end of anchor to keep clean.
3. Drill hole into structure, then blow out debris.
4. Partially fill hole with grout.
5. Insert anchor. Allow grout to set.
6. Remove tape from anchor and slide tiltmeter onto anchor.
7. Use built in bubble level to zero the sensor.
8. Tighten bolt on swivel clamp.

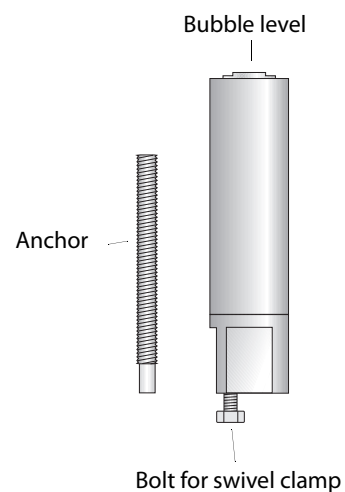

---

# Manual Readings

## EL Data Recorder

1. Connect sensor to readout as shown in the table below.
2. Switch on. Choose uniaxial sensor. Tilt is displayed in volts. Temperature is displayed in degrees C.

Data Recorder Terminal	Signal Cable Wire
1 Tilt A	Orange
2 Tilt B	Blue
3 Temp	Red
4 Sig Common	Yellow
5 Sense	Violet
6 Power +	Green
7 Power -	Black
8 Shield	Drain Wire

## DataMate MP

DataMate MP must have firmware version 05/01/02AA or later. See [www.slopeindicator.com-support-technotes-datamate mp](http://www.slopeindicator.com-support-technotes-datamate%20mp) for more information.

1. Connect sensor as shown in table below
2. Switch on. Choose Manual mode. Choose EL SC RO. A and B tilts are displayed in volts, temperature in degrees C.

Bare Wire Adapter	7-Wire Cable	Function
1	Orange	Tilt A
2	Yellow	Signal Common
3	Blue	Tilt B
4	Yellow	Signal Common
5	Red	Temp
6	Black	Power -
	Violet	Sense (analog gnd)
7	Yellow	Signal Common
8	Green	Power +
9		
10	Shield	

Use a jumper wire to connect terminals 2 and 7 of the bare-wire adapter. Black and violet wires are both connected to terminal 6.

## Voltmeter

You must have a power source, such as a 9-volt battery to supply between 5.5 and 15 Vdc to the sensor.

1. Connect green wire to the + terminal of the power source. Connect the violet wire and black wire to the - terminal of the power source.
2. To read the A-axis sensor, connect the voltmeter to the orange wire (signal) and yellow wire (reference). To read the B-axis sensor, connect the voltmeter to the blue wire (signal) and yellow wire (reference).
3. To read the thermistor, connect the voltmeter to the red and yellow wires.

## Test Readings

1. When the sensor body is vertical, you should see a reading of about 0.0 Vdc for either axis of the tiltmeter. The thermistor should provide a reading of about 1 Vdc at 25 degrees C.

2. The A-axis sensor measures tilt in the plane perpendicular to the wall. Tilt the top of the sensor toward the wall. The reading should increase to about 2200 or 2300

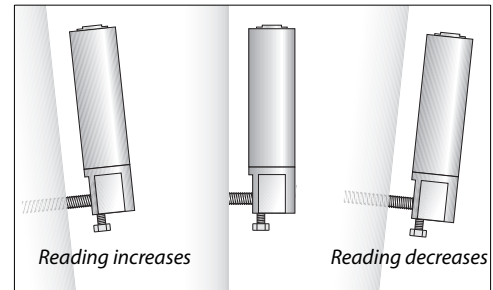

mV as the tilt nears 10 degrees. Tilt the top of the sensor away from the wall. The reading should decrease to about -2200 or -2300 mV as the tilt nears 10 degrees

3. The B-axis is oriented parallel to the wall. Tilt the top of the sensor to the left. The reading should decrease to about -2200 or -2300 mV as the tilt nears 10 degrees. Tilt the top of the sensor to the right. The reading should increase to about 2200 or 2300 mV as the tilt nears 10 degrees. Note that only biaxial sensors have a B-axis.

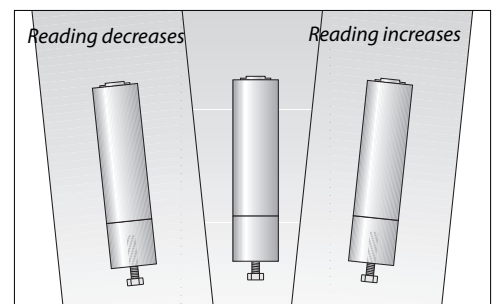

---

# DataLogging

**Requirements** The MonoPod tiltmeter has a built-in 2.5 volt signal conditioning board, so it can be read by most data loggers. The chart below shows a biaxial sensor. The uniaxial sensor has no B axis.

Wire Color	Function	Notes
Green	+ Power	5.5 to 15 Vdc, 6mA max per axis at 12 Vdc
Black	- Power (Ground)	Power and Analog Ground are tied together at Logger
Violet	Sense (Analog Ground)	
Yellow	Signal Common (Reference)	Yellow wire is jumpered to logger terminals to provide the - output for differential readings of A axis, B axis, and Thermistor
Orange	A Tilt	$\pm 2.5$ Vdc (differential).
Blue	B Tilt	$\pm 2.5$ Vdc (differential).
Red	Thermistor	160 to 1820 mV (differential)
Shield		

**Wiring Diagrams** Wiring diagrams on the following pages show how to connect uniaxial and biaxial sensors to the Campbell Scientific CR10X data logger system. The four diagrams show how to:

1. Connect uniaxial sensor directly to CR10.
2. Connect biaxial sensor directly to CR10.
3. Connect uniaxial sensor using AM416 multiplexer.
4. Connect biaxial sensor using AM416 multiplexer.

**Sample Program** A sample program is available at Slope Indicator's web site. Go to [www.slopeindicator.com](http://www.slopeindicator.com) - support - tech notes. Look at the data logger technotes. You'll see a link for sample programs.

Wiring Diagram 1 Connecting a uniaxial sensor directly to the CR10X

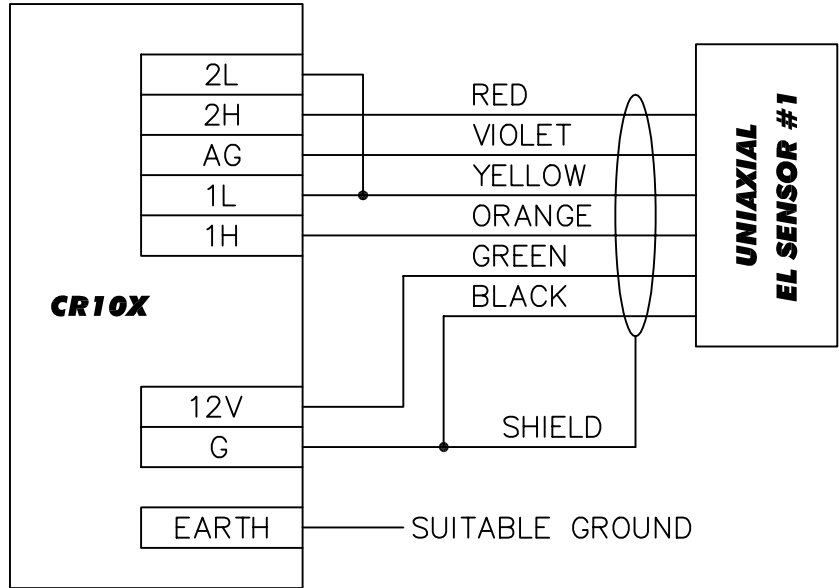

Wiring Diagram 2 Connecting a biaxial sensor directly to CR10X

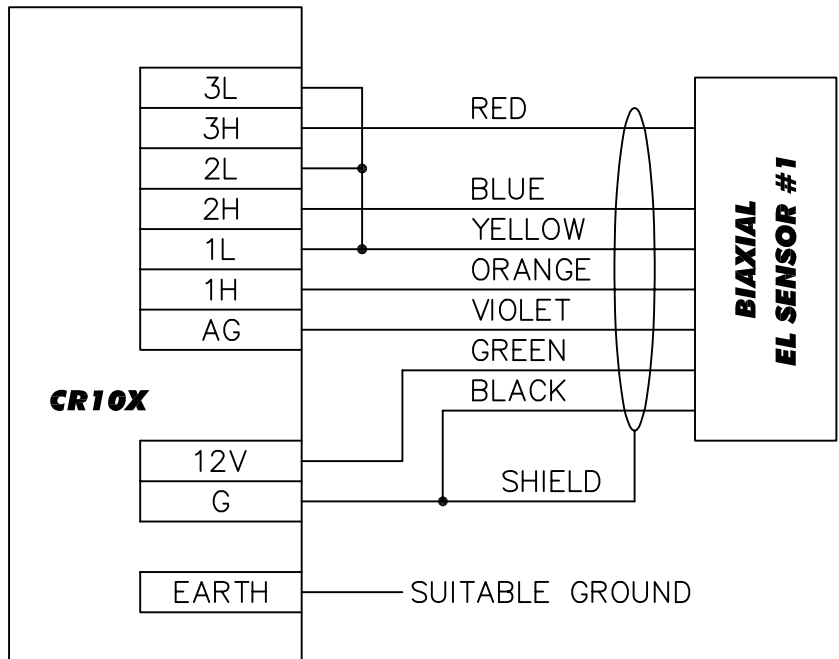

Wiring Diagram 3 Connecting uniaxial sensors to an AM416 multiplexer

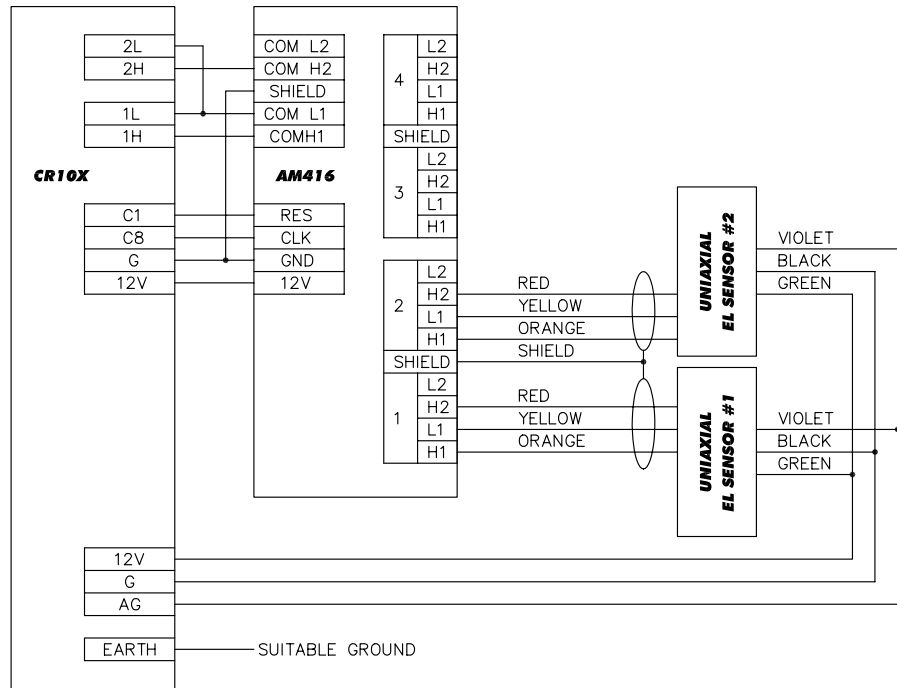

Wiring Diagram 4 Connecting biaxial sensors to an AM416 multiplexer

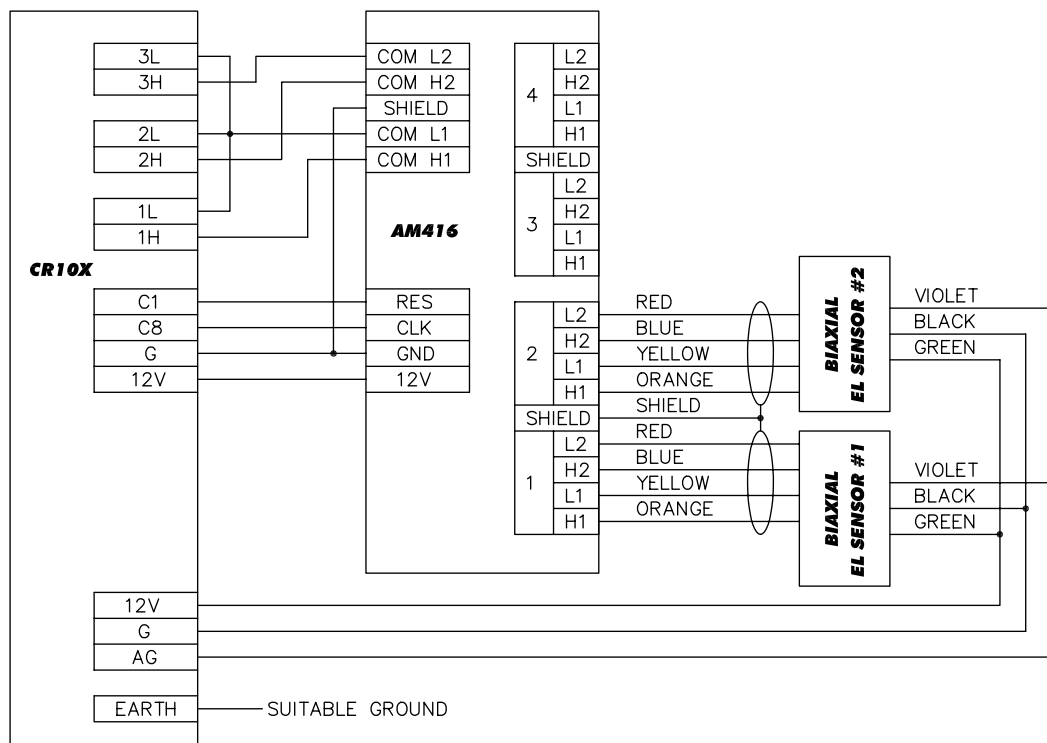

---

# Data Reduction

**Introduction** Data reduction is usually automated because it involves a large number of readings and a large number of calculations.

Here, we explain how to use the sensor calibration record and provide an example of converting a single reading from voltage to mm of deviation.

Once you have deviations, you can calculate displacements (movements) by subtracting the initial deviation from the current deviation.

**Calibration Record** A calibration record is provided with each sensor. Note that calibrations are unique for each sensor, so use sensor serial numbers to match sensors with their calibrations.

The sensor calibration record lists three sets of factors for each axis of the sensor and one factor for the temperature sensor. The table at right shows factors for sensor serial number 10001. Your sensors will have different factors.

**C0 to C5:** Use these factors to convert a reading in volts to mm per meter of gauge length.

**S0 to S2:** Use these factors to adjust the mm/m value above for temperature-related changes in sensor sensitivity.

**F0 to F2:** Use these factors to adjust the mm/meter value for temperature-related changes in the offset of the sensor.

**Toffset:** Use this factor in the equation to convert a thermistor reading in volts to degrees C.

**Tnom:** Tnom is normally 12 degrees C. However, the value shown on the sensor calibration record may be higher or lower if your sensors were calibrated over a custom range of temperatures.

C0	-7.0311
C1	73.878
C2	-0.22265
C3	-0.33079
C4	0.019426
C5	0.020221
S0	1
S1	0.00059828
S2	0.0000068117
F0	00012125
F1	0.016273
F2	0.00096919
Toffset	0.19
Tnom	12

---

## Applying Calibration Factors

Suppose you obtain a reading of 570 millivolts (0.57V) from sensor 10001, which has a gauge length of 2 meters. How do you convert the voltage reading to mm of deviation?

### Converting sensor reading to mm per meter

Apply the C factors to the voltage reading as shown below. EL represents a reading in volts. C5 through C0 are factors that appear on the sensor calibration record. The result of the calculation is a value in mm per meter.

$$\text{mm/meter} = C5 \cdot EL^5 + C4 \cdot EL^4 + C3 \cdot EL^3 + C2 \cdot EL^2 + C1 \cdot EL + C0$$

	C Factor	EL Reading	Value
C0	-7.0311		-70311
C1	73.878	0.57	42.11046
C2	-0.22265	$0.57^2$	-0.07234
C3	-0.33079	$0.57^3$	-0.06126
C4	0.19426	$0.57^4$	0.002051
C5	0.020221	$0.57^5$	0.001217
mm per meter deviation =			34.94903

### Calculating deviation in mm

To calculate deviation for a particular gauge, multiply the mm/meter value by the gauge length of the sensor.

$$\text{deviation in mm} = \text{mm/meter value} \cdot \text{gauge length of sensor}$$

In this example, the gauge length is 2 meters, so the deviation would be about 70 mm.

## Temperature Readings

The CR10 delivers thermistor readings in volts. The equation below shows how to convert the volt reading to degrees C. The factors in the equation are optimized for temperatures between -15 and 85 degrees C. ET is the volt reading. Toffset is taken from the sensor calibration sheet.

$$\text{DegC} = (9.3219 \times \text{ET}^5) + (-54.3038 \times \text{ET}^4) + (131.165 \times \text{ET}^3) + (-161.2568 \times \text{ET}^2) + (137.7711 \times \text{ET}) + (-37.7705) - \text{Toffset}$$

## Correcting for Temperature

Changes in temperature affect both the sensitivity and the offset of the sensor. In the instructions below, the sensitivity temperature correction is called SENSTC. The offset temperature correction is called OFFSTC.

1. Find the change in temperature from Tnom, which is a value on the sensor calibration sheet.

$$\text{DeltaT} = \text{DegC} - \text{Tnom}$$

For our example, DegC is 19.3 and Tnom is 12 degrees C, so DeltaT, the change in temperature, is 7.3 degrees C.

2. Calculate the sensitivity correction:

$$\text{SENSTC} = \text{S2} \cdot \text{DeltaT}^2 + \text{S1} \cdot \text{DeltaT} + \text{S0}$$

	S Factor	DeltaT	Value
S0	1		1
S1	0.00059828	7.3	0.004367
S2	0.0000068117	7.3 <sup>2</sup>	0.000363
SENSTC =			1.00473

3. Calculate the offset correction:

$$\text{OFFSTC} = \text{F2} \cdot \text{DeltaT}^2 + \text{F1} \cdot \text{DeltaT} + \text{F0}$$

	F Factor	DeltaT	Value
F0	0.00012125		.000121
F1	0.016273	7.3	0.118793
F2	0.00096919	7.3 <sup>2</sup>	0.051648
OFFSTC =			0.170562

4. Apply the corrections:

$$\begin{aligned} \text{corrected value} &= (\text{mm/meter value} \cdot \text{SENSTC}) + \text{OFFSTC} \\ &= (34.94903 \cdot 1.00473) + 0.170562 \\ &= 35.28491 \end{aligned}$$