

Multiplexed EL In-Place Inclinometer

56804599

Copyright ©2006 Durham Geo Slope Indicator. All Rights Reserved.

This equipment should be installed, maintained, and operated by technically qualified personnel. Any errors or omissions in data, or the interpretation of data, are not the responsibility of Slope Indicator Company. The information herein is subject to change without notification.

This document contains information that is proprietary to Slope Indicator company and is subject to return upon request. It is transmitted for the sole purpose of aiding the transaction of business between Slope Indicator Company and the recipient. All information, data, designs, and drawings contained herein are proprietary to and the property of Slope Indicator Company, and may not be reproduced or copied in any form, by photocopy or any other means, including disclosure to outside parties, directly or indirectly, without permission in writing from Slope Indicator Company.

SLOPE INDICATOR

12123 Harbour Reach Drive
Mukilteo, Washington, USA, 98275
Tel: 425-493-6200 Fax: 425-493-6250
E-mail: solutions@slope.com
Website: www.slopeindicator.com

Contents

Introduction	1
Pre-Assembly	5
Vertical Installation	6
Horizontal Installation.....	11
Data Logging	14
Data Reduction	15
Removing Sensors	20

Introduction

In-Place Inclinometers

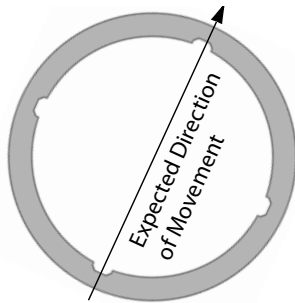

In vertical installations, one pair of casing grooves should be aligned with the expected direction of movement.

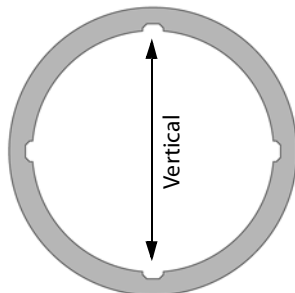

In horizontal installations, one pair of casing grooves must be aligned to vertical.

The in-place inclinometer system consists of inclinometer casing and a string of linked in-place inclinometer sensors.

The inclinometer casing provides access for subsurface measurements, controls the orientation of the sensors, and moves with the surrounding ground.

In vertical installations, the inclinometer casing is installed in a borehole that passes through a suspected zone of movement. One set of grooves is aligned in the expected direction of movement (downhill, for example).

In horizontal installations, inclinometer casing is typically installed in a trench. One set of grooves must be aligned to vertical, since the instrument is expected to monitor vertical movements (settlement or heave).

The string of linked sensors is positioned inside the casing to span the zone of movement. Vertical sensors measure inclination from vertical. Horizontal sensors measure inclination from horizontal.

When the ground moves, the casing moves with it, changing the inclination of the sensors inside the casing. Inclination measurements from the sensors are processed to provide displacement readings in mm of displacement for the gauge length of each sensor.

In most applications, sensors are connected to a data acquisition system and data processing is completed by a computer program.

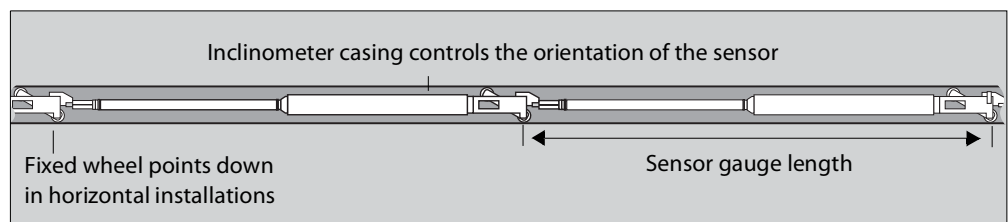
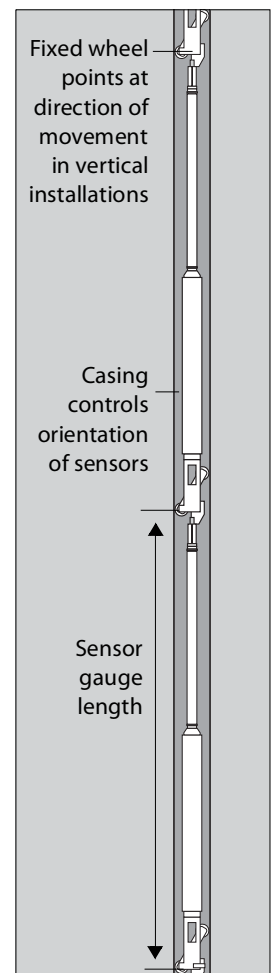

IPI Sensor Components

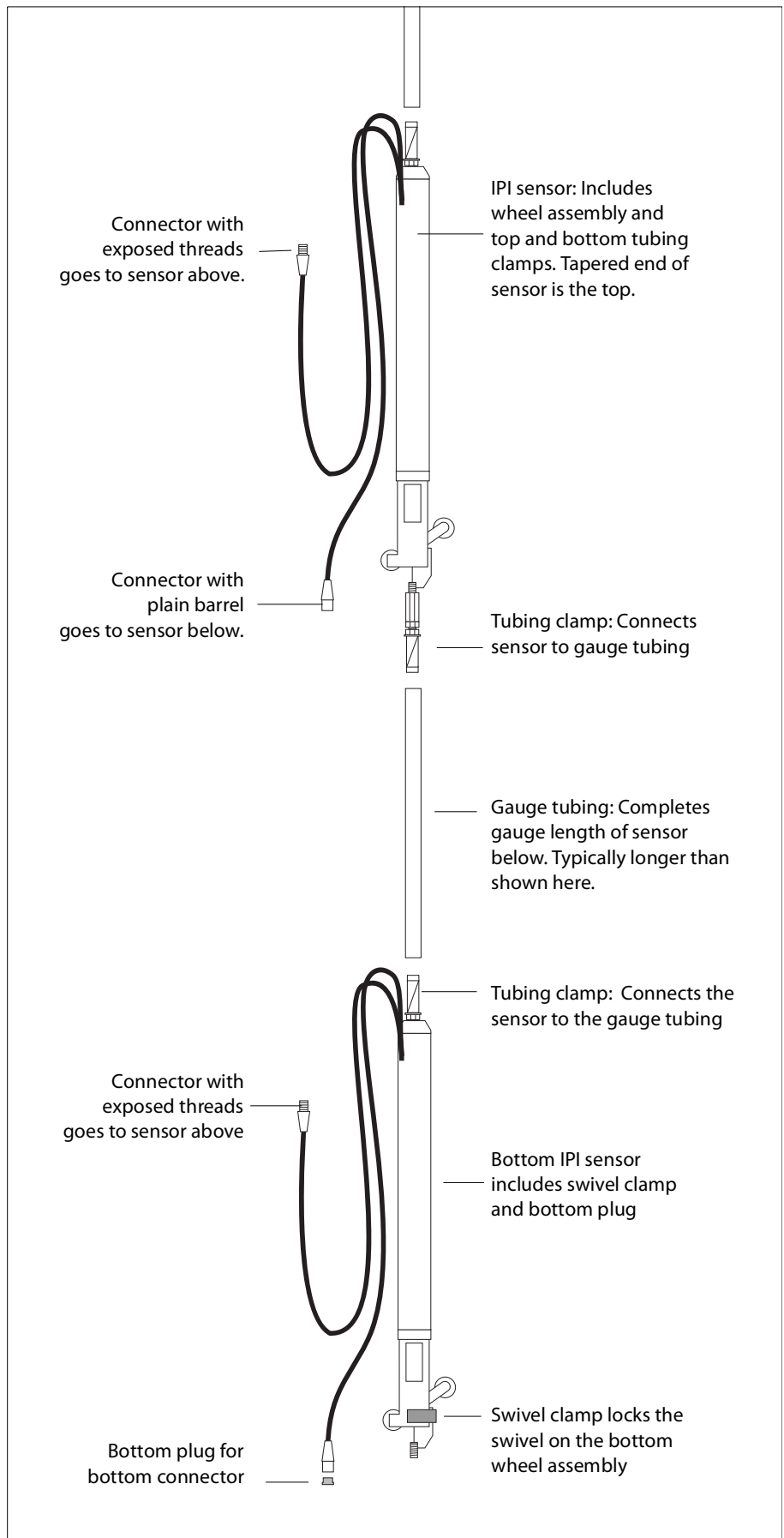

Other Components

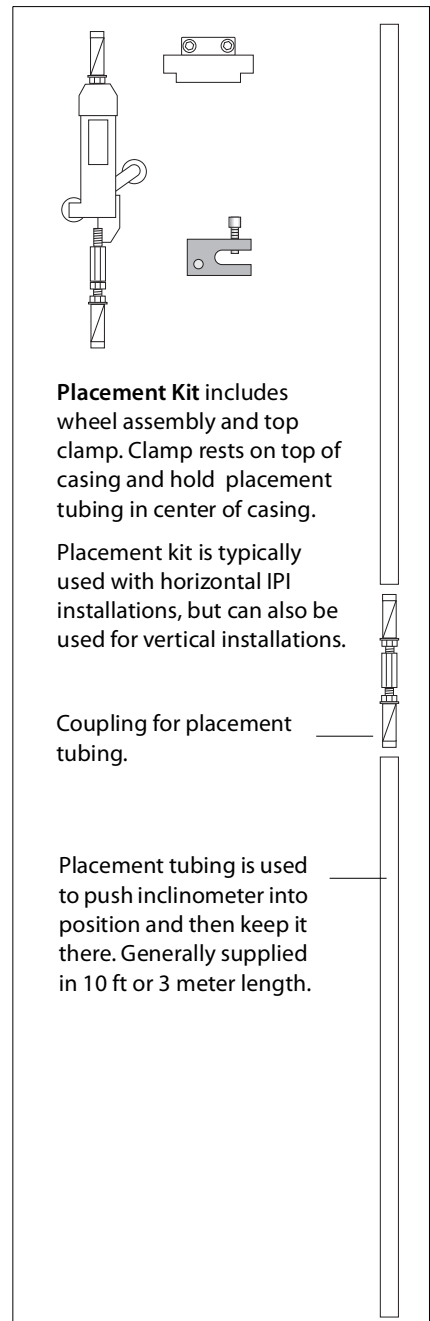
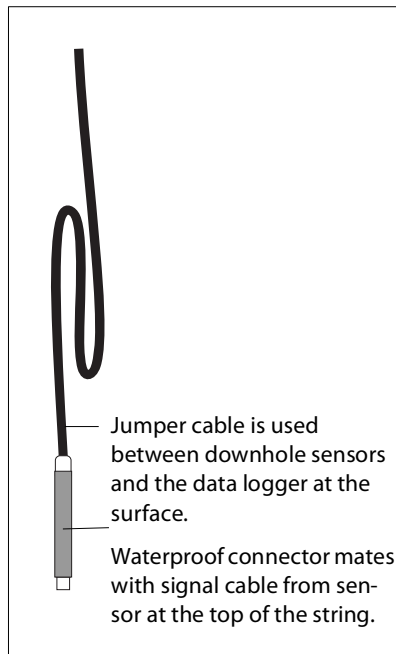
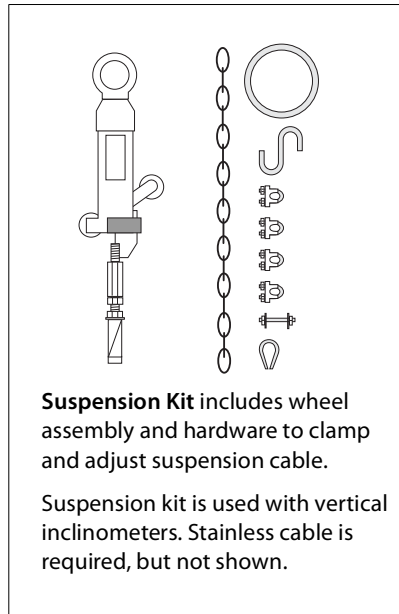

Gauge Tubing Gauge tubing is typically ordered with the sensors. If gauge tubing is not supplied, check project specifications for required gauge length, and then follow the instructions below:

1. Choose stainless tubing that can accept tubing clamps. The standard tubing clamps have a minimum OD of 15.6 mm (0.615 inch) and expand to a maximum OD of 17.4 mm (0.685 inch).
2. Measure and mark the gauge tubing for the proper length:
tubing length = total gauge length – 550 mm (21.625 inch).
For example, you would cut tubing lengths of 1450 mm for a total gauge length of 2 meters.
3. Cut and deburr the gauge tubing. Check that tubing clamps fit inside.

Suspension Cable Suspension cable, if used, is typically ordered with the system. The suspension kit contains hardware for 3/16 inch cable. The cable is 3/16 inch, 19 x 7, stainless steel aircraft cable.

Placement Tubing Placement tubing, if used, is typically ordered with the system. If placement tubing is required, but not supplied, follow the instructions below.

1. Choose stainless tubing that can accept tubing clamps and couplings. The standard tubing clamps have a minimum OD of 15.6 mm (0.615 inch) and expand to a maximum OD of 17.4 mm (0.685 inch).
2. Deburr the gauge tubing and check that tubing clamps fit inside.
3. Use the coupling shown on previous page to join lengths of placement tubing.
4. Use in-line wheel assembly if placement tubing must be articulated.

Safety Cable In vertical installations, you may find it useful to connect a safety cable to the bottom sensor to prevent accidental loss of the sensors.

Pre-Assembly

Identify Sensors

1. Sensors are shipped calibration records. Use the sensor serial number to verify that you have a calibration record for each sensor.
2. Identify the bottom sensor for each string. The bottom sensor has a swivel clamp and a plug for the bottom connector.
3. Plan the order of installation. Note the serial number and the intended position of each sensor.
4. Verify that the system is working by connecting the sensors to a data logger. See section on Data Logging for details.

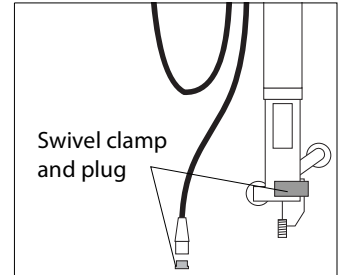

Attach Gauge Tubing to Each Sensor

Remove the tubing clamp from the top of each sensor. Insert the clamp into the gauge tubing. Tighten well. Then screw the gauge tubing into the sensor body. Body and tubing should form rigid unit.

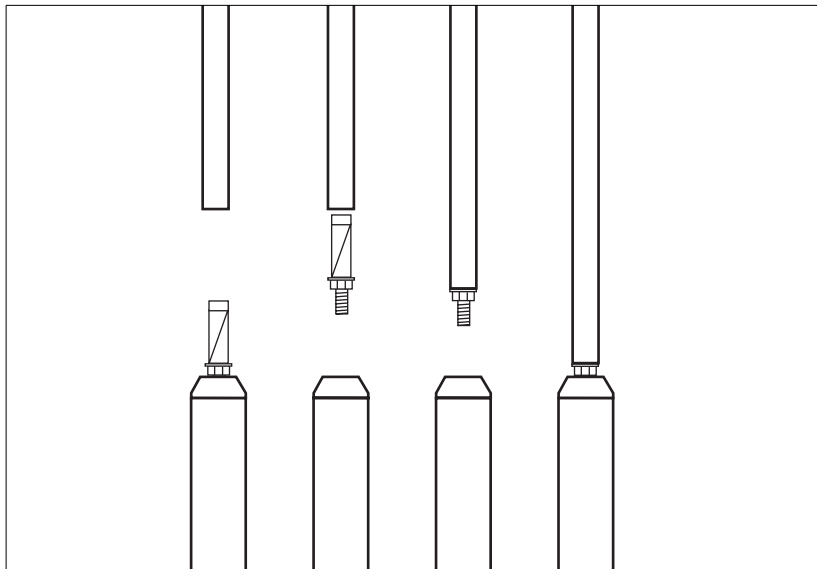

Vertical Installation

- Overview**
1. Lay out sensors in order of installation.
 2. Insert the first sensor in the preferred set of grooves. The fixed wheel should point toward the expected direction of movement.
 3. Lower the sensor into the casing. Keep the top of the gauge tube accessible.
 4. Connect the next sensor to the gauge tubing of the downhole sensor.
 5. Connect the signal cable from the downhole sensor.
 6. Lower the sensor into the casing. Repeat steps 4 and 5 until all of the sensors have been connected and installed.
 7. Prepare the suspension kit or the placement kit.
 8. Lower the sensors to their final location and terminate.

- Required Tools**
- Safety cable attached to bottom sensor to prevent loss of sensors down hole.
 - Vice grips (clamping pliers) for holding gauge tubing while connecting adjacent sensors.
 - Thin 17 mm wrench for tightening tubing clamps.
 - Tools for cable clamps or Allen wrench for securing top clamp.
 - Vinyl tape for securing cable to gauge tubing.

- Preparations**
1. Note serial number and position of each sensor.
 2. Lay out sensors in order of installation. Be sure to keep signal cable connectors clean.
 3. Attach gauge tubing to each sensor, as explained on previous page.

Install Bottom Sensor

1. Attach safety line to bottom sensor. Secure the safety line.
2. Insert the bottom (first) sensor in the preferred set of grooves. The fixed wheel should point to the expected direction of movement. Check that the wheel has a swivel clamp.
3. Lower the sensor into the casing. Tape signal cable to gauge tubing. Use vice grips to clamp top of gauge tubing. Now next sensor can be installed.

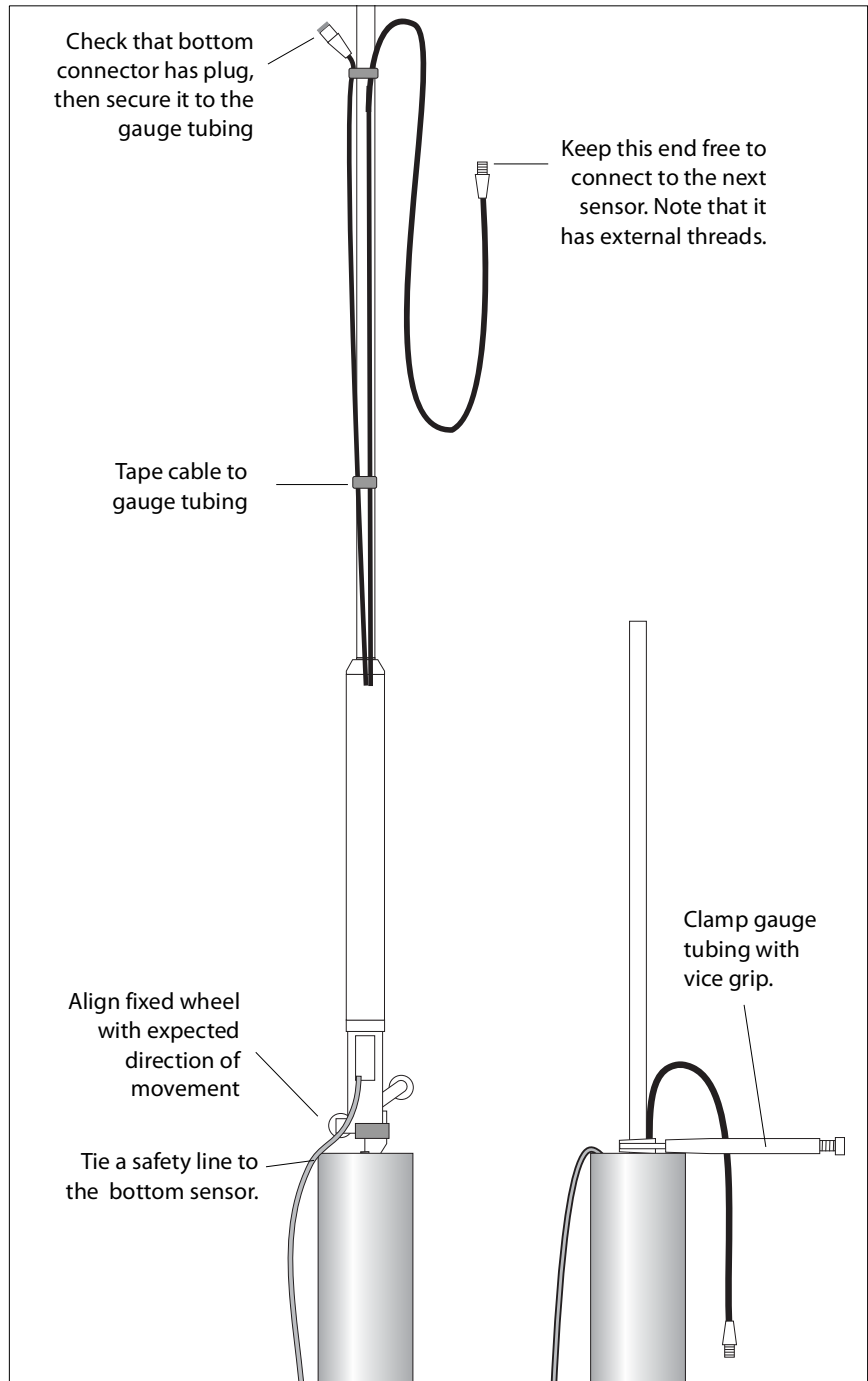

Install Additional Sensors

1. Connect signal cables. Make a loop of the excess cable and tape to gauge tubing.
2. Connect sensors. First, check that the fixed wheel is aligned with proper groove, then join sensors. Do not twist sensors when tightening nuts. Loop excess cable and tape to gauge tubing.
3. Continue adding sensors until the sensor string is complete.

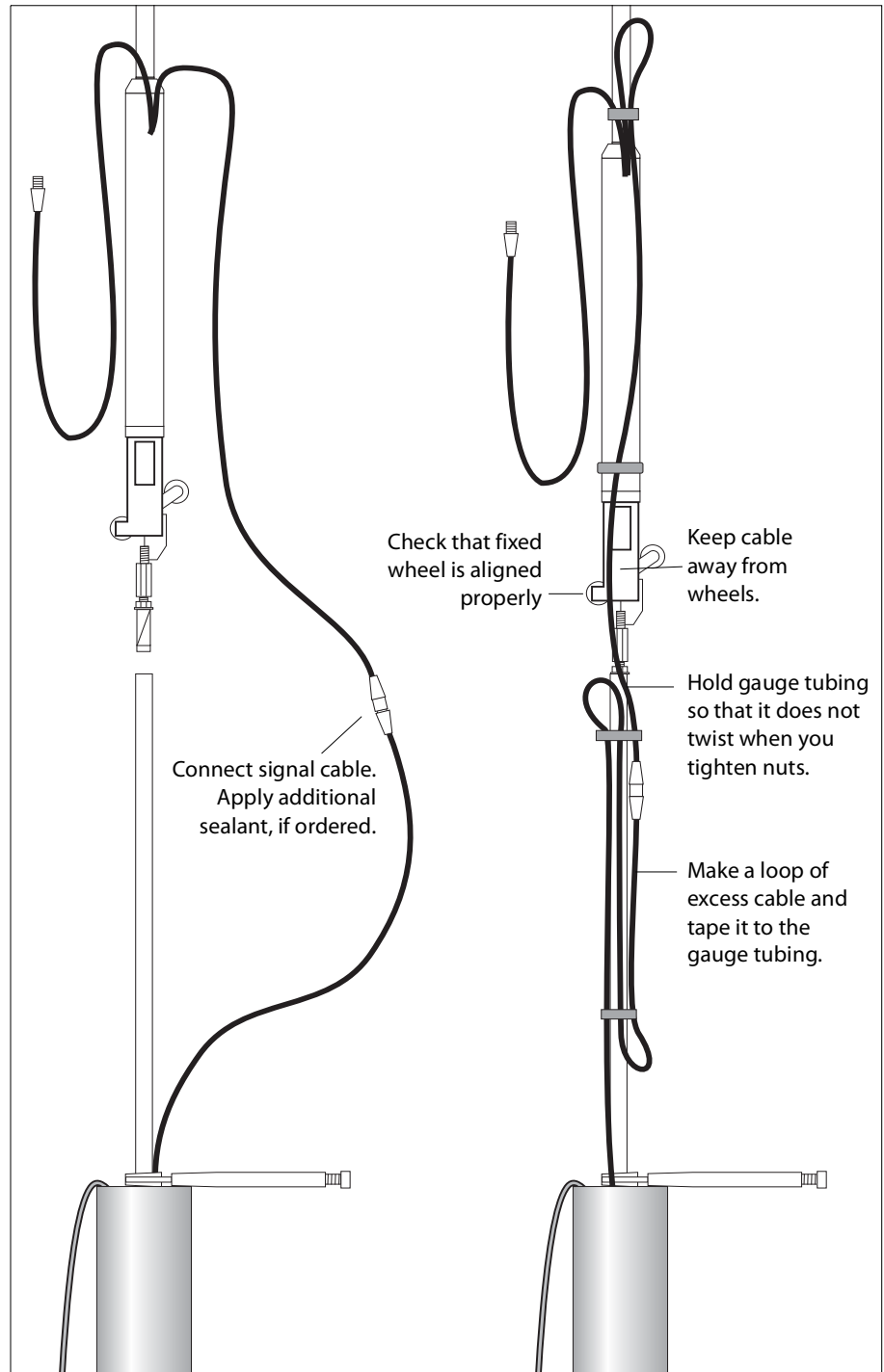

Install Jumper, and Top Wheel

1. Jumper cable runs from downhole sensors to data logger. Connect jumper cable to signal cable from top sensor.
2. Attach top wheel from suspension kit or placement kit.
 - Wheel supplied in suspension kit has an eyelet for suspension cable. Connect suspension cable as shown in drawing.
 - Wheel supplied in placement kit has tubing clamp. Attach placement tubing as shown in the drawing.

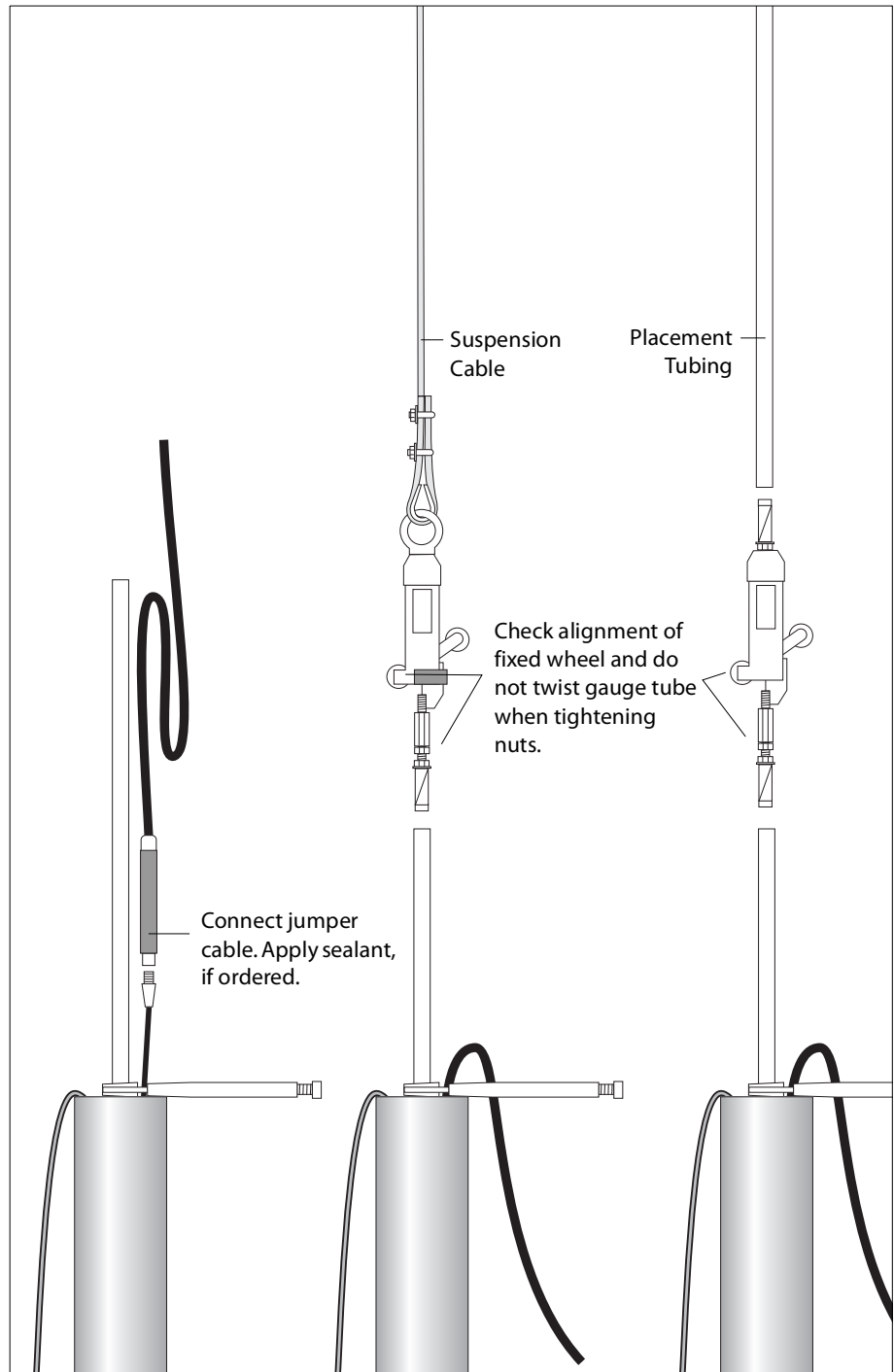

Terminate with Suspension Kit

The suspension kit is used with vertical installations. It consists of a top wheel assembly, shown on the previous page, cable thimbles, cable clamps, and a hook for the top of the casing.

1. Cut the suspension cable to the appropriate length.
2. Attach the cable to the top wheel assembly using the thimble and clamps.
3. Attach the other end of the cable to the chain, as shown in the drawing.
4. Use the chain is used to adjust the final depth of the sensors.

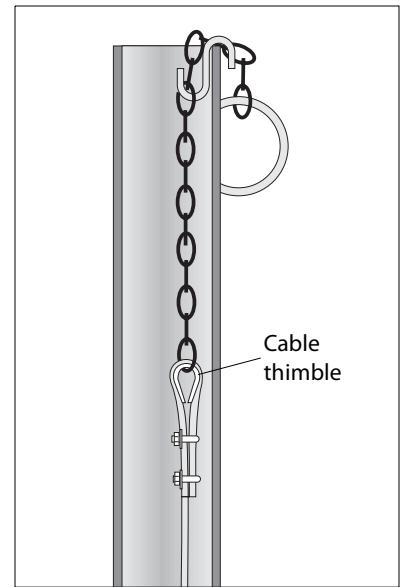

Terminate with Placement Kit

The placement kit is sometimes used with vertical installations. It consists of a top wheel assembly, shown on the previous page, and a “top” clamp for placement tube.

The top clamp holds either placement tubing - when the sensors are deeper in the casing - or the gauge tube of the nearest sensor.

The top clamp has a split collar. Loosen the screws, slide the collar over the placement tubing or gauge tubing, and then tighten the screws.

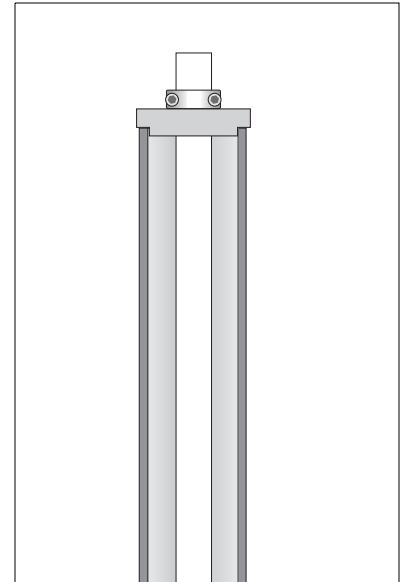

Horizontal Installation

- Overview**
1. Lay out sensors in order of installation.
 2. Align the first sensor with the vertical grooves of the casing. Insert the sensor with its fixed wheel pointing downwards.
 3. Push the sensor into the casing. Keep the top end of its gauge tubing accessible.
 4. Connect the next sensor to the gauge tubing of the downhole sensor. Then push it into the casing.
 5. Continue connecting sensors until the string is complete.
 6. Connect the final wheel assembly.
 7. Prepare the placement kit and placement tubing.
 8. Push push sensors to final location and terminate.

- Required Tools**
- Safety cable may be useful if sensors are to be retrieved or if casing actually slopes downwards.
 - Vice grips (clamping pliers) for holding gauge tubing while connecting adjacent sensors.
 - Thin 17 mm wrench for tightening tubing clamps.
 - Allen wrench for securing top clamp.
 - Vinyl tape for securing cable to gauge tubing.

- Preparations**
1. Attach gauge tubing to each sensor, as explained on previous page.
 2. Lay out sensors in order of installation. Note the serial number and position of each sensor.
 3. Keep cables coiled until sensor is installed.

Install the First Sensor

1. Check that the first sensor has a swivel clamp on its wheel assembly.
2. Tape signal cable to the gauge tubing.
3. Align the fixed wheel with the bottom groove and push the sensor into the casing.

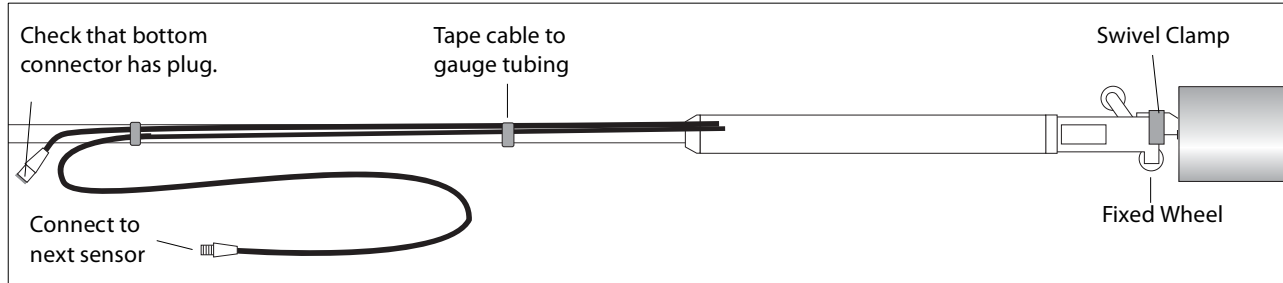

Install More Sensors

1. Align the fixed wheel with the bottom groove. Push the tubing clamp into the gauge tubing of the sensor that is already in the casing. Tighten tubing clamp. Do not twist the gauge tubing when you tighten.
2. Connect signal cable, applying additional sealant, if ordered. Make a loop of excess cable and tape to the gauge tubing. Keep cable as neat as possible and away from wheels. Ideally cable should not touch the casing.
3. Continue adding sensors until the sensor string is complete

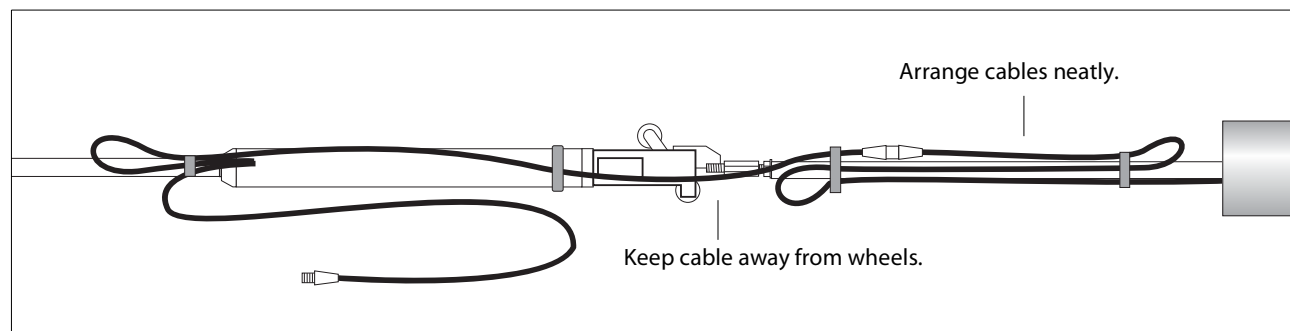
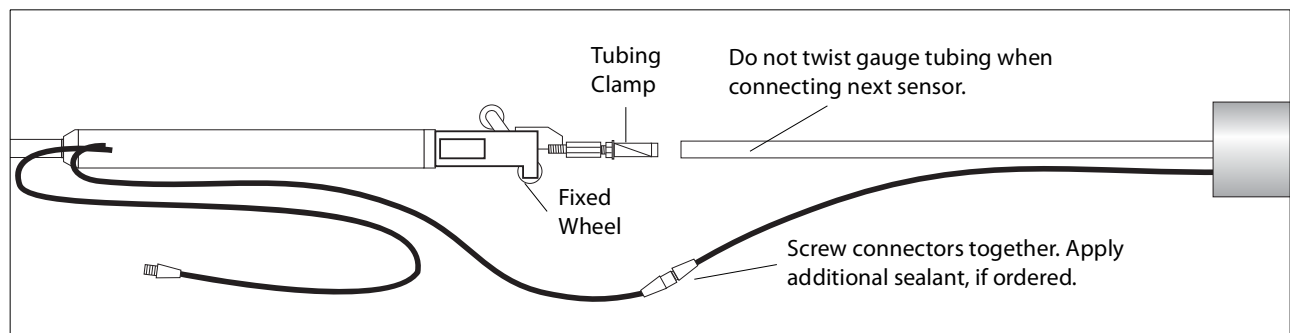

Terminating the Installation

The placement kit supplies most of the components used to terminate horizontal installations. The placement kit includes a top wheel assembly and a top clamp. A top clamp retainer is also available.

Connect Jumper

Jumper cable runs from sensors to data logger. Connect jumper cable to signal cable from top (nearest) sensor

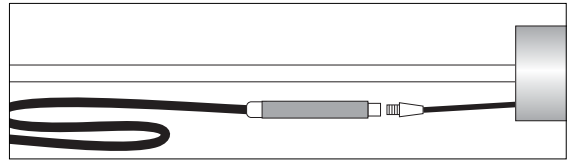

Install Top Wheel

The top wheel completes the gauge length of the nearest sensor. Align the fixed wheel with the bottom groove.

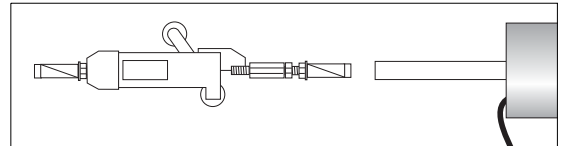

The top wheel is not required if the gauge length of the top sensor is terminated with the top clamp.

Install Placement Tubing

Placement tubing is used to position the sensors deeper into the casing. Placement tubing is normally longer than shown in the illustration. A coupling is used to join two placement tubes.

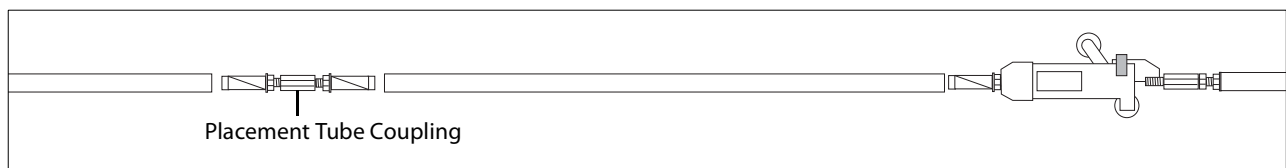

Install the Top Clamp

The top clamp holds placement tubing or the gauge tube of the nearest sensor.

1. The top clamp has a split collar. Loosen the screws, slide the collar over the placement tubing or gauge tubing, and then tighten the screw.

2. (Optional) Use the top clamp retainer to hold the top clamp to the casing.

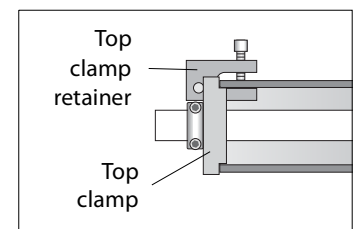

3. In horizontal installations, the sensors normally must be pushed into the casing. This puts the mechanical linkage of the sensors into compression. If possible, put the linkage into tension, but pushing the sensors deeper into the casing and then pulling them back into position.

DataLogging

Wiring Diagram for CR10X

The wiring diagram below shows how to connect signal cable to a CR10X data logger.

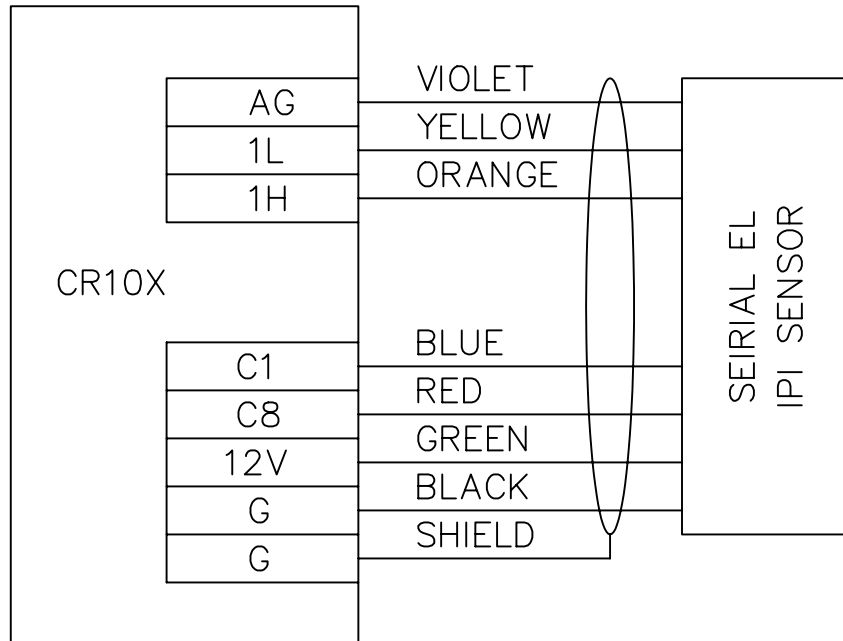

Sample Program

A sample monitoring program is available at Slope Indicator's website. Go to www.slopeindicator.com - support- tech notes. Look at notes for data loggers. You'll see a link for sample programs.

Data Reduction

Introduction Data reduction is usually automated because it involves a large number of readings and a large number of calculations.

Here, we explain how to use the sensor calibration record and provide an example of converting a single reading from voltage to mm of deviation and displacement.

Once you have deviations, you can calculate displacements (movements) by subtracting the initial deviation from the current deviation.

Calibration Record A calibration record is provided with each EL IPI sensor. Note that calibrations are unique for each sensor, so use sensor serial numbers to match sensors with their calibrations.

The sensor calibration record lists three sets of factors for each axis of the sensor and one factor for the temperature sensor. The table at right shows factors for sensor serial number 10001. Your sensors will have different factors.

C0 to C5: Use these factors to convert a reading in volts to mm per meter of gauge length.

S0 to S2: Use these factors if it is necessary to adjust the mm/m value above for temperature-related changes in sensor sensitivity.

F0 to F2: Use these factors if it is necessary to adjust the mm/meter value for temperature-related changes in the offset of the sensor.

Toffset: Use this factor in the equation to convert a thermistor reading in volts to degrees C.

Tnom: Tnom is normally 12 degrees C. However, the value shown on the sensor calibration record may be higher or lower if your sensors were calibrated over a custom range of temperatures.

C0	-7.0311
C1	73.878
C2	-0.22265
C3	-0.33079
C4	0.019426
C5	0.020221
S0	1
S1	0.00059828
S2	0.0000068117
F0	00012125
F1	0.016273
F2	0.00096919
Toffset	0.19
Tnom	12

Applying Calibration Factors

Suppose you obtain a reading of 0.57V from sensor 10001, which has a gauge length of 2 meters. How do you convert the voltage reading to mm of deviation?

Converting Readings in Volts to mm per meter

Apply factors as shown below. C5 through C0 are factors that appear on the sensor calibration record. EL is the sensor reading in volts. The result of the calculation is a value in mm per meter.

$$\text{mm/meter} = C5 \cdot EL^5 + C4 \cdot EL^4 + C3 \cdot EL^3 + C2 \cdot EL^2 + C1 \cdot EL + C0$$

	C Factor	EL Reading	Value
C0	-7.0311		-70311
C1	73.878	0.57	42.11046
C2	-0.22265	0.572	-0.07234
C3	-0.33079	0.573	-0.06126
C4	0.19426	0.574	0.002051
C5	0.020221	0.575	0.001217
mm per meter deviation =			34.94903

Calculating Deviation

To calculate deviation for a particular gauge, multiply the mm/meter value by the gauge length of the sensor. In this example, the gauge length is 2 meters, so the deviation would be 2 x 34.949 mm or about 70 mm.

$$\text{deviation in mm} = \text{mm per meter value} \cdot \text{gauge length of sensor in meters}$$

In this example, the gauge length is 2 meters, so the deviation would be 2 x 34.949 mm or about 70 mm.

Calculating Displacement

Displacement (movement) is the change in deviation. The next page shows the direction of movement associated with negative and positive displacement values.

$$\text{displacement} = \text{deviation}_{\text{current}} - \text{deviation}_{\text{initial}}$$

Direction of Movement for Vertical Sensors

Vertical inclinometer casing is typically installed so that one set of grooves is parallel with the expected direction of movement. Sensors are installed so that their fixed wheels point to the direction of movement.

When the bottom of the casing or the bottom of the sensor are used as reference, positive displacement values indicated movement in the direction of the fixed wheels (normally the expected direction).

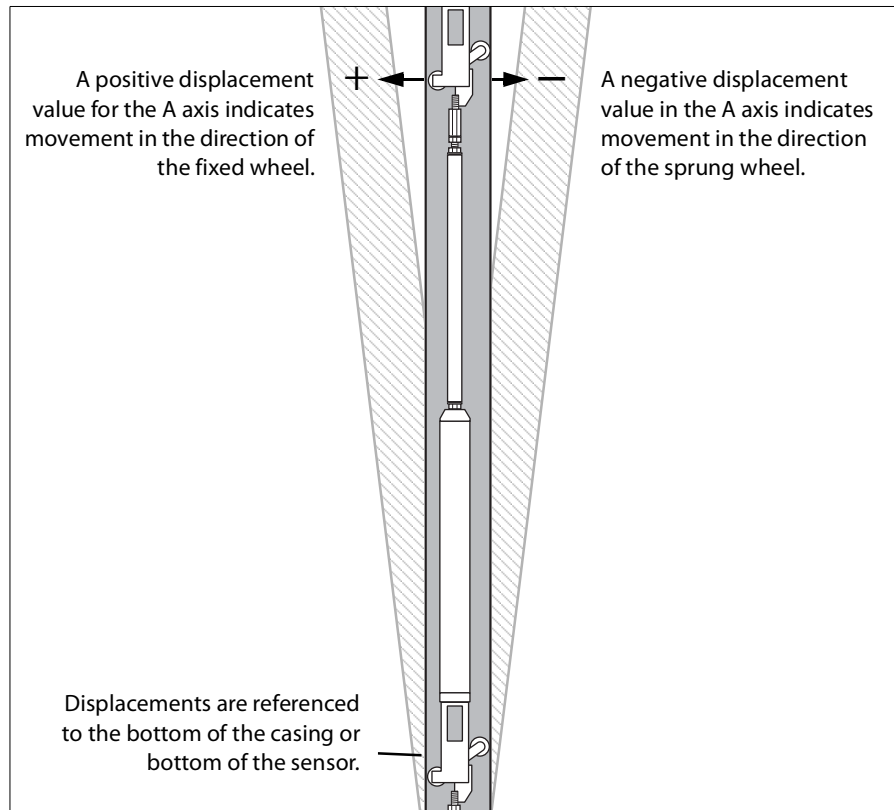

Direction of Movement for Horizontal Sensors

Horizontal inclinometer casing must be installed with one set of grooves oriented to vertical. Sensors are installed with the fixed wheel pointing down.

Far-End Reference

When the far end of the casing or the far end of the sensor is used as the reference, negative displacements indicate upward movement and positive displacements indicated downward movement.

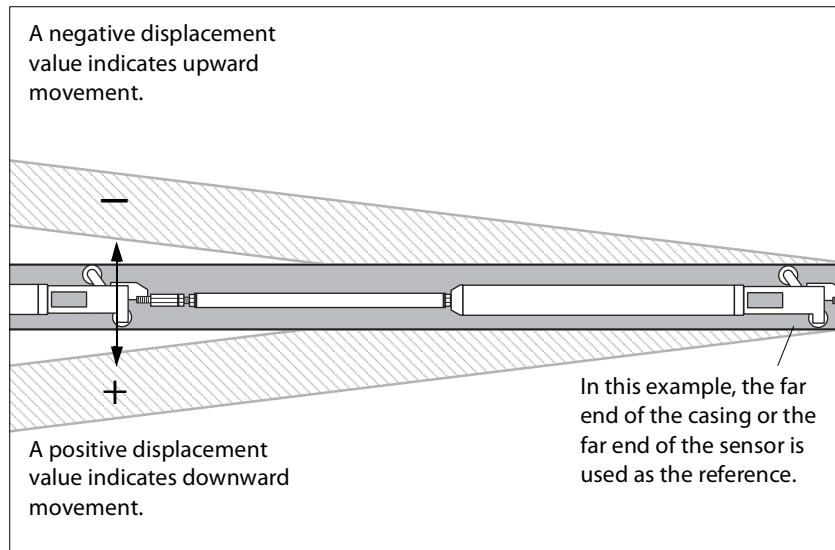

Near-End Reference

When the near end of the casing or the near end of the sensor is used as the reference, negative displacements indicate downward movement and positive displacements indicate upward movements.

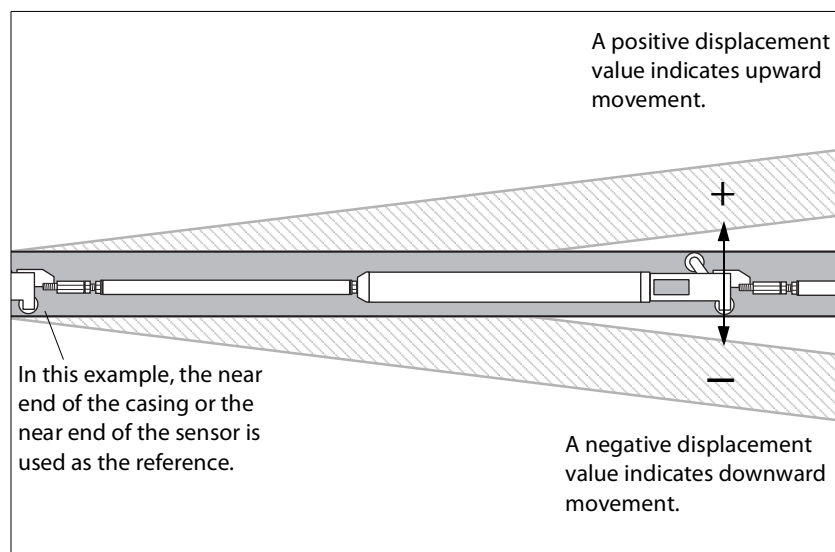

Temperature Readings

The CR10 delivers thermistor readings in volts. The equation below shows how to convert the volt reading to degrees C. The factors in the equation are optimized for temperatures between -15 and 85 degrees C. ET is the volt reading. Toffset is taken from the sensor calibration sheet.

$$\text{DegC} = (9.3219 \times \text{ET}^5) + (-54.3038 \times \text{ET}^4) + (131.165 \times \text{ET}^3) + (-161.2568 \times \text{ET}^2) + (137.7711 \times \text{ET}) + (-37.7705) - \text{Toffset}$$

Temperature Corrections

If the temperature of the sensors remains relatively constant, as is the case for most underground applications, temperature corrections may not be useful. However, if the sensors experience wide variations in temperatures, temperature corrections may be necessary. There are two corrections: a sensitivity correction called SENSTC and an offset correction OFFSTC.

1. Find the change in temperature from Tnom, which is a value on the sensor calibration sheet.

$$\text{DeltaT} = \text{DegC} - \text{Tnom}$$

Example: DegC is 19.3 and Tnom is 12 degrees C, so DeltaT, the change in temperature, is 7.3 degrees C

2. Calculate the sensitivity correction:

$$\text{SENSTC} = \text{S2} \cdot \text{DeltaT}^2 + \text{S1} \cdot \text{DeltaT} + \text{S0}$$

	S Factor	DeltaT	Value
S0	1		1
S1	0.00059828	7.3	0.004367
S2	0.0000068117	7.3 ²	0.000363
SENSTC =			1.00473

3. Calculate the offset correction:

$$\text{OFFSTC} = \text{F2} \cdot \text{DeltaT}^2 + \text{F1} \cdot \text{DeltaT} + \text{F0}$$

	F Factor	DeltaT	Value
F0	0.00012125		.000121
F1	0.016273	7.3	0.118793
F2	0.00096919	7.3 ²	0.051648
OFFSTC =			0.170562

4. Apply the corrections:

$$\begin{aligned} \text{corrected value} &= (\text{mm/meter value} \cdot \text{SENSTC}) + \text{OFFSTC} \\ &= (34.94903 \cdot 1.00473) + 0.170562 \\ &= 35.28491 \end{aligned}$$

Removing Sensors

Removal of Sensors

If it is necessary to remove sensors, take the following precautions:

- Never try to remove the assembled string of sensors. The weight and leverage of long gauge lengths make it very easy to damage the wheels.
- You must disassemble the string as you withdraw it, so that you actually remove sensors one by one. When removing each sensor, always clamp the gauge tubing of the downhole sensor to prevent it from twisting.