

# Digitilt DataMate II

50310999

Copyright ©2007 Durham GeoSlope Indicator. All Rights Reserved.

This equipment should be installed, maintained, and operated by technically qualified personnel. Any errors or omissions in data, or the interpretation of data, are not the responsibility of Durham Geo Slope Indicator. The information herein is subject to change without notification.

This document contains information that is proprietary to Durham Geo Slope Indicator and is subject to return upon request. It is transmitted for the sole purpose of aiding the transaction of business between Durham Geo Slope Indicator and the recipient. All information, data, designs, and drawings contained herein are proprietary to and the property of Durham Geo Slope Indicator, and may not be reproduced or copied in any form, by photocopy or any other means, including disclosure to outside parties, directly or indirectly, without permission in writing from Durham Geo Slope Indicator.



12123 Harbour Reach Drive  
Mukilteo, Washington, USA, 98275  
Tel: 425-493-6200 Fax: 425-493-6250  
E-mail: [solutions@slope.com](mailto:solutions@slope.com)  
Website: [www.slopeindicator.com](http://www.slopeindicator.com)

---

# Contents

Digitilt DataMate II.....	1
Setting Up Installations .....	4
Recording Surveys.....	6
Retrieving Surveys.....	10
Validating Surveys .....	11
Comparing Surveys.....	14
Inspection and Maintenance .....	15
Trouble-Shooting.....	17

# Digitilt DataMate II

## What is the DataMate II?

The Digitilt DataMate II is a recording readout used with the Digitilt inclinometer probes, the portable Digitilt tiltmeter, and the spiral sensor. It works with both metric and English-unit versions of these sensors.

The Digitilt DataMate records readings from inclinometer surveys. DMM software is used to transfer the recorded readings to a PC. The use of DMM software is covered by a separate manual: DMM for Windows.

## DataMate Controls



### Power Switch

The power switch locks into position. To switch on, pull the lever up, then move it to the On position. To switch off, pull the lever up, and then move it to the off position. The DataMate displays a copyright notice for ten seconds when you switch it on. The copyright date serves as the version number for the DataMate.

### Connector Sockets

**Probe:** Socket for inclinometer control cable.

**Charger:** Socket for battery charger or external power.

**USB:** Socket for computer interface cable and remote hand switch.

Sockets are waterproof only when connectors are plugged in or when protective caps are in place.

### Keypad

**Up:** Moves cursor up. Also scrolls forward through the alphabet (a...z).

**Down:** Moves cursor down. Also scrolls backwards through the alphabet (z...a).

**Left:** Moves cursor to the left.

**Right:** Moves cursor to the right.

**Esc:** Cancels current process and returns to menu.

**Enter:** Chooses menu items. In record mode, records readings.

---

## DataMate Menus

1. Use the arrow keys to select a menu item with the cursor.
2. Press Enter to choose the item or Esc to exit the item.

### Main Menu

The Main menu appears when you turn on the DataMate. The Main menu shows the main functions of the DataMate.

Read	Surveys
Comm	Utilities

### Read Menu

The Read menu lets you record inclinometer readings, edit inclinometer installation parameters, review and correct readings, and operate the readout in manual mode, which displays readings but does not record them.

Record	Installation
Correct	Manual Read

### Surveys Menu

The Surveys menu lets you list the surveys that are stored in memory, validate a survey, check available memory, delete a survey, compare one survey to another, and print a survey to a terminal program.

Dir	Validate	Memory
Del	Compare	Print

### Comm Menu

Comm puts the DataMate into communications mode for transferring data to and from a computer. Communications requires that the DataMate II is connected to the computer's USB port via the interface cable that is supplied with the DataMate.

Waiting for PC...
-------------------

### Utilities Menu

The Utilities menu lets you set defaults, and check battery voltage and memory.

Batt	Beep	Light
Temp	Date	Contrast

---

## Setting Defaults

Go to the Utilities menu to set the defaults below:

**Date and Time:** Choose Date. The DataMate displays the current date and time. Press Enter to edit the date. Press Up or Down to change the year, then press Right to move the cursor to month, etc. Press Enter when done.

**Beeper:** Choose Beep. Press Enter to toggle the beeper on or off. The beeper produces a noise when you record a reading.

**Backlight:** Choose Light to toggle the backlight on and off. Backlight increases battery drain by about 12 percent.

**LCD Contrast:** Choose Contrast. Press Up or Down to adjust contrast for easy viewing. Press Esc when done.

## Checking the Battery

Go to the Utilities menu. Choose Batt. A new, fully charged battery shows approximately 6.6 volts with a full charge. Recharge if below 6 volts.

## Recharging the Battery

Recharge the battery after every use of the DataMate. It is best to charge overnight.

Plug the charger into an AC mains socket. Plug the Lemo connector into the DataMate's Charger socket. You can verify that charging is taking place by going to the Utilities menu and choosing Batt. You should see increasing voltage value.

## Checking Memory

Go to the Surveys menu. Choose Memory. The DataMate displays how many depths and surveys are free (available to store data). The maximum numbers are 32000 depths and 320 surveys.

## Moisture Management

When you return to the office, remove caps from the DataMate's connectors and allow connectors to air-dry for a number of hours.

Use desiccant to keep the inside dry. This is particularly important in hot humid weather. Warm moist air trapped in the readout can condense when the readout is brought into a cool air-conditioned office.

To check the moisture level in the DataMate, go to the Utilities menu and choose Temp. The DataMate displays humidity and temperature. Humidity levels from 20% to 60% are normal. If humidity exceeds 75%, replace the desiccant. See instructions in the chapter on inspection and maintenance.

---

# Set Up

**Overview**      Setting up the DataMate involves entering a list of inclinometer installations into the DataMate's memory. You can do this with DMM software or with the DataMate's keypad.

**Setting Up with DMM Software**      This method is convenient when you are in the office:

1. Use DMM to create a setup database on your PC.
2. Connect the DataMate to your PC.
3. Use DMM to transfer the setup to the DataMate.

**Setting Up with DataMate Keypad**      This method is convenient when you are in the field.

1. Choose Read.
2. Choose Installation.
3. Press Down key to scroll past any previously entered installations. The cursor stops on the word, "Create." Press Enter.

4. Enter the required information into each field. The fields are explained on the next page. To make an entry:

Press the Right key to enter edit mode.

Press the Up or Down key to change the character under the cursor.

Press the Right key to move to the next column.

Press Enter when you are done. The DataMate exits edit mode and moves the cursor to the next line.

5. To correct a mistake, press the Up or Down key to display the line that you want to correct. Then press the Right key to enter edit mode.

---

## Installation Fields

**Site & Installation:** Every installation has a two-part identifier consisting of a “site” and an “installation.” Enter a 6 character identifier for each.

**A0 dir:** (Optional) Enter up to 3 characters to identify the compass heading of the A grooves. Not used for any calculation.

**Operator:** (Optional) Enter up to 3 characters to identify the operator. Optional.

**Sensor#:** Enter the serial number of the probe. Optional, but recommended.

**Sens Type:** Choose Digitilt for inclinometer probes or Spiral for spiral sensors.

**Units:** Choose Metric or English. If you don’t know, check the distance between the upper and lower wheels of the probe: 0.5 m for metric systems; 2 feet for English-unit systems.

**Ins Constant:** Use 25000 for metric-unit systems or 20000 for English-unit systems.

**Start:** Enter the starting depth for the survey. Surveys typically start at the bottom of the casing. With English-systems, it is best to use an even number so that 2-foot intervals coincide with cable markings.

**End:** Enter the ending depth for the survey, typically 0.5 for metric-unit systems or 2 for English-unit systems.

**Interval:** Interval is typically 0.5 for metric-unit systems and 2 for English unit systems. For a Spiral Sensor, set the interval to 1.5 meters or 5 feet.

## Check the Installations

Verify that the DataMate now holds your installation list:

1. Choose Read from the main menu.
2. Choose Installation.
3. Scroll through the list of installations.

---

# Recording Surveys

## Good Practices

1. Use the same probe and control cable for each survey, if possible.
2. Use a pulley assembly, if possible. It prevents damage to the control cable.
3. Use a consistent top reference. The goal is repeatable placement of the probe within 5 mm or 1/4 inch. If one technician uses a pulley and another technician does not, probe positioning will be inconsistent, and data will be unusable.
4. Connect the probe to the DataMate and switch the power on before you insert the probe into the casing. Powered-up sensors resist shock better than unpowered sensors.
5. Wait 10 minutes for the probe to adjust to the temperature of the borehole. This helps prevent bias-shift (offset) errors.
6. Always pull the probe upward to the reading depth. If you accidentally pull the probe past the intended depth, lower it to the previous depth, then pull it back up to the intended depth. This ensures consistent placement.
7. Wait for displayed readings to stabilize. The DataMate displays 3 diamonds when readings have stabilized within two units. If the reading does not stabilize, watch the display and try to record an average reading.
8. When you remove the probe from the casing, use your hand to compress the wheels so that they don't spring free or force the body of the probe to strike the side of the casing. This helps prevent bias-shift errors.
9. Check your readings using the DataMate's Validate command. If necessary, reposition the probe at the required depth and use the Correct command to obtain a new reading for that depth. The Correct command is explained later.
10. If you accidentally turn off the DataMate during a survey, turn it back on, and then use the Correct command resume the survey. There is no need to start a new survey.

## Recording a Survey

1. Connect the control cable to the probe. Do not over-tighten. Plug the other end of the control cable into the Probe socket on the DataMate. Plug the handswitch into the USB socket.
2. Insert the probe into the casing with upper wheels in the A0 direction. Lower the probe to slightly below the start depth.
3. Switch on the DataMate and wait for the main menu. Choose Read.

Read	Surveys
Comm	Utilities

4. Choose Record.

Record	Installation
Correct	Manual Read

5. Choose an installation from the list.

Select Installation
SR18 IN1

6. Press Enter to step past the installation parameters without making changes. Normally, no editing is required.

Edit Installation
Site :SR18 IN1

Press Enter or Down to step past each parameters

7. Finally, the DataMate displays the Start depth (bottom depth).

Start depth

50.0 ♦	204	48
Depth	A0	B0

8. Wait ten minutes for the probe to adjust to the temperature at the bottom. This step is important for consistent readings.
9. Begin the survey. Raise the probe to the start depth, then watch for a stable reading. You will see three diamonds, as shown below. Press Enter to record the reading.

50.0 ♦	206 ♦	52 ♦
Depth	A0	B0

Three diamonds ♦♦♦ indicate stable reading. Press Enter to record.

Recording a Survey continued

10. The DataMate beeps and scrolls to the next depth. The reading just recorded is now on the bottom line. Raise the probe to the next depth (shown in the top line of the display) and wait for the numbers to stabilize. Press Enter to record the reading.

After you record the reading, pull the probe up to the next depth.

48.0 ♦	210	55
50.0*	206*	52*

Recorded readings are marked with a \*

11. Repeat this process until you have recorded the reading for the top depth. The DataMate displays a menu. Choose Continue.

Continue	0
Done	Del

12. The DataMate now displays the starting depth for the second pass. Remove the probe from the casing and rotate it 180 degrees so that the upper wheels point to the A180 direction. Insert the probe and lower to the bottom of the casing, or slightly below the start depth.

50.0 ♦	-210	-60
Depth	A180	B180

13. Pull the probe up to the start depth. Wait for the numbers to stabilize. Press Enter to record.

48.0 ♦	-215	-75
50.0π	-210π	-60π

Recorded readings for the second pass are marked with the Pi symbol.

14. Repeat these steps until you have recorded the reading for the top depth. A menu appears. This time, choose Done. Then remove the probe from the casing.

Continue	0
Done	Del

15. You may want to validate the survey using the DataMate's validate command. See Appendix 1 for instructions.

- 
- Making Corrections**     If you make a mistake during the survey, you can easily correct it.
1. Use the Down key to return to the depth where the mistake was made. Stop scrolling when the depth appears in the top line of the display.
  2. Now position the probe to that depth: lower it below the depth and then pull it upwards to the exact depth.
  3. Press Enter to activate the top line of the display. A diamond appears next to the depth.
  4. Wait for the readings to stabilize, then press Enter to record.
  5. Continue recording just as you would in a normal survey. Or if you are finished, scroll to the top depth and complete the survey as you normally would.
- Cancelling a Survey**     1. Press Esc. If you press Esc by mistake, press Continue.
2. Choose Del to delete the survey that you cancelled. Cancelled surveys remain in memory until deleted.
  3. The DataMate prompts for confirmation. Press Up to confirm.
- Deleting a Survey**     If you want to record a survey, but the DataMate prompts “no room in memory” or “too many surveys,” you must free some memory by deleting a survey.
1. Choose Surveys from the main menu.
  2. Choose Del.
  3. Select a survey to delete and press Enter. (Surveys marked with the ^ symbol have been retrieved by a PC, so it might be safe to delete one of them.)
  4. Press Up to confirm the deletion or Esc to cancel. The DataMate deletes the survey. To avoid possible loss of data, do not switch the DataMate off during this process.
- Deleting an Installation**     The DataMate itself provides no way to delete installations. DMM is required for deleting installations.

---

# Retrieving Surveys

- Overview** To retrieve surveys, connect your DataMate to your PC and run the DMM program. This is the normal and most efficient way to retrieve data.
- Using DMM** Detailed instructions are provided in the DMM manual. The basic steps are:
1. Connect the DataMate to your PC. Choose Comm on the DataMate.
  2. Start DMM, go to Datamate in the menu, and choose either Retrieve New or Retrieve all.
  3. Drag and drop the retrieved surveys into your project database (or export surveys to a text file).
- Using a Terminal Program** You can “print” surveys, one by one, to a PC that is running a terminal program on your PC to receive it. This is mainly for troubleshooting. The DMM program can import print files.
1. Connect the DataMate to the PC.
  2. Start your terminal program. Set it for 8-bit, no parity at 9600 bps.
  3. Set the terminal program to “capture” or “log” the data sent from the DataMate. Specify a file name for the captured data.
  4. Choose Print from the DataMate survey menu. Set the baud rate for 9600 and press Enter. Then select the survey and press Enter to “print” it.
  5. Your terminal program will usually display the readings as they are sent from the DataMate.
  6. Close the file with your terminal program.

---

# Validating Surveys

## About Checksums

A checksum is the sum of 0 and 180 degree readings at the same depth. Ideally, the sum should be zero since the readings have opposite signs. In practice, checksums are rarely zero.

In general, you should look for consistency in checksums. A checksum that is significantly different from checksums above and below it may indicate that the probe wasn't positioned correctly or the reading was not stable when recorded. A large checksum may also be caused by debris in the groove, an out-of-round casing section, a separated casing section, or a wheel falling in the joint of a telescoping casing section.

A graph of checksums shows very clearly whether checksums are consistent or not. Alternatively, scanning through a column of checksums gives you an idea of consistency. Unfortunately, the DataMate provides neither graphs nor columns of checksums. However, the DataMate does provide the standard deviation of checksums, which can be used as a measure of reading quality, as explained below.

## Standard Deviation of Checksums

The standard deviation of checksums can be used as a way to confirm that the current survey is comparable to other surveys for the same borehole.

You must first establish a "typical SD" for each axis. This is obtained from your initial survey. (It is good practice to take several surveys initially, then compare them and select one to be the "official" initial.) Since the initial survey represents good set of readings, the standard deviation of checksums for that survey can be used as a "typical SD" for that installation. Note that the "typical" is likely to be different for every installation.

When you obtain a new survey, run the DataMate's validation routine. Compare its SD to those of the initial survey. If the typical standard deviation of the A-axis is 3 to 5 units, the data is probably good. For example, if the typical standard deviation is 4, then acceptable standard deviations for subsequent surveys could range as high as 7 or 9 (typical for B-axis).

Narrower limits may be appropriate for deeper installations and critical measurements. Wider limits may be appropriate for shallower installations or for poorly-installed casing.

---

## Validating a survey

Here is a typical validation procedure:

1. Check the standard deviation of checksums. Is it typical for this casing? If so, the survey is probably good and needs no further validation. You can quit the validation routine.
2. If the standard deviation is not typical, check the standard deviation for the different zones. If any group shows an obvious problem, examine the individual checksums in that group. Also look for drifting mean checksums. A drifting mean may indicate a problem with the electronics inside the probe.
3. If you find a checksum that is too large, examine the readings at that depth to determine whether the bad reading was recorded in the 0 or the 180 orientation. Afterwards, you can correct the data by taking another reading for that depth.
4. The steps below explain this in detail.

## Check the Standard Deviation

1. Choose Validate from the Surveys menu.
2. Choose a survey to validate.
3. After a short delay, you will see a display that shows both the mean (MN) checksum and the standard deviation (SD) of checksums:

MN	A=51.337	B=45.674
SD	A=4.1781	B=5.7170

4. Compare the standard deviation with the “typical” SD that you have established for the installation. If the standard deviation is acceptable, press Esc to quit. Otherwise, look at the SD for each zone.

## Check Zone Statistics

1. Press Enter to view the zone with the largest SD. You will see a display that looks something like this:

25. - 20.	S.D.
A=3.2264	B=10.3388

Zone statistics include 10 readings. In this case, there are 10 half-meter readings in the zone from 25m to 20m.

2. To view the mean checksum for this zone, press the Left arrow. Press Right to redisplay the SD.
3. Press Up or Down to display other zones. Again, the Left and Right keys toggle between mean and standard deviation.
4. If you decide the survey is acceptable, press Esc to quit. Otherwise, note the zones (depths) that you want to inspect and continue.

---

## View Individual Checksums

Follow the steps below to find depths with large checksums:

1. After viewing the checksum statistics, press Enter to view checksums. The DataMate first displays the largest checksum in the survey. In this case, the 89 in the B axis is largest.

25.	20	89
25.5	25	34

Depths            A            B

2. Use the Up and Down keys to view checksums at other depths. When you are finished viewing checksums, press Esc.

## Isolating the Bad Reading

A large checksum may indicate a bad reading, but does not indicate which reading was bad (Was it the 0 or the 180 reading?). To isolate the bad reading, you must view readings above and below the suspect reading.

1. Choose Read from the main menu.
2. Choose Correct, then choose a survey (If necessary, press Right to see dates).
3. Press the Enter key to skip through parameters.
4. Choose 0 (orientation). Scroll through readings to the suspect depth. Check readings above and below the depth. A bad reading does not fit with the readings above and below it.
5. To view 180 readings at the same depth, press the Right arrow. Press again to display the 0 readings.
6. Note the depth and orientation of the bad reading. Then press Esc.

## Correcting a Reading

1. Choose Correct from the Read menu.
2. Choose 0 or 180, and scroll the DataMate to the required depth. The depth should be displayed on the top line.
3. Lower the probe to the required depth. Wait for the probe to adjust to the temperature in the borehole (5 to 10 minutes if the probe has been in open air)
4. Press Enter to activate the reading. Press Enter again to record the reading.

---

# Comparing Surveys

**Overview** The DataMate can calculate a single value for cumulative deviation or for cumulative displacement.

- Cumulative Deviation**
1. At the Main Menu, select “Surveys.” Then select “Compare.”
  2. The DataMate prompts for the current survey. Press Enter to select the suggested survey or scroll to find a different survey.
  3. The DataMate prompts for a “previous” survey. Press Esc since you do not want to calculate displacement.
  4. The DataMate asks you to confirm a conversion value of 1. Press Enter. This will display metric data in meters and English data in feet.
  5. The DataMate then calculates the cumulative deviation for the survey and displays it.
  6. Press Esc to return to the Surveys menu.

**Note** The DataMate calculates cumulative deviation by summing incremental deviations from the bottom of the casing to the top.

If you are interested in borehole drift, you probably want the top of the borehole to be used as reference. The DataMate does not offer this as a choice, but when summing from the top, the deviation at the bottom of the borehole will be the same value except in the opposite direction.

**Cumulative Displacement** To calculate displacement, the DataMate must contain two surveys for the same installation.

1. Choose Surveys from the main menu, then choose Compare.
2. The DataMate prompts for the current survey. Press Enter to select the suggested survey or scroll to find a different survey. Then the DataMate prompts for a “previous” survey. Scroll to find the initial set, then press Enter.
3. The DataMate prompts for a conversion value. Enter 1000 for a displacement in millimeters (with metric data). Enter 12 for a displacement in inches (with English unit data).
4. The DataMate then calculates the cumulative displacement for the survey and displays it. Press Esc when done.

# Inspection and Maintenance

## Inspection

Part	What to check for	Remedy
Desiccant	Check humidity under utilities menu.	If humidity exceeds 75%, replace or recharge desiccant.
Batteries	Check main battery and Memory keep alive power under utilities menu.	Main battery can be recharged. If battery does not hold charge, battery can be replaced. Lithium backup battery is good for 7 to 10 years if main battery keeps charge. Return for servicing if memory power is bad.
Connectors	Dirt, bent pins, o-ring	Clean with alcohol moistened swab. Note that connectors are "water proof" only when capped or when connector is plugged in.
Self Test	Error A input Error B input	Bad signal input. Return for servicing. A value is displayed, but is not useful.
	Error +12volt Error -12volt	±12V sensor power. Disconnect control cable and probe. Try again. If error goes away, problem could be in probe or cable. Connect cable only. If no error, then probe is the problem. This error could also be caused by discharged battery. Try recharging battery first. If error persists, some component must be returned for servicing.
	Error battery	Main battery is low. Try recharging. If error persists, replace battery.
	Error +3v pwr	Memory keep alive power is bad. Retrieve any data before switching off, then return for service.
	Error temp	Operating temperature range exceeded. Either below -20 or above 60C.
	Error humidity	Humidity above 80%. Replace desiccant.

## Maintenance

Battery	<p>Recharge battery after every use. Charge at least two hours for every hour of use. Charging overnight is common practice. Do not charge longer than 72 hours. Longer charge time may damage the battery. A new, recharged battery will show 6.6V or higher.</p> <p>The DataMate displays a low battery warning when voltage drops to 5.5 volts. Turn off the DataMate when the warning appears and then recharge as soon as possible. Deep discharge of the main battery can reduce its performance and shorten its life.</p>
Desiccant	Check humidity under utilities menu. If humidity exceeds 75%, replace desiccant.
Connector sockets	If it is necessary to clean the connector, use a small brush or a slim cotton swab. Do not use spray lubricants or electric contact cleaners. Solvents contained in such products will attack the neoprene inserts in the connectors.

**Replacing Desiccant**

You must open the DataMate to change the desiccant. You should ground yourself to prevent a static discharge that could damage the DataMate's electronics.

Remove the two screws from the bottom of the case. Hold the top panel and pull off the case. Look for the desiccant pack between the battery and the panel connectors. Replace the desiccant pack with a new one. You may be able to renew the desiccant in an oven at 250 °F (121 °C) for 16 hours. Do not use a microwave oven to renew the desiccant. You may damage your microwave oven.

Before you replace the case, apply a light coat of silicone grease to the gasket. Also lubricate the O-rings on the screws. Then slip the DataMate back into its case, checking that the gasket is seated properly. Replace the screws and tighten to draw the top panel squarely against the case. Do not over-tighten the screws

**Wiring Diagram for USB Interface Cable**

Below is the wiring diagram for the connectors on the USB interface.

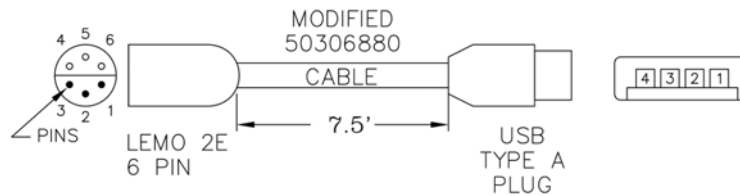
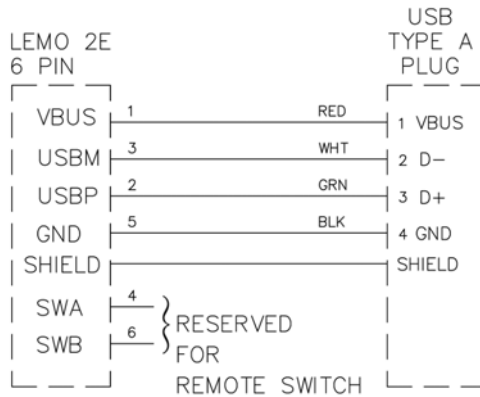

**Wiring Diagram for Hand Switch**

Below is the wiring diagram for the hand switch.

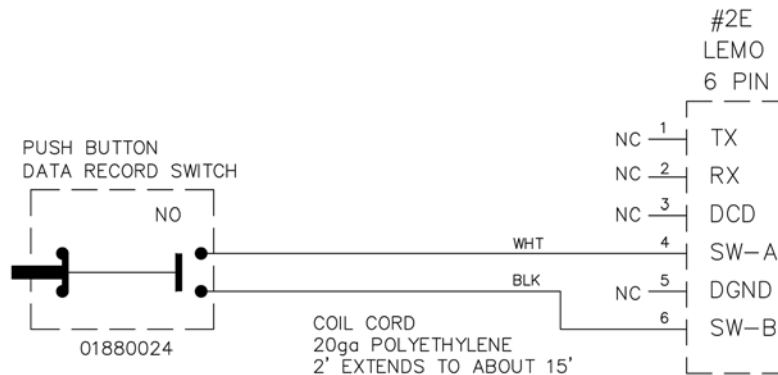

---

# Trouble-Shooting

Tech Notes on  
slopeIndicator.com

Many questions can be answered by a visit to the Tech Notes section of [www.slopeindicator.com](http://www.slopeindicator.com). Go to Support - TechNotes. Then scroll down the page to find the inclinometer tech notes. Take a look at the Digitilt DataMate Q & A page.

Readings Not Stable

The DataMate's ready signal is displayed when readings in both axes are stable within 2 digits. If this happens occasionally, but readings vary within 3 or 4 digits, you can record the readings with no significant loss of accuracy.

- If this problem always occurs at a single installation and at a just a few depths, it is possible that the backfill around the casing has washed away or was simply incomplete.
- In some situations, such as when there is no water in the inclinometer casing, control cable can go into a slow oscillation, shaking the probe, and preventing full stabilization of readings. The same may occur at sites where heavy construction machines are active. In this case, look for the average reading.
- Reading instability can also be caused by a low battery, so always check battery voltage before you leave the office.
- If readings always take a long time to stabilize, and this happens at all installations, contact Slope Indicator.

Strange Readings

**A & B readings are midrange or higher (e.g. +6000 or -6000):** Mid-range readings like this point to a cable problem. It is likely that one of the power wires is bad. The problem may be in a broken or corroded wire in the connector.

**Readings are very high, for example 12,000:** If your DataMate shows a full scale reading, such as 10,000 or 12,500, when the probe is near vertical, there is probably water in the connector or in the cable.

**Reading of +1786 (English) or 3125 (Metric):** This is the same number that the DataMate displays when the probe is not connected, so there is most likely a problem in the cable or a connector.

**Reading of 60 or some other low number:** If you see a low number that stays constant in one axis, the problem is mostly likely in the probe. The accelerometer for that axis is not working and the op amp is trying to compensate, resulting in a constant value.