

Center-Hole Load Cell

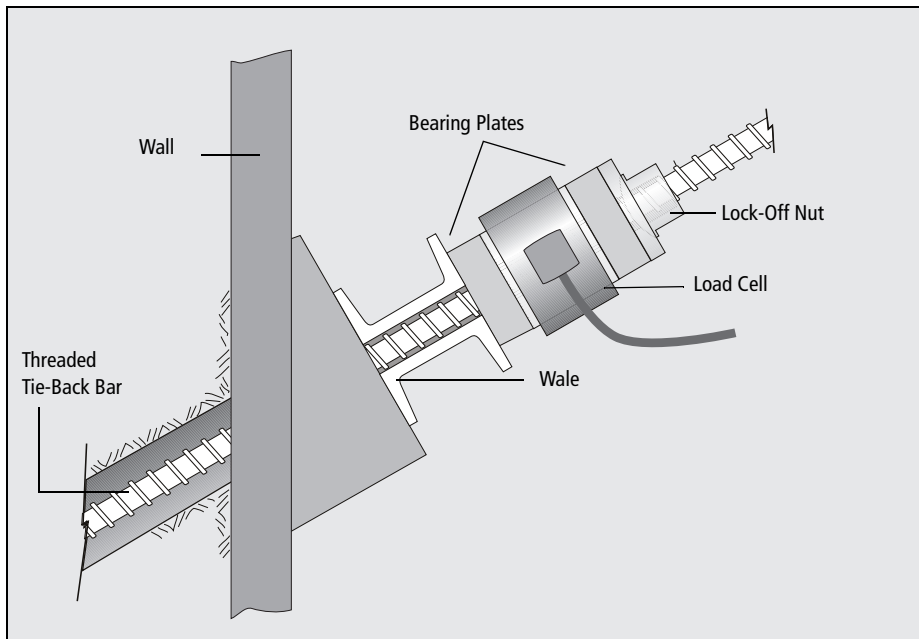

Center-Hole Load Cells



Load Cell installed to monitor tieback

Applications

Center-hole load cells are designed to measure loads in tiebacks, rock bolts, and cables. Applications for these load cells include:

- Proof testing and long-term performance monitoring of tiebacks, rock bolts, and other anchor systems.
- Monitoring loading of vertical supports in underground openings.

Operation

The load-bearing element of the load cell is a spool of heat-treated steel alloy. Four or more strain gauge rosettes are bonded to the spool. Each rosette consists of two strain gauges, one oriented to measure axial strain; the other oriented to measure tangential strain. The rosettes are spaced evenly around the periphery of the spool and are wired together to provide a single output.

The strain gauge rosettes are protected from moisture and impact damage by a strong aluminum housing filled with a high-density resin.

For best results, the load cell is centered on the bar and bearing plates are placed above and below the cell. Bearing plates must be able to distribute the load without bending or yielding.

Advantages

Single Reading: The outputs of the strain gauges are integrated into a single reading, eliminating the switch box, multiple readings, and averaging normally associated with other types of center-hole load cells.

Easy Centering: Centralizers keep the load cell centered on the bar, bolt, or cable.

Manual or Automatic Readout:

Load cells are read manually with a portable readout or automatically with a data logger.

LOAD CELL SPECIFICATIONS

Sensor Type: Resistance strain gauges wired to provide a single output of 2.5mv/v \pm 10%.

Part Numbers, Range, & Dimensions: See table at below.

Linearity: 1% FS.

Overload Capacity: 100%.

Centralizer: Centralizer is used to center load cell on tiebacks or rock bolts. User can adjust inside diameter of centralizer within range listed in table.

Signal Cable: Attached to load cell at factory. Must be ordered at same time as load cell.

SIGNAL CABLE & CONNECTORS

Signal Cable 50613527
Shielded cable with seven 22-gauge tinned-copper conductors and polyurethane jacket. Specify cable length required for each load cell.

Universal Connector 57705001
Connector is not required when load cell is used with data logger.

Universal Terminal Box 57711600
Provides connections for 12 sensors and an indicator. Sensors selected by rotary switch. Weatherproof fiberglass box measures 290 x 345 x 135 mm (11.5 x 13.5 x 5.25"). Not required when load cell is connected to data logger

READOUTS & DATA LOGGERS

CR10X Data Logger 56701110
CR10X can read the centerhole load cell. Up to five load cells can be connected to each AM16/32 multiplexer. See separate data sheet.

DataMate MP 57710900
DataMate MP readout can read center hole load cells. See separate data sheet.

Load Cell Indicator 51300900
Portable indicator for center-hole load cells. Displays, but does not record readings. Includes battery, charger, and jumper cable. Specify plug type needed for charger. Also specify if you are using the universal connector or terminal box, since they require a special jumper.



Displayed Units: Percent of full scale.

Resolution: 0.01% of full scale.

Display: Large, backlit 4.5 digit LCD with heater for cold weather operation.

Selector Switch: Provides switching to eight different sensors when connected to suitably wired signal cable.

Batteries: Rechargeable 6 volt, 6Ah lead-acid battery. Batter life is 12 hours with fully charged battery. LCD heater reduces operating time up to 50% when temperature is below 5°C (40°F).

Environmental Limits: -20 to 50°C. (-4 to 122°F). Splashproof, non-submersible. Connector socket is waterproof when capped or in use.

Dimensions: 127 x 178 x 178 mm (5 x 7 x 7").

Weight: 3.5 kg (7.5 lb).

LOAD CELL PART NUMBERS, RANGE, AND DIMENSIONS

English Unit Specifications					
Load Cell	Capacity US Ton	ID x OD x Height Inches	Bearing Area Inch ²	Centralizer	Centralizer ID, Inch
51301050	50	1.67 x 3.5 x 3.25	1.67	51302117	0.5 to 1.5
51301100	100	1.67 x 3.5 x 3.25	3.33	51302117	0.5 to 1.5
51301152	150	2 x 4.25 x 3.5	5	51302120	0.5 to 1.5
51301153	150	3 x 5 x 4.5	5	51302130	1.0 to 2.5
51301225	200	2.5 x 5 x 4.5	6.67	51302125	1.0 to 2.0
51301235	200	3.5 x 6 x 5.5	6.67	51302135	1.5 to 3
51301330	300	3 x 6 x 4.5	10	51302130	1.0 to 2.5
51301340	300	4 x 6.63 x 6	10	51302140	1.5 to 3.5

Metric Equivalent of Specifications Above					
Load Cell	Capacity Metric Ton	ID x OD x Height mm	Bearing Area mm ²	Centralizer	Centralizer ID mm
51301050	45	42 x 89 x 83	1077	51302117	13 to 38
51301100	90	42 x 89 x 83	2148	51302117	13 to 38
51301152	135	51 x 108 x 89	3225	51302120	13 to 38
51301153	135	76 x 127 x 114	3225	51302130	26 to 64
51301225	180	64 x 127 x 114	4303	51302125	26 to 51
51301235	180	89 x 152 x 140	4303	51302135	38 to 76
51301330	270	76 x 152 x 114	6451	51302130	26 to 64
51301340	270	102 x 168 x 152	6451	51302140	38 to 89

Conversion Table	lb	kips	US Ton	kg	Metric Ton
lb	1	0.001	0.0005	0.4535	0.0045
kips	1000	1	0.5	453.5	0.4535
US Ton	2000	2	1	907.2	0.9072
kg	2.205	0.0022	0.0011	1	0.001
Metric Ton	2204	2.205	0.907	1000	1

Directions: Choose starting unit at left. Multipliers in same row yield unit at top.

Durham Geo Slope Indicator, 12123 Harbour Reach Drive, Mukilteo, WA, 98275 USA
Tel: 425-493-6200 Tel: 866-916-0541 Email: solutions@slope.com

